



# 丞基技研股份有限公司

## User Manual

**Model : 24V 24W 512 Digital Power Supply-1CH**

**Model P/N : GLC-PD24V24W-1CH**

丞基技研股份有限公司 3AMechatronic Co., LTD.

ADD: 7F-7, No. 12, Lane 609, Sec. 5, Chongxin Rd.,  
Sanchong Dist., New Taipei City 241, Taiwan (R.O.C)

TEL: +886-2-29997331 FAX: +886-2-22787113

# GLC-PD24V24W-1CH USER MANUAL

## I. Product Specifications

### i. Dimensions:

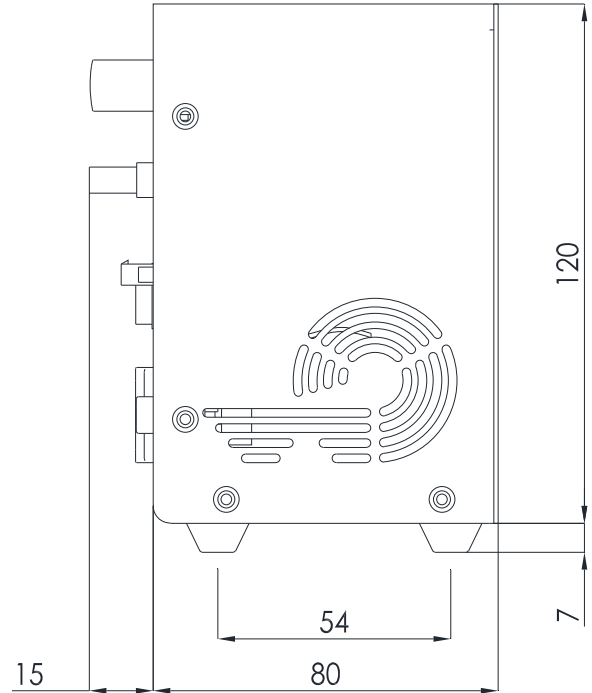
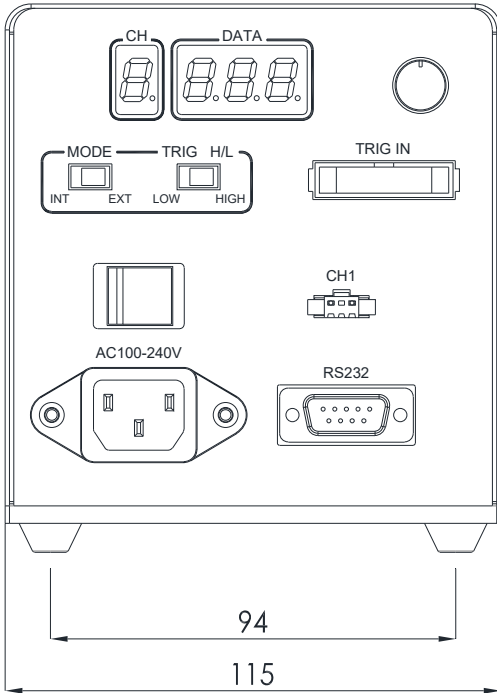

UNIT: mm

### ii. Specifications Chart:

Model	GLC-PD24V24W-1CH	
Mains Voltage	100-240 VAC	
Mains Frequency	50/60 Hz	
Maximum Output Voltage	24 VDC	
Maximum Output Power	24W	
Control Method	Manual, External On/Off Control, RS232	
Dimensions (Width*Depth*Height mm)	120*115*80 (excluding the projection)	
Output Connector Definition		PIN 1: OUTPUT + PIN 3: OUTPUT -

## II. Definitions of Dip Switch and External Trigger



1. MODE: Select modes.

INT: Control manually by knob. EXT: Control by RS232

2. TRIG H/L: Set trigger logic. (If there is no need to trigger externally, switch to LOW.)

LOW: negative logic. Dimmer is outputted if there is no external signal or LOW signal is connected. Dimmer is not outputted when it is connected with HIGH signal.

High: positive signal. Dimmer is not outputted if there is no external signal or LOW signal is connected. Dimmer is outputted when it is connected with HIGH signal.

3. TRIG IN Definition

	PIN	1	2
	Def.	CH1 trigger	DC 0V
Trigger input range : DC 0~24V      LOW: 0~ 0.7V      High: 3.3V~24V			

## III. Definitions of Manual and External Control

1. Manual Control by Knob

Set of Dip Switches

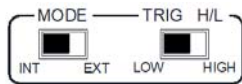

Press knob and switch panel to display the channel to control. Turn the knob to change the output segment.

2. RS232 Control

Set of Dip Switches



A. PIN definition:

PIN NO.	Definition
2	Transmitted Data
3	Received Data
5	Signal Ground

B. RS232 Communications specifications:

Baud Rate: 115200

Byte Size: 8 bits

Parity: None

Stop Bit: 1 stop bit

C. Register Address Description:

Register Address	Description	Value Range
0x0001	Control Value for Ch1	0x0000 to 0x01FF

D. Protocol:

Modbus Protocol format (ASCII only)

a. Single Register Write Command:

Fill in the Register Address and Register Value in write command to modify output value.

Example: To set Ch1 output level 0x01AB.

	Header (1 char)	Additional Address (2 char)	Function (2 char)	Register Address (4 char)	Register Value (4 char)	Check (LRC) (2 char)	Trailer (2 char)
<b>Send form PC</b>	:	0 1 <sub>(fixed)</sub>	0 6	<b>0 0 0 1</b>	<b>0 1 A B</b>	4 C	CR LF
<b>Reply from Device</b>	:	0 1	0 6	0 0 0 1	0 1 A B	4 C	CR LF

Note1: The LRC calculation is to sum up the accumulation of data. (Don't carry. Fetch 8 bits only.) And fetch two's complement. The LRC calculation for the example above is:  $0xFF - (0x01 + 0x06 + 0x00 + 0x01 + 0x01 + 0xAB) + 0x01 = 0x4C$ .

Note2: Start sign ":" is coded 0x3A.

Note3: End signs CR (Carriage Return) an LF (Line Feed) are control characters, and coded 0x0D and 0x0A respectively.

b. Read Command:

Fill in the Starting Register Address and No. of Register to read several consecutive data.

Example: Read the value of output level, and assuming that is 0x0080.

	Header	Additional Address	Function	Starting Register Address	No. of Register	Check (LRC)	Trailer
<b>Send form PC</b>	:	0 1 <sub>(fixed)</sub>	0 3	<b>0 0 0 1</b>	<b>0 0 0 1</b>	F A	CR LF
	Header	Additional Address	Function	Byte Count of Data	Data	Check (LRC)	Trailer
<b>Reply from Device</b>	:	0 1	0 3	0 2	0 0 8 0	7 A	CR LF

Note1: Byte Count of Data is the quantity of reply data from device. Because every Register Value saves 2Bytes data, Byte Count of Data is two times as much as No. of Register.