

FEATURES

- Flexible Platform
 - Smart Camera Platform
 - Production Ready Board-Set
 - Sensor Evaluation Kit
- High-performance sCMOS sensors from Fairchild Imaging (Div. of BAE)
 - Sensitivity: 55% QE @ 600 nm
 - Wide dynamic range: 15,000:1
 - Low noise: < 2 e⁻
 - High speed: 70 fps
 - 5.5M Pixel: 2560(H) x 2160(V)
 - Monochrome / Color
 - Rolling / Global Shutter
- Altera Cyclone V SoC standard processing includes:
 - 1x1, 2x2, 4x4, and 8x8 binning
 - Noise reduction
- Can be customized for application

Interface Options

 - Camera Link
 - Gigabit Ethernet
 - USB 2.0
- Programmable General Purpose I/O
 - 4 External GPIO Pins Available
 - Support trigger input or drive as expose / frame strobes



Figure 1: MityCAM-B2521F (Camera Body)

APPLICATIONS

- Low-light Imaging
- Machine Vision
- Embedded Instrumentation
- Scientific Imaging
- Surveillance Imaging

DESCRIPTION

The MityCAM Vision Solution from Critical Link features a high performance sCMOS image sensor from Fairchild Imaging (a division of BAE Systems). The kit is available with a 5.5MP CIS-2521F sensor, USB 2.0 interface and your choice of either Dual Camera Link or Gigabit Ethernet interfaces.

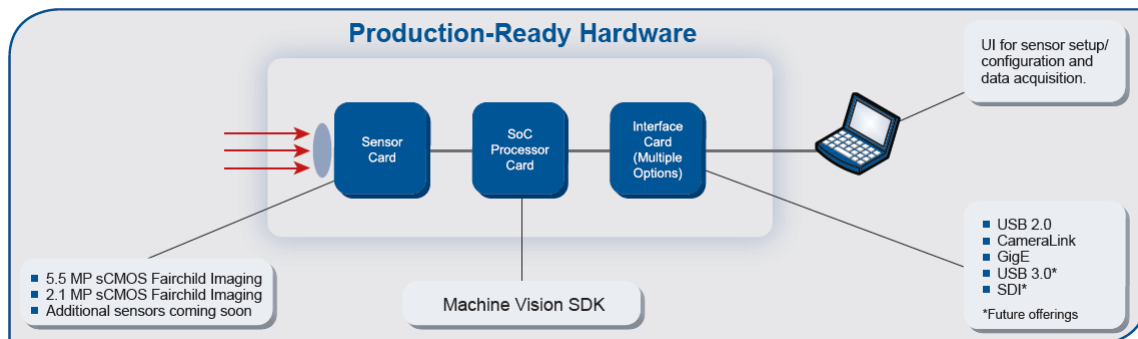

MityCAM is a trademark of Critical Link, LLC.

Combined with Critical Link's Machine Vision SDK software tools design for our Altera Cyclone V SoC based processor card, the MityCAM makes sensor evaluation and integration quick and easy. The enclosed body model features a standard C mount, while the board set version allows quick and easy custom integration into your product with our production-ready hardware.

Detailed datasheets regarding the sensor performance curves for sensitivity, well depth, quantum efficiency and dark current, etc. may be located on the manufacturer's website [1] and within the CIS-2521F datasheet [2].

The block diagram in Figure 2 shows the structure of the MityCAM-B2521F.

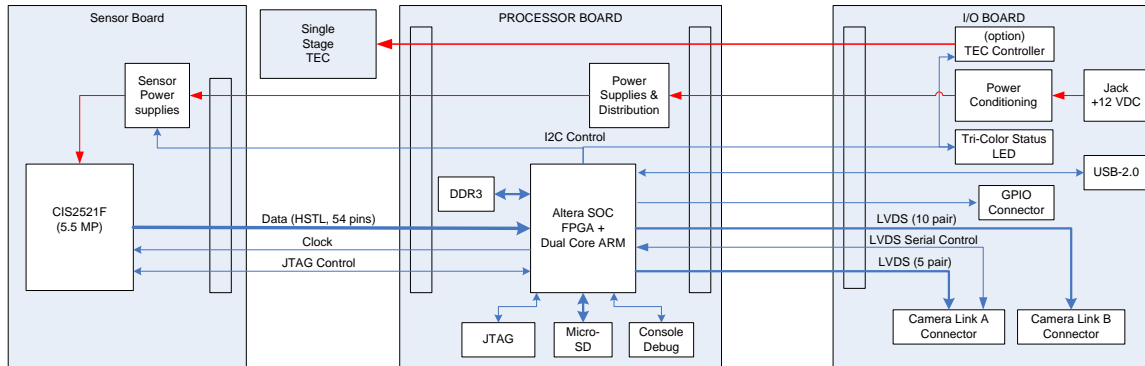

Figure 2: MityCAM-B2521F System Diagram

TECHNICAL SPECIFICATIONS

A summary of the imaging performance of the MityCAM-B2512F family is included below.

PERFORMANCE

	Min	Typical	Max	Units
Active Pixels (CIS-2521F)	-	2560 x 2160	-	H x V
Pixel Size	-	6.5 x 6.5	-	W x H ; μm
Imaging Area (CIS-2521F)	-	16.8 x 14.2	-	W x H ; mm
Dark current @ 20C	-	< 35	-	e ⁻ /pixel/sec
ADC resolution (low gain: 1X)	-	11	-	bits
(high gain: 30X)	-	11	-	
(combined gain: 30X)	-	16	-	
Read-out Noise (@30 fps rolling shutter)	-	< 2	-	e ⁻
Peak Quantum efficiency @ 600nm	-	> 55%	-	%
Dynamic Range	-	15,000:1	-	
Full Well Capacity	30,000	-	-	e ⁻
Cooling Method		Forced Air / Single Stage TEC		
Full Frame Rate (Rolling Shutter)	-	-	70*	Frames / s
Full Frame Rate (Global Shutter)	-	-	35*	Frames / s
Power Utilization (with TEC enabled)	-	13.5	15	Watts
Camera Body Weight		524 (18.5)		g (oz.)
Power Input (12 V +/- 10%)	10.8	12	13.2	V DC

*data rates up to 100 / 50 fps (rolling / shutter mode) are possible but not yet qualified

Table 1: MityCAM-B2521F Performance

QUANTUM EFFICIENCY

A typical monochromatic QE curve is shown below in Figure 3.

Quantum Efficiency of CIS2521 Monochromatic Sensor with Sealed Window on

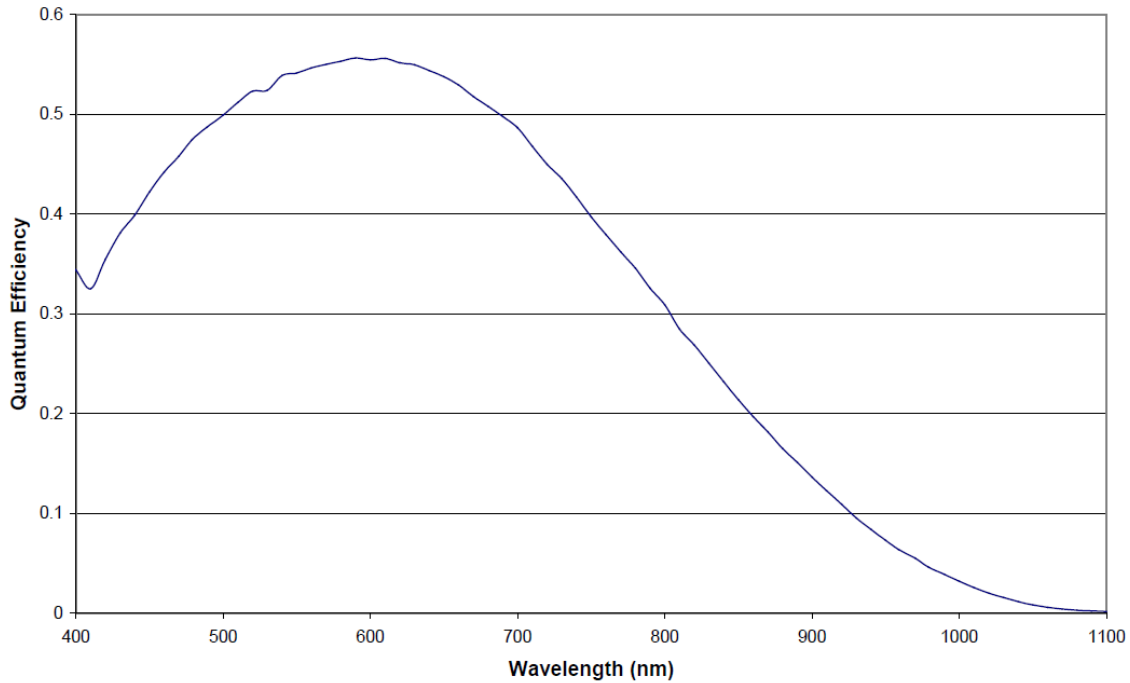

Figure 3: Spectral Response for a CIS2521F Monochromatic Sensor [1]

OPERATING AND STORAGE CONDITIONS

Ambient Operating Temperature Range	0 °C to 50 °C
Humidity	< 80%, Non-Condensing
Storage Temperature Range	-40 °C to 85 °C

Table 2: MityCAM-B2521F Operating and Storage Conditions

ELECTRICAL CONNECTIONS

The MityCAM-B2521F has the following electrical connections on the back panel:

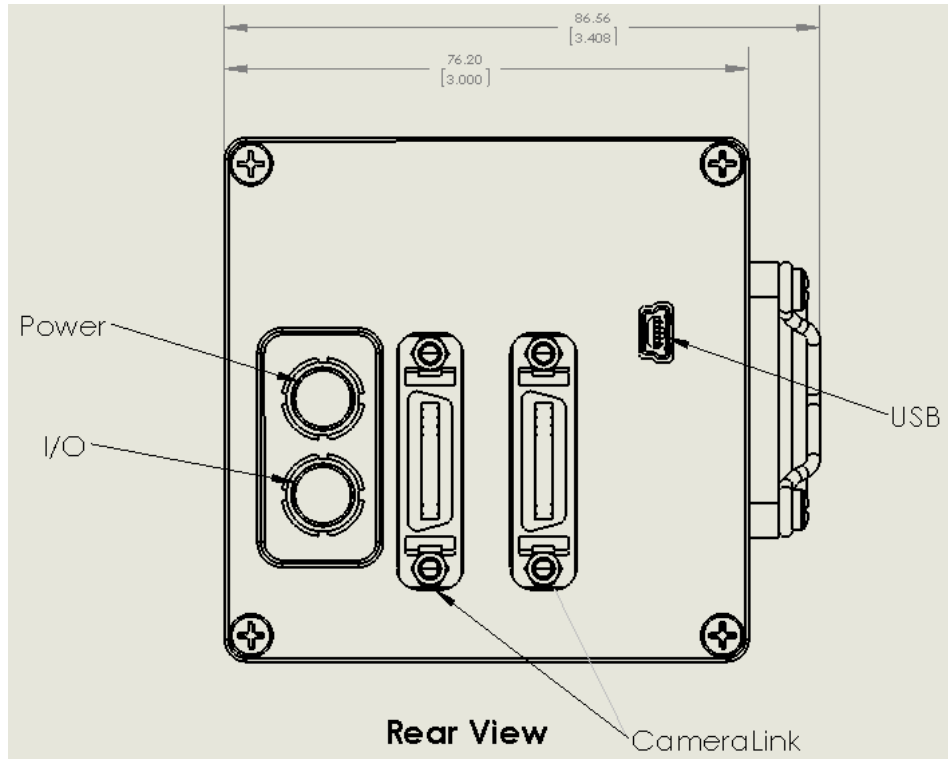

Figure 4: Input / Output Connections on Rear – Dual Camera Link version

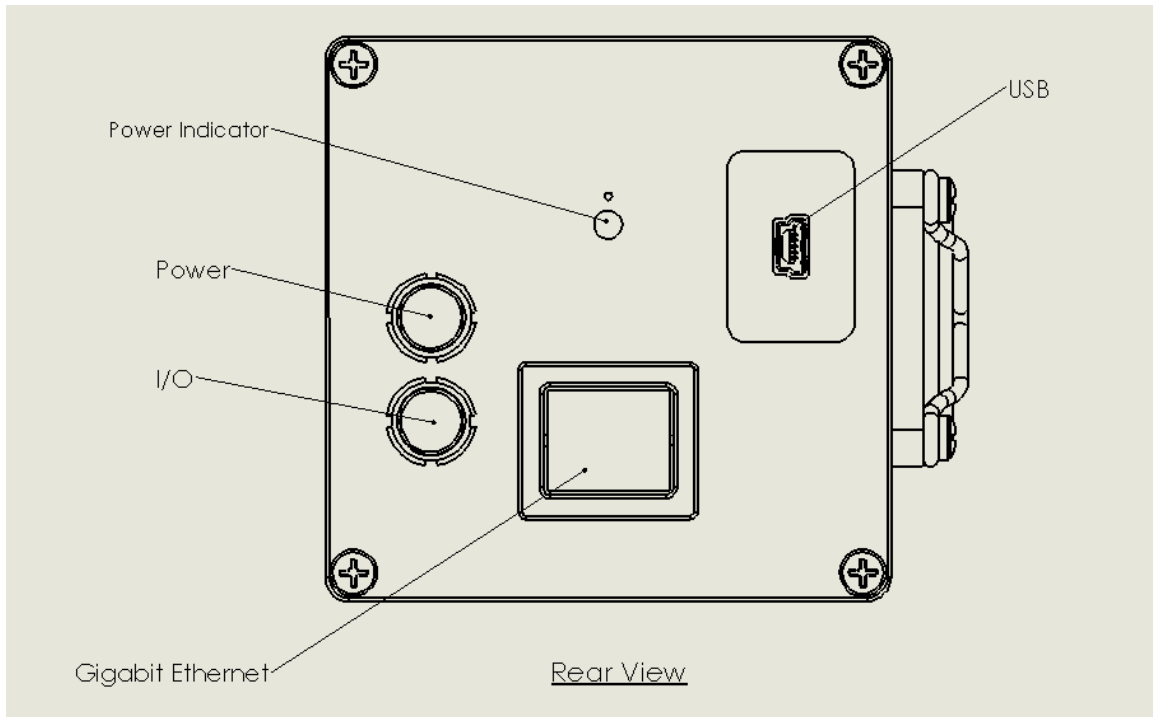

Figure 5: Input / Output Connections on Rear – Gigabit Ethernet version

High-Speed Interface Options

The MityCAM is offered with a number of high-speed interface options.

Dual Camera Link (J201 and J202) – 10-Tap Mode

The MityCAM-B2521F provides a dual Camera Link I/O adaptor that supports expanded 10-tap mode using an 85 MHz clock to output pixel depths of 8 bits (10 pixels per clock), 16 bits (5 pixels per clock), and 12 bits (6.6 pixels per clock) for full resolution images (2560x2160). Expanded 10-tap mode requires the use of both J201 and J202.

The Dual Camera Link interface can handle a maximum data rate of 6.8Gbps using 10-tap mode.

In addition, the MityCAM-B2521F supports base mode configurations for pixel depths of 16 bits (1 pixel per clock), 12 bits (2 pixels per clock), and 8 bits (2 pixels per clock).

Gigabit Ethernet (J4)

For the Gigabit Ethernet based MityCAM-B2521F a standard RJ45 Ethernet connector is used, J4.

Power Input (P200)

The MityCAM has a single power input connector on the rear of the units. This 4-pin LEMO ECG.0B.304.CLN connector, P200, utilizes 2-positive power input pins and 2-ground connections as shown below in Figure 6 and Table 3. Each kit includes an AC to 12V DC (3.3A) power adapter. Maximum current draw should be less than 1.4A.

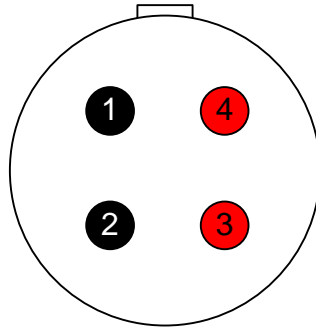

Figure 6: P200 Power Input Connector

Pin	Type	Description
1	GND	Ground
2	GND	Ground
3	PWR	+12VDC
4	PWR	+12VDC

Table 3: P200 Input power connector pin-out (P200)

Note that over voltage, under-voltage and reverse polarity protection is provided within the kit, however care should be taken if a non-standard adapter is used. The mating connector is a LEMO FGG.0B.304.CLAD52 or similar connector.

USB 2.0 Interface (J1)

The MityCAM features a standard Mini-B type USB connector on the rear of the unit. This interface is used for development purposes (e.g., software and firmware updates, low level access to camera functions) and supports lower speed image acquisition via a Windows PC application provided by Critical Link.

General Purpose IO (P201)

A total of 4 general purpose IOs are made available for the user via the P201 connector, LEMO ECG.0B.306.CLN, on the rear of the unit. The GPIOs utilize 5V TTL logic level and are ESD protected to standards exceeding JESD 22. Table 4 and Figure 7 show the pin-out for the GPIO interface connector. The GPIO signals are pulled up in the camera to +5V via a 1k Ohm resistor. A minimum voltage of 4.6V is required to drive the GPIO inputs to logic high, a maximum voltage of 0.15V is required to drive the GPIO inputs to logic low.

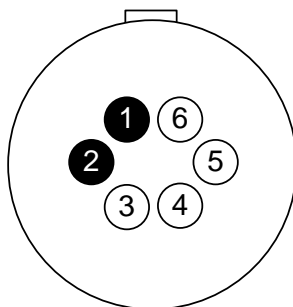

Figure 7: GPIO Interface Connector Pin Out (P201)

Pin	Type	Description	Altera SoC Pin (via level translator)
1	GND	Ground	
2	GND	Ground	
3	I/O	IO 3 - 5V TTL Logic Level	B3B_RX_B27_N
4	I/O	IO 2 - 5V TTL Logic Level	B3B_RX_B27_P
5	I/O	IO 1 - 5V TTL Logic Level	B3B_RX_B39_N
6	I/O	IO 0 - 5V TTL Logic Level Supports external trigger	B3B_RX_B39_P

Table 4: GPIO connector pin-out (P201)

The mating connector is a LEMO FGG.0B.306.CLAD52 or similar connector.

Table 5 shows the ESD protection specifications built into the MityCAM-B2521F for the GPIO pins.

ESD Standard	Rating
Human-Body Model (A114-B)	15-kV
Machine Model (A115-A)	200-V
Charged-Device Model (C101)	1000-V

Table 5: GPIO ESD Protection Standards

Cooling

The MityCAM-B2521F features an integrated single stage TEC cooler and low profile 50mm fan for the compact body style units, with an integrated heat sink via the case body. The TEC cooler is capable of holding the temperature to within +/- 0.5 degrees C of a setpoint that is no lower than 10 degrees above the ambient temperature. The fan can be enabled or disabled through the I²C based LED status light and fan controller. Accessing the fan controls is accomplished via the I²C bus 1 address 1100 010. The Camera Link serial interface and USB control interface provides a TEC and fan enable control command.

If using the board set only version in your custom design, proper cooling must be taken to ensure that the imaging sensor does not exceed the specified maximum temperature of **Table 2**.

Read-out rates (Rolling Shutter)

Array Size	Camera Link 10-tap	Camera Link Base Mode	Gigabit Ethernet	USB
5.5Mpixels x 16 bits	70 fps*	14 fps	3.6 fps	TBD
5.5Mpixels x 12 bits	70 fps*	28 fps (2 per clock)	N/A	TBD
5.5Mpixels x 8 bits	70 fps*	28 fps (2 per clock)	N/A	TBD
*70 fps is qualified with TEC designs, 100 fps has been demonstrated with board set (no TEC)				

Read-out rates (Global Shutter)

Array Size	Camera Link 10-tap	Camera Link Base Mode	Gigabit Ethernet	USB
5.5Mpixels x 16 bits	34.7 fps*	6.9 fps	3.6 fps	TBD
5.5Mpixels x 12 bits	34.7 fps*	13.9 fps	N/A	TBD
5.5Mpixels x 8 bits	34.7 fps*	13.9 fps	N/A	TBD
*34.7 fps is qualified with TEC designs, 50 fps has been demonstrated with board set (no TEC)				

EXTERNAL DIMENSIONS – CAMERA BODY

For customers desiring a completed camera assembly, Critical Link offers enclosed body models that can be used for final application development as shown in the figure below.



Figure 8 Camera Body shown with example lens and small tripod, side view



Figure 9 Camera Body shown with example lens and small tripod, rear view

Unless otherwise noted, all dimensions are in mm [inches].

Front Face Dimensions (Figure 10): 76.20[3.000] x 76.20[3.000]

Side Dimensions (Figure 11) Front Face to External Connectors: 72.28[2.846]

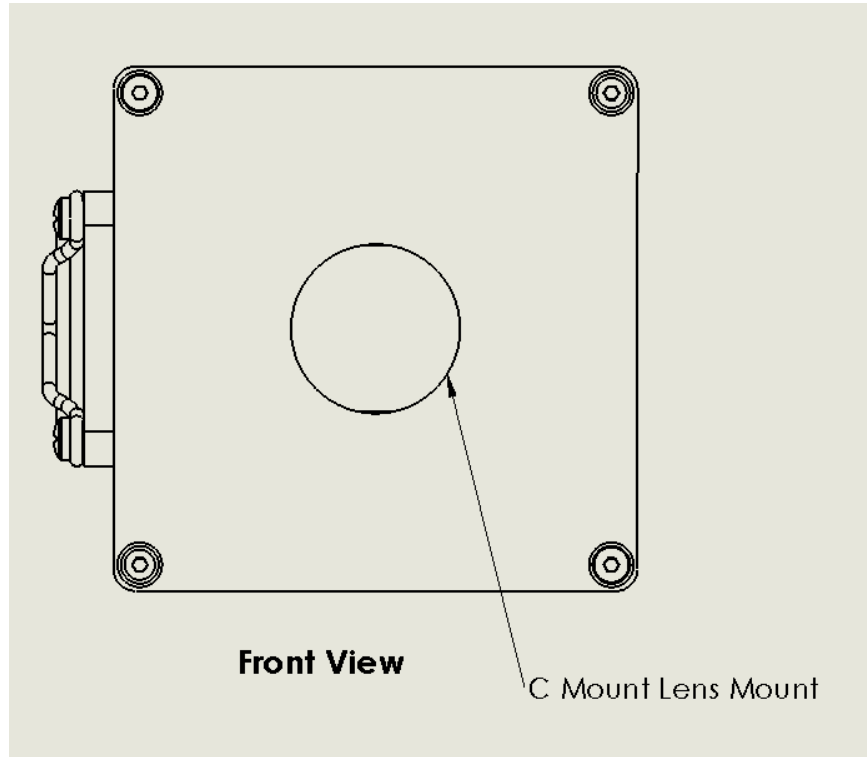

Figure 10: Body with 'C' Mount Lens Mount - Front View

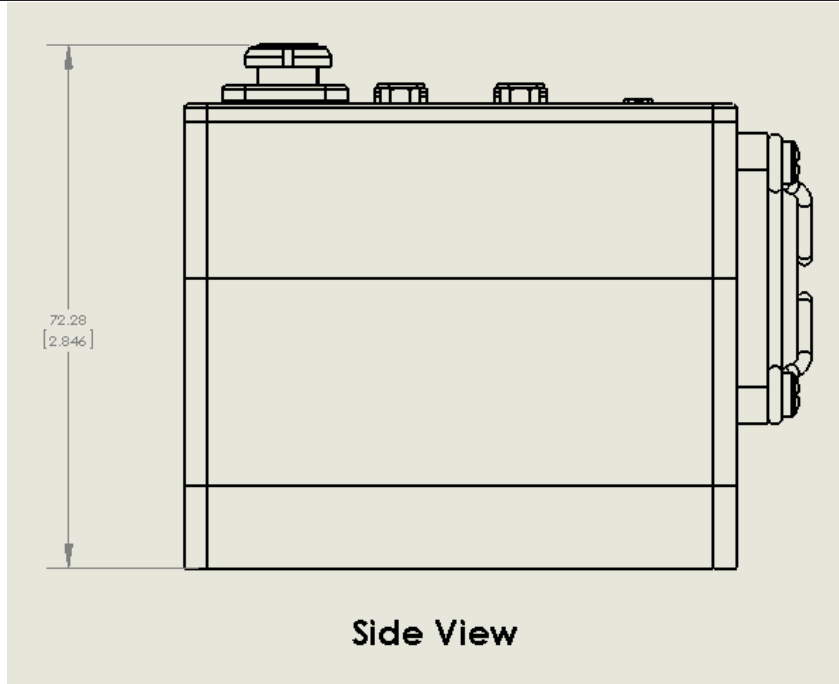

Figure 11: Body with 'C' Mount Lens Mount – Side View

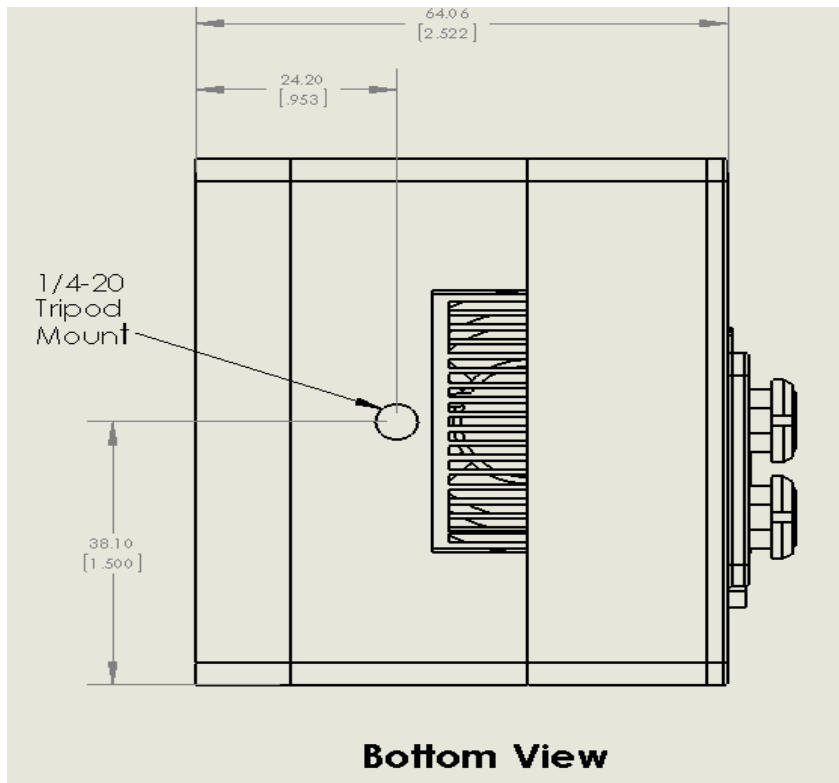

Figure 12: Body with Tripod Mount – Bottom View

EXTERNAL DIMENSIONS – BOARD SET ONLY

Critical Link can provide board set solutions if the compact body mechanical arrangement does not meet your application needs. Please contact your Critical Link representative for detailed drawings for a particular MityCAM-B2521F board set.

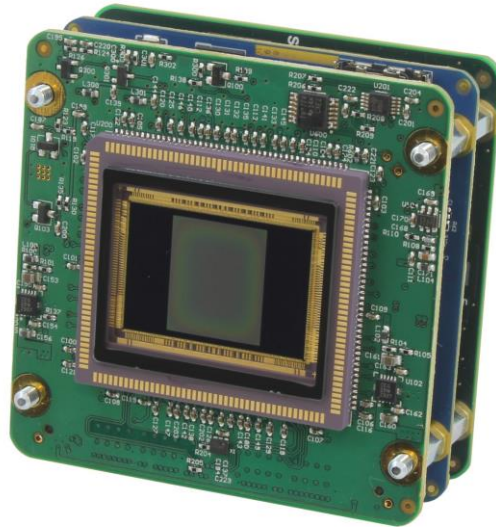

Figure 13: Board set photo

ORDERING INFORMATION

Table 6 below lists the standard configurations for the MityCAM-B2521F. For shipping status, availability, and lead time of these or other configurations please contact your Critical Link representative.

Table 7 below provides an accessory kit part number for the MityCAM-B2521F. This kit is required when evaluating the sensor or doing development, and is compatible with the camera body models listed in Table 6. It is not required for cameras that are being integrated into a working design.

Table 6: MityCAM-B2521F Standard Model Numbers

Model Number	Sensor Package	Sensor Window	Chroma	High Speed Interface	Body
B2521FTS-CM-C-S	Scientific	Sealed	Mono	Dual Camera Link	Camera
B2521FTS-CM-B-S	Scientific	Sealed	Mono	Dual Camera Link	Board-Set
B2521FTS-GM-C-S	Scientific	Sealed	Mono	Gigabit Ethernet	Camera
B2521FTS-GM-B-S	Scientific	Sealed	Mono	Gigabit Ethernet	Board-Set
B2521FTS-CC-C-S	Scientific	Sealed	Color	Dual Camera Link	Camera
B2521FTS-CC-B-S	Scientific	Sealed	Color	Dual Camera Link	Board-Set
B2521FTT-CM-C-S	Scientific	Temporary	Mono	Dual Camera Link	Camera
B2521FTT-CM-B-S	Scientific	Temporary	Mono	Dual Camera Link	Board-Set
B2521FTT-GM-C-S	Scientific	Temporary	Mono	Gigabit Ethernet	Camera
B2521FTT-GM-B-S	Scientific	Temporary	Mono	Gigabit Ethernet	Board-Set

Table 7: MityCAM-B2521F Accessory Kit Part Number

Part Number	MityCAM Compatibility	Kit Contents
80-000783	Compatible with all Camera Body models: B2521FTS-CM-C-S B2521FTS-GM-C-S B2521FTS-CC-C-S B2521FTT-CM-C-S B2521FTT-GM-C-S	Canon EF 50mm f/1.8 II Lens Lens Mount Adapter Tripod I/O Cable USB Cable Power Supply Ethernet Cable

REVISION HISTORY

Date	Change Description
27-Jan-14	Initial preliminary revision.
15-Jul-14	Updated per current measured performance.
02-Sep-14	Updated power supply requirements for TEC design. Updated Model Numbers. Clarified voltage inputs (12V +/- 10%). Clarified GPIO requirements.
24-Mar-15	Updated standard model numbers, accessory kit part number, read-out rates, and GPIO pin out descriptions.

REFERENCES

- [1] Fairchild Imaging, Available: <http://www.fairchildimaging.com>. [Accessed: January, 2014]
- [2] BAE Systems, “MAN 0101 CIS2521F Standard and Scientific Package Datasheet_RevF.pdf”, October 2013.