



## VLX Series Ultra Bright LED Line Lights

### Optimising High Speed Line Scan applications

**Ultra High Intensity Air and Water cooled LED Line lights for Line Scan applications, delivering the industry's highest performance levels.**

Typical applications include Web and Surface Inspection, Pharmaceutical quality control and Road/Rail inspection

- For applications needing the Fastest Line Scan Line rates
- Natural convection, Forced Air and Liquid-Cooled versions
- 100mm to 3.5m Light length
- Light Intensity to 2500kLux

#### **Faster Linescan Systems**

Gardasoft VLX Series Line Lights provide ultra-bright, uniform lighting focused to a narrow beam up to 2million Lux intensity. With VLX lighting, the Line Scan acquisition can operate many times faster than with conventional LED lights - allowing higher production speeds and/or higher resolution images.

#### **Replaces Fibre Optic Linelights**

The VLX Series of LED lights have been designed to provide a better alternative to fibre optic based systems. Compared to fibre optic light sources, there are no expensive bulbs to change, reducing costs and process down-time. The colour of the LEDs remains much more constant than filament or discharge bulbs.

#### **Uniform illumination**

Intensity profile adjustment allows the profile to be varied along the length to compensate for geometry variations in the system, resulting in uniform illumination along the whole camera sensor.

#### **Complete water cooled solution**

Water cooling is commonly used in industrial applications and is simple to implement on the Gardasoft VLX2 Series. All that is required is a cooler, flexible plastic pipework and self-sealing pipe connectors, and Gardasoft are able to supply this as a ready to connect kit. Existing on-site cooled water can also be used.

Water cooling allows the VLX2 lights to operate with increased brightness whilst maintaining the lifetime of the LEDs in excess of 50000 hours for all environmental conditions. Great emphasis has been placed upon intensity and thermal management to ensure efficient, reliable and consistent operation and fast 'warm-up' time. The units will automatically switch off in the event of cooling failure to prevent damage.

#### **Control Interface**

The light output from the VLX units can be varied over a very wide range and is either preset or controlled via a communication interface. The system temperature and individual LED device failure detection can be monitored.

# VLX Series

## Narrow form factor

The narrow form factor of the VLX2 Line Lights allow much smaller mounting angles between camera and light to be achieved.

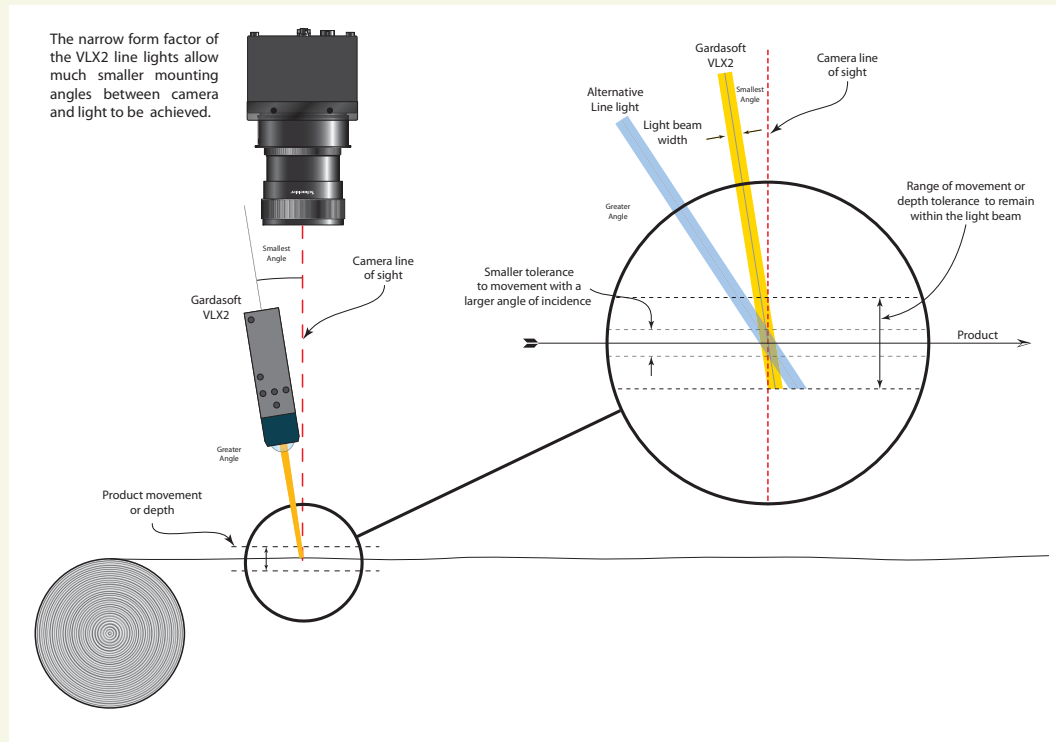

## Diffuser option

When objects are inspected as in the example below, with conventional Line Lights unwanted reflections from the individual LEDs in the light can occur. The VLX Series offers the added advantage of a Diffuser option which overcomes this issue for Specular reflection applications.

## Diffuser Option

When objects are inspected as in the example below, unwanted reflections of the individual LEDs can occur

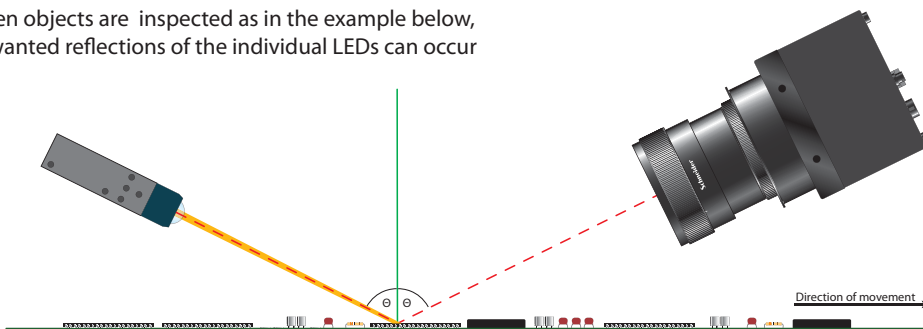

Where illumination requires a "Specular" arrangement as shown above with a potentially reflective product, bright "stripes" may be seen in the image due to the camera "seeing" the discrete LEDs in the line light.



By using the optional diffuser this effect can be eliminated. The diffuser smoothes out the variations along the line without increasing its width. However, the diffuser option should only be used where necessary as it does cause a reduction in the output intensity due to increased spread of light and pass-through losses.



## VLX1

### SPECIFICATIONS

Parameter	VLX1 (convection cooled version)
Line uniformity	>95% excluding the end 30mm for SWD and 40mm for LWD
Standard Line Light lengths	100mm, 200mm, 300mm, 400mm, 500mm, 1000mm, 1200mm, 1500mm, 2000mm. Other lengths available on request
Profile adjustment resolution	33.3mm segments
Working distance options	SWD option - 37mm fixed LWD option - 90mm to 110mm variable
Line thickness at 37mm Working Distance	3mm
Supply voltage	15V to 26V DC (specific to wavelength)
Typical supply current at 100% brightness	10A per metre maximum
Control/communication	RS232
Lifetime (degrade to 70% brightness)	>50000 hours at 100% (depends on ambient temperature)
Width	41mm
Height (37mm Working Distance)	95mm (plus cable entries)
Length (without Fans)	Lighting length plus 20mm
Mounting	M5 tapped holes
Weight	Approx. 5.0Kg per metre
Operating temperature	-20°C to +50°C (affects intensity performance)
Storage temperature	-20°C to +70°C
Environmental protection	IP50 standard, others on request

Colour <sup>4</sup>	Peak wavelength	Luminous Flux per metre <sup>1 3</sup>	Max Luminous Intensity at 3mm Line Thickness <sup>2 3</sup>
White	Cool white (6500k typical)	18000 lm	1800 kLux
Green	530nm	12000 lm	1200 kLux
Amber	617nm	7000 lm	720 kLux
Red	627nm	7000 lm	720 kLux
Blue	470nm	2500 lm	360 kLux
IR	740nm	20 W	2000W/m <sup>2</sup>
	850nm	22 W	2200W/m <sup>2</sup>
UV	400nm	38 W	3600W/m <sup>2</sup>

- Notes:**
1. Total power output from the LEDs (calculated)
  2. Absolute Maximum intensity at illuminated surface based on 20mm optics, working distance 37mm. 110mm WD is approximately 50% less
  3. Figures for convection cooled versions are dependent on the surrounding conditions
  4. Other colours available on request

### ORDERING INFORMATION

#### VLX1 Part Number Format

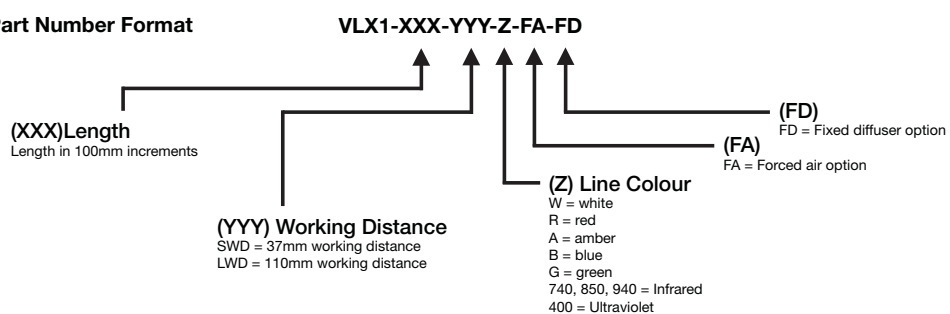

**VLX2**

**SPECIFICATIONS**

Parameter	VLX2
Line uniformity	>95% excluding the end 40mm for SWD and 50mm for LWD
Standard Line Light lengths	250mm, 375mm, 500mm, 1000mm, 1500mm, 2000mm. Other lengths available on request
Profile adjustment resolution	62.5mm segments
Working distance options	SWD option - 37mm fixed LWD option - 90mm to 110mm variable
Line thickness at 37mm Working Distance	3mm
Supply voltage	15V to 26V DC (specific to wavelength)
Typical supply current at 100% brightness	16.5 A per metre maximum (<16.5A for Red, UV and IR)
Control/communication	RS232
Lifetime (degrade to 70% brightness)	>50000 hours at 100% ~20000 hours at 140%
Width	30mm
Height (37mm WD)	109mm
Length (without Cooling or Fans)	Lighting length plus 52mm
Mounting	M5 tapped holes
Weight	Approx 5.6Kg per metre
Operating temperature	-20°C to +50°C
Storage temperature	-20°C to +70°C
Environmental protection	IP50 standard, others on request

Colour <sup>4</sup>	Peak wavelength	Luminous Flux per metre <sup>1,3</sup>	Max Luminous Intensity at 3mm Line Thickness <sup>2,3</sup>
White	Cool white (5000-5700K)	23000 lm	2300 kLux
Green	530nm	16000 lm	1600 kLux
Amber	617nm	9600 lm	960 kLux
Red	627nm	9600 lm	960 kLux
Blue	470nm	4800 lm	480 kLux
IR	740nm	12 W	1250 W/m <sup>2</sup>
	850nm	91 W	9100 W/m <sup>2</sup>
	940nm	48 W	4800 W/m <sup>2</sup>
UV	365nm Standard	7.5 W	750 W/m <sup>2</sup>
	365nm High Power	35 W	3500 W/m <sup>2</sup>
	400nm	34 W	3400 W/m <sup>2</sup>

- Notes:**
1. Total power output from the LEDs (calculated)
  2. Absolute Maximum intensity at illuminated surface based on 20mm optics, working distance 37mm. 110mm WD is approximately 50% less
  3. Figures for convection cooled version, which are dependent on the surrounding conditions
  4. Other colours available on request

**ORDERING INFORMATION**

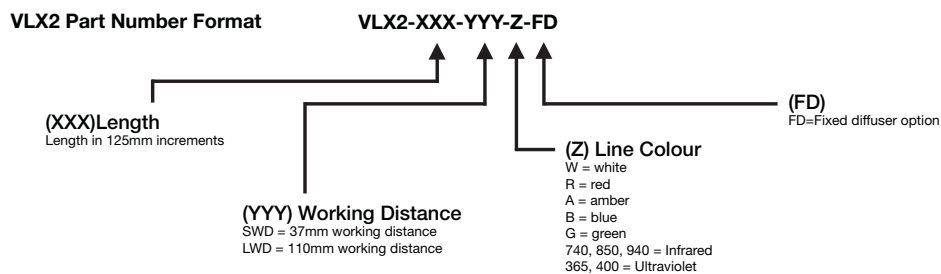

© 2012 Gardasoft Vision Ltd. All trademarks acknowledged. Specifications are subject to change without notice