

REVISIONS			
REV.	DESCRIPTION	DATE	APPROVED
A	INITIAL RELEASE	10/19/2017	
B	BOM UPDATE	2/9/2018	
C	REMOVED HEAT SINK FROM STANDARD	2/27/2018	

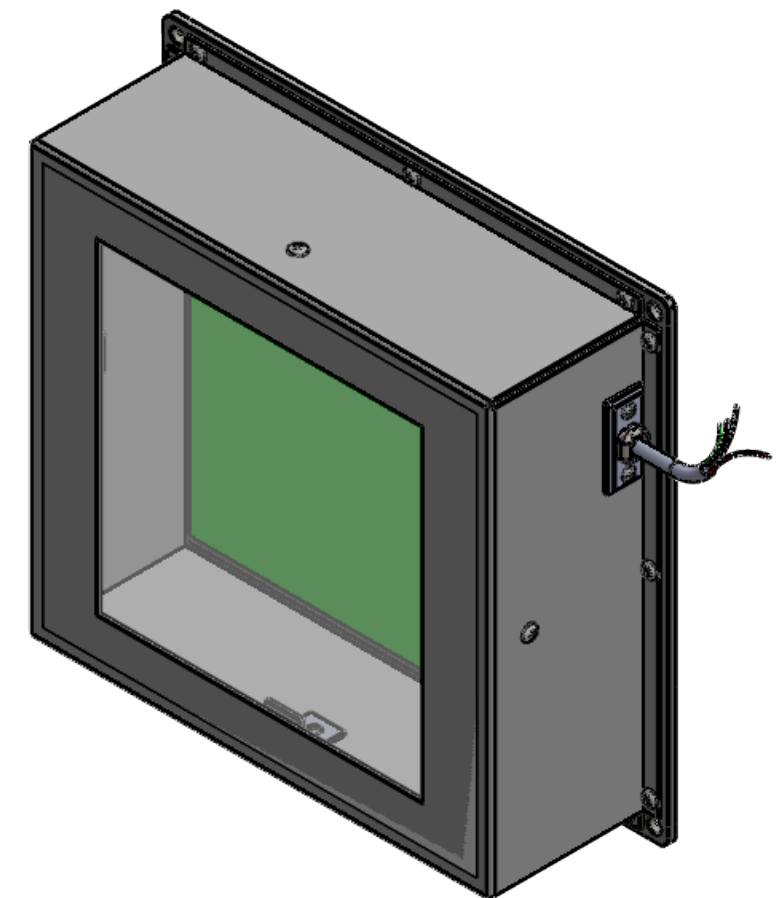

Metaphase Technologies, Inc. 211 Sinclair Road, Suite 100, Bristol, PA. 19007 215-639-8699 Fax 215-639-0977

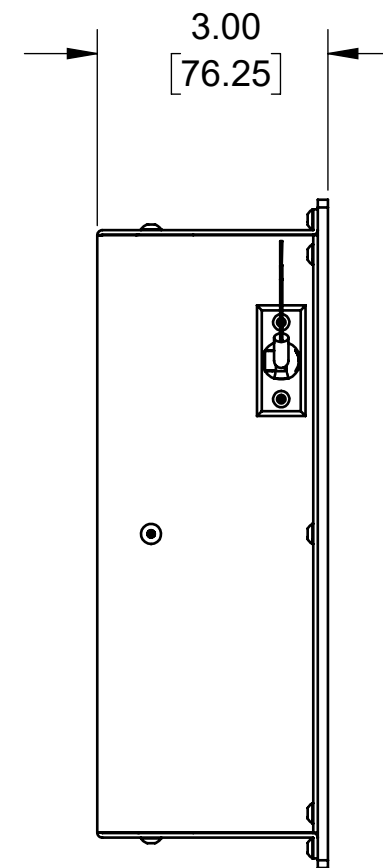
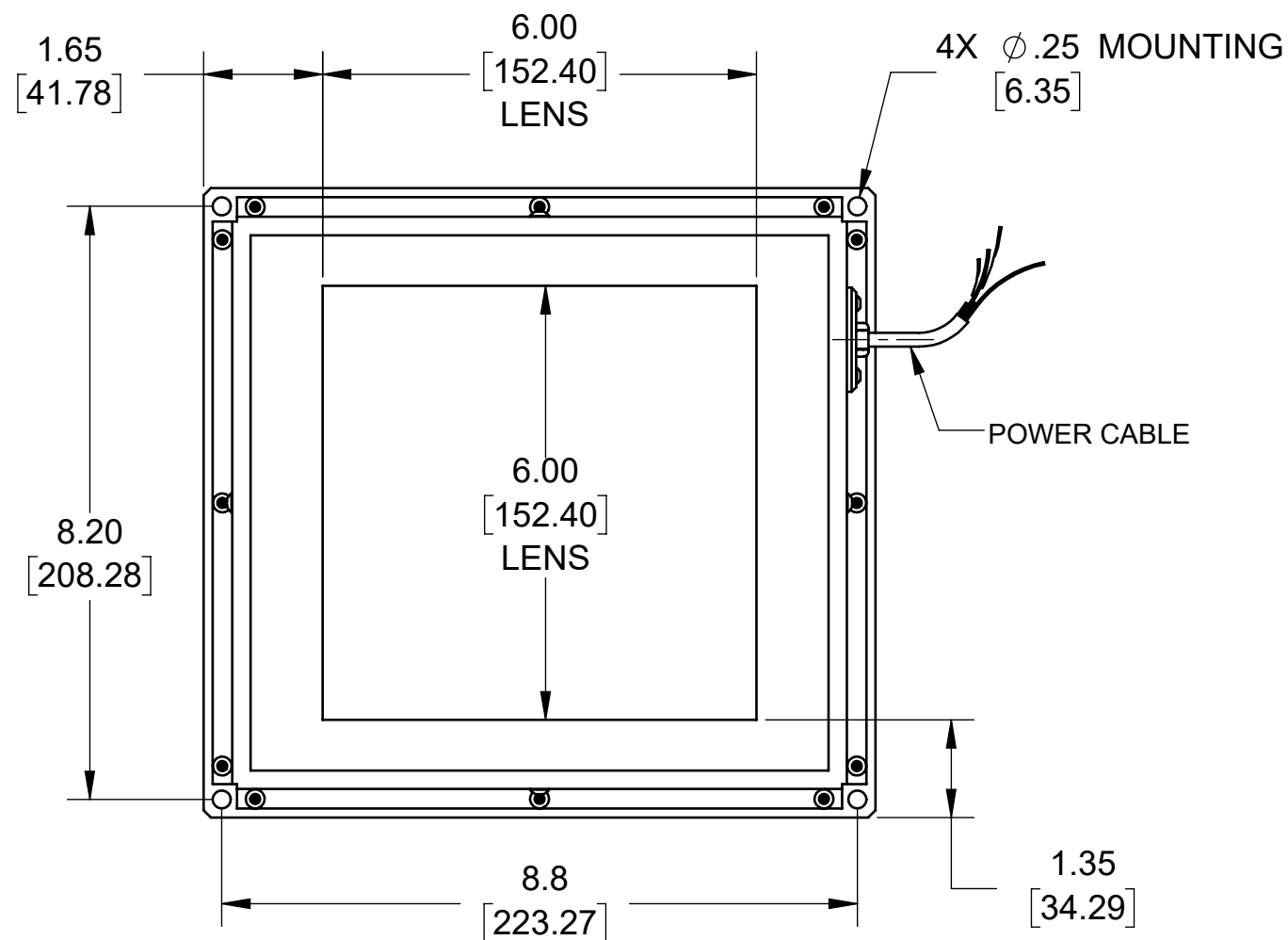

**QUANTITY:** Per order

**MATERIAL:** Per BOM

**FINISH:** Black Polane

**TREATMENT:** N/A

TOLERANCE/FINISH  
UNLESS OTHERWISE SPECIFIED

INCHES [MM]				125 $\sqrt$ RMS [RA3.2 $\mu$ m]
X	.X	.XX	.XXX	ANGLES $\pm$ 1°
[ $\pm$ .76]	$\pm$ .030 [ $\pm$ .25]	$\pm$ .010 [ $\pm$ .13]	$\pm$ .005	

THIS DOCUMENT IS THE PROPERTY OF METAPHASE TECHNOLOGIES, INC. WHOM MAY LOAN IT, SUBJECT TO RETURN UPON DEMAND. IT INCLUDES CONFIDENTIAL & PROPRIETARY INFORMATION WHICH MAY NOT BE DISCLOSED TO ANY THIRD PARTY, AND/ OR USED FOR ANY PURPOSE CONTRARY TO IT'S INTENDED USE, WITHOUT THE EXPRESSED PRIOR WRITTEN CONSENT OF METAPHASE TECHNOLOGIES, INC.

TITLE  
ASSY, BACKLIGHT, 6X6

USED ON  
Per customer

SIZE <b>B</b>	DRAWING NUMBER <b>MS-BL6X6-1</b>	REV <b>C</b>
SCALE 1:2		SHEET 1 OF 1

SEE SHEET 2 FOR EXPLODED VIEW AND BOM.

Approval Signature

/ /  
Date