

TX Series Backlight

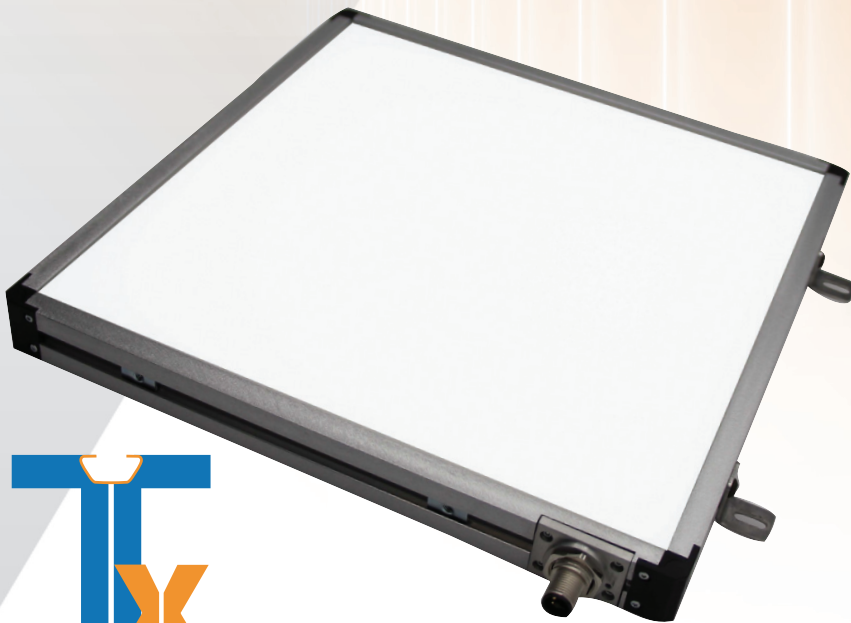

Advanced Performance for Machine Vision
Inspection, Measurement, and Gauging

The TX Back Light Difference

The TX Series of Back Lights provides superior performance for the most demanding machine vision applications.

The latest High Density Precision Chip Technology (HDPCT) produces impressive intensity and uniformity across the full array (edge-to-edge). State-of-the-art driver technology delivers instant start-up and flicker-free operation. Optimize your application, maintain flexibility and minimize technical risk with the exceptional results obtained from the TX Series Back Lights from Metaphase Lighting Technologies.

- ✓ **Best for high-contrast, high-accuracy** inspection, measurement and gauging applications.
- ✓ **Low-profile housing with 10mm bezel**, ideal for space-limited applications.
- ✓ **Maximum installation flexibility** with 180-degree adjustable T-slot L-brackets (included).
- ✓ **High-uniformity and brightness** provided by a full array of high-density LEDs.
- ✓ **Application flexibility** with six available wavelengths (R,G,B, W, IR850, IR940).
- ✓ **Multispectral: 35 possible combinations** by selecting up to four colors.

Features

- 4-sided T-slot based aluminum extrusion. T-nuts supplied. (M4-0.7p x 6mm hex key head).
- Ultra-Slim 10mm housing bezel, maximizes active area relative to footprint.
- Compact 25mm height, available with either internal (-DC) driver or external (-U) drivers (with over-driving strobe).
- External Trigger Included.
- Bulkhead 5-pin M12 A-code connector(s) for DC version, 4-pin M12 T-code for external driver version.
- Built-in high-efficiency, dimmable, constant current driver (DC Version).
- Optional polarizer filter is a simple field replace/retrofit.

Ordering Info

TXBL/ TXCBL Part Numbers and Sizes

TXBL available in 25mm (1 in nominal) increments, up to 1000x1000 mm



TX Series
Back Light



TABLE 1: PART NUMBER KEY

Contact your Metaphase Sales representative for custom versions (intensity, uniformity, wavelengths, sizes, etc).

Family	Active Area (1 unit = 25mm)	Wavelength	Drive	Polarizer	Connector Location
TXBL TXCBL	XXXX (small dimension first)	XXXXXX	XX	XXXXX	Blank if No Modification
TXBL	0202-1640	W (White 5700K, Nominal)	DC (24VDC)	Blank if no polarizer	Long-side, right is the default M12 location. Contact Metaphase for custom M12 locations.
TXCBL	0202-1616	B (Blue 470nm)	U (Universal LED Controller, ULC)	POL0	
(Collimated)		G (Green 530nm)		POL90	
		R (Red 630nm)			
		IR850 (Infrared 850nm)			
		RGB (630nm, 520nm, 470nm)			
		RGBW (630nm, 520nm, 470nm, 5700K)			
		WIR850 (850nm, 5700K)			
		WIR940 (940nm, 5700K)			

Example 1: TXBL0412-R-DC

Back Light – 100mm x 300mm – Red – DC Operation – No Modification

Example 2: TXCBL1016-WIR850-DC-SSL

Collimated Back Light – 250mm x 400mm – White and IR850 – DC Operation, Short Side Left connector location – No Modification

Accessories	Part Number	Description
DC Version		
DDC Controller	DDC-3	DIGITAL DIMMING CONTROLLER, 3-CHAN 0-10V OUTPUT <i>Note: Requires 24VDC, 1A power supply</i>
3m cable	CAB-FM12FL-3M	3 METER EXTENSION CABLE, FEMALE M-12 A-CODE 5-PIN TO FLYING LEADS
5m cable	CAB-FM12FL-5M	5 METER EXTENSION CABLE, FEMALE M-12 A-CODE 5-PIN TO FLYING LEADS
10m cable	CAB-FM12FL-10M	10 METER EXTENSION CABLE, FEMALE M-12 A-CODE 5-PIN TO FLYING LEADS
U Version		
ULC-2 Controller	ULC-2	UNIVERSAL LED CONTROLLER, TWO-CHANNEL, WITH ULC-2 CONNECTORS <i>Note: Requires 24VDC power supply, 6.7A, to run at full capability</i>
3m cable	CAB-FM12TU-3M - For 1 channel	3 METER EXTENSION CABLE, FEMALE M12 T-CODE 4-PIN TO ONE ULC CONNECTOR, LED POS ON PIN 1&2, LED NEG ON PINS 3&4
3m cable	CAB-FM12T2U-3M - For 2 channels	3 METER EXTENSION CABLE, FEMALE M12 T-CODE 4-PIN TO TWO ULC CONNECTOR, LED POS CHAN A&B ON PINS 1&2, LED NEG CHAN A&B ON PINS 3&4

Available Wavelengths

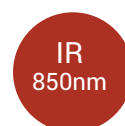
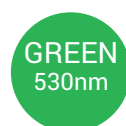

*Note:
Available in
many more color
combinations*



General	
Operating Temperature	0-40°C, 90% RH, non-condensing*
IP Rating	IP50
Storage Temperature	0-70°C, 90% RH, non-condensing
Compliance	RoHs, CE, IEC 61000-6-2, 61000-6-4, 61010-1
Photobiological Risk Factor**	Exempt
Warranty	2 Years
* Contact your Metaphase sales engineer for higher temperature environments.	
**Full documentation available upon request.	
Electrical	
Supply Voltage	24VDC+/-5%
DC Version (-DC)	
0-10V Dimming Control (TXBL TXCBL)	Off: 0V Turn-on Threshold: 0.9V 100% Intensity: 10V <i>Note: 0-10V Must be connected to turn light on and to trigger.</i> Maximum allowance voltage: 10V-24V
Input Impedance	≥180kΩ/1300 cm ² increment, per wavelength
External Controller Version (-U)	
Forward Voltage (DC mode)	W: 11.2VDC Red: 7.2VDC Green: 11.6VDC Blue: 11.2VDC IR850 or IR940: 5.2VDC
Trigger Input:	
Min Trigger Pulse = 2.5µs	PNP (See Figure 1)
Max trigger rate = 5 kHz	Voltage Enable > 1.39V
Trigger turn-on delay = 51µs	Voltage Disable < .56V
Trigger turn-off delay = 5µs	NPN (See Figure 2)
	Input Impedance = 10kΩ
<i>Note : For continuously ON @ full intensity connect 24VDC power supply to +24V, 0-10VDC and PNP trigger-in inputs</i>	
Optical	
Light Source	LED
LED Array Density	High Density Precision Chip Technology (HDPCT)
Available Wavelengths	470, 530, 630, 850, 940
Intensity	W - 86,000 Lux, R - 79,000 Lux, G - 79,000 Lux, B - 12,000 Lux
Available Color Combinations	W(5700K), RGB, RGBW, WIR850 (5700K/850), WIR940 (5700K/940)
Lifetime	L70 = 75,000 hours
Polarizer (Optional and field-installable by removing one side rail with T6 wrench)	

Mechanical (all units metric)

Housing	25mm profile with 10mm bezel, made of clear anodized aluminum
Mounting	(2) T-nuts minimum per side, pre-installed
Outside Dimensions (OD)	OD = Active Area + 20mm (see Figure 12)
Active Area Designation	Part Number "TXBLXXYY" indicates the Active Area is "Ax" by "Ay" See Table 1 "Part Number Key"
L-Bracket Mounting	Center-to-center mounting hole distance = Active Area + 40mm (see Figure 13)
Fasteners	M4-0.7px6mm hex key head
Weight (kg/mm ²)	See Table 6: "Weight (kg) for Active Area Width and Length"
Bulkhead Male M12	See Table 4: "Max Current Draw and Number of Connectors per Size (-DC Version)" Note: "Long Side Right" is default location.

TXBL/ TXCBL M12A Connector, DC version



M12A Bulkhead, 5-pos male TXBL Interface
Cable with M12A female connector

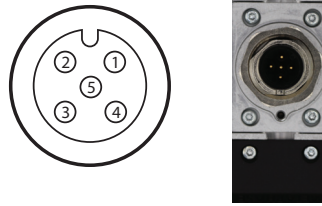
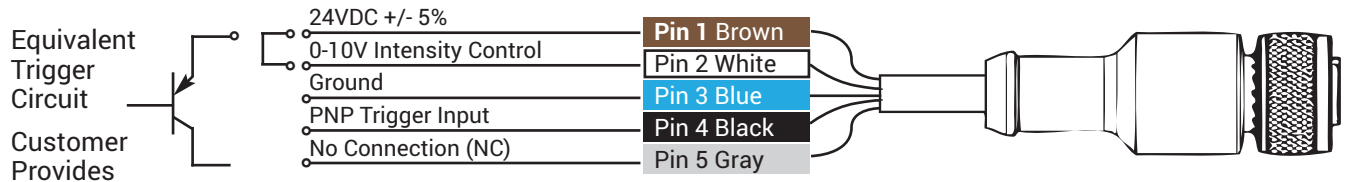
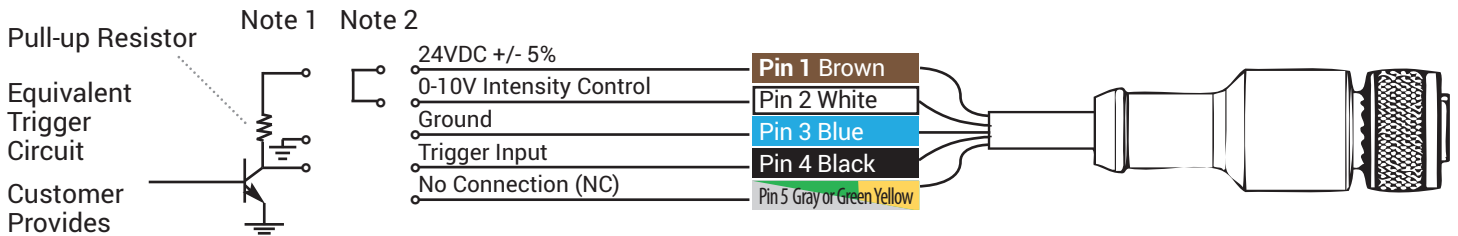

FIGURE 1: TXBL INTERFACE CABLE, M12 5-PIN A-CODE FEMALE CONNECTOR, CONFIGURED FOR PNP TRIGGER



Note: For continuously ON @ full intensity connect 24VDC power supply to +24V , 0-10VDC and PNP trigger-in inputs.

FIGURE 2: TXBL INTERFACE CABLE, M12 5-PIN A-CODE FEMALE CONNECTOR, CONFIGURED FOR NPN TRIGGER



Note 1 for NPN Trigger Input: Connect 47kΩ ohm or less between 24VDC and Trig NPN pulls down below .5V to DISABLE light output 1kHz max Trigger Rate.

Note 2 for No Dimming Control Connect 0-10V Intensity Control to 24VDC for maximum intensity without control.

See Table 1A: Part Number Key for Cable Part Number by length

TABLE 2: TXBL/TXCBL INTERFACE CABLE WITH AN M12A FEMALE CONNECTOR

M12A Wiring					
Connector #1	Pin 1	Pin 2	Pin 3	Pin 4	Pin 5
1 Wavelength (Note 1)	24V	Wavelength #1: 0-10V	GND	TRG	NC
2 Wavelengths (Note 1)	24V	Wavelength #1: 0-10V	GND	TRG	Wavelength #2 : 0-10V
3 Wavelengths	24V	Wavelength #1: 0-10V	GND	TRG	Wavelength #2: 0-10V
4 Wavelengths	24V	Wavelength #1: 0-10V	GND	TRG	Wavelength #2: 0-10V
Connector #2					
1 Wavelength (Note 1)	24V	NC	GND	NC	NC
2 Wavelengths (Note 1)	24V	NC	GND	NC	NC
3 Wavelengths	24V	Wavelength #3: 0-10V	GND	NC	NC
4 Wavelengths	24V	Wavelength #3: 0-10V	GND	NC	Wavelength #4: 0-10V
Connector #3					
All Lights requiring 3 or 4 connectors	24V	NC	GND	NC	NC
Connector #4					
Not applicable	24V	NC	GND	NC	NC

Note 1: Additional Connector may be required. See Table 4: Max Current Draw and Number of Connectors per Size (-DC Version)



M12 4-pin T-Code Bulkhead

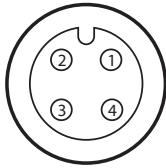
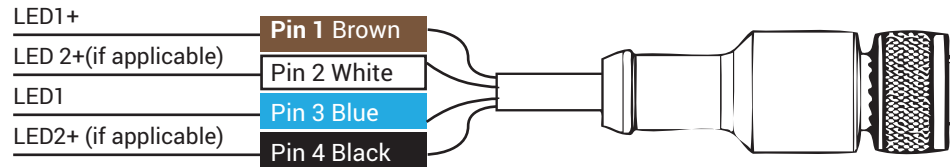

FIGURE 3: CABLE COLOR CODE, M12T CONNECTOR

Pin	Function	Wire Color
1	LED1+	Brown
2	LED2+ (if applicable)	White
3	LED1	Blue
4	LED2+ (if applicable)	Black

FIGURE 4: TXBL INTERFACE CABLE WITH AN M12 4-PIN T-CODE FEMALE CONNECTOR



See Table 1: Part Number Key for Cable Part Number by length.

TABLE 3: TXBL INTERFACE CABLE WITH AN M12 4-PIN T-CODE FEMALE CONNECTOR

M12T Wiring				
Connector #1	Pin 1	Pin 2	Pin 3	Pin 4
1 Wavelength	LED+	LED+	LED 1-	LED-
2 Wavelengths	LED+	LED 2+	LED 1-	LED 2-
3 Wavelengths	LED+	LED 2+	LED 1-	LED 2-
4 Wavelengths	LED+	LED 2+	LED 1-	LED 2-
Connector #2				
1 Wavelength				
2 Wavelengths				
3 Wavelengths	LED 3+	NC	LED 3-	NC
4 Wavelengths	LED 3+	LED 4+	LED 3-	LED 4-

ULC-2 CONTROLLER

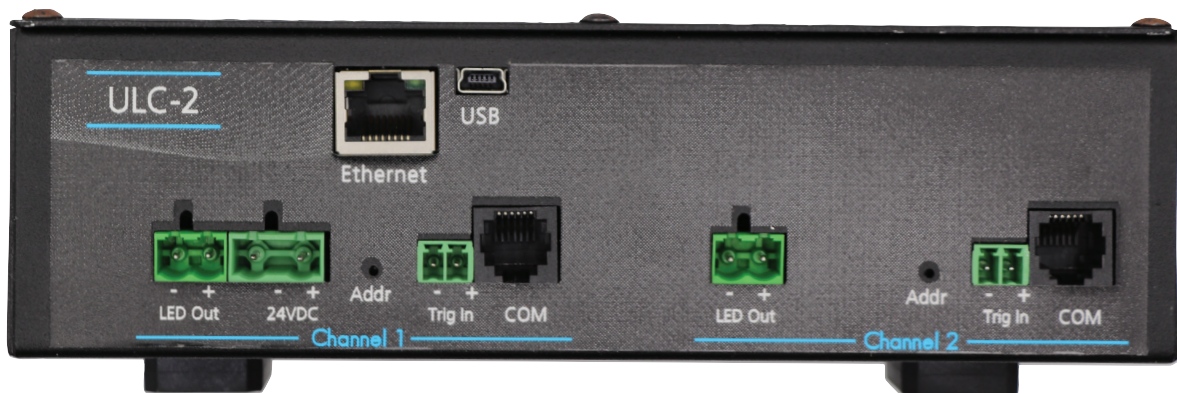



TABLE 4: MAX CURRENT DRAW AND NUMBER OF CONNECTORS PER SIZE (-DC VERSION)

		XX															
TXBL	02	03	04	05	06	07	08	09	10	11	12	13	14	15	16		
02	0.06																
03	0.10	0.15															
04	0.13	0.19	0.26														
05	0.16	0.24	0.32	0.40													
06	0.19	0.29	0.39	0.49	0.58												
07	0.23	0.34	0.45	0.57	0.68	0.79											
08	0.26	0.39	0.52	0.65	0.78	0.91	1.04										
09	0.29	0.44	0.58	0.73	0.87	1.02	1.17	1.31									
10	0.32	0.49	0.65	0.81	0.97	1.13	1.29	1.46	1.62								
11	0.36	0.53	0.71	0.89	1.07	1.25	1.42	1.60	1.78	1.96							
12	0.39	0.58	0.78	0.97	1.17	1.36	1.55	1.75	1.94	2.1	2.3						
13	0.42	0.63	0.84	1.05	1.26	1.47	1.68	1.89	2.1	2.3	2.5	2.7					
14	0.45	0.68	0.91	1.13	1.36	1.59	1.81	2.0	2.3	2.5	2.7	2.9	3.2				
15	0.49	0.73	0.97	1.21	1.46	1.70	1.94	2.2	2.4	2.7	2.9	3.2	3.4	3.6			
16	0.52	0.78	1.04	1.29	1.55	1.81	2.1	2.3	2.6	2.8	3.1	3.4	3.6	3.9	4.1		
17	0.55	0.83	1.10	1.38	1.65	1.93	2.2	2.5	2.8	3.0	3.3	3.6	3.9	4.1	4.4		
18	0.58	0.87	1.17	1.46	1.75	2.0	2.3	2.6	2.9	3.2	3.5	3.8	4.1	4.4	4.7		
19	0.61	0.92	1.23	1.54	1.84	2.2	2.5	2.8	3.1	3.4	3.7	4.0	4.3	4.6	4.9		
20	0.65	0.97	1.29	1.62	1.94	2.3	2.6	2.9	3.2	3.6	3.9	4.2	4.5	4.9	5.2		
21	0.68	1.02	1.36	1.70	2.0	2.4	2.7	3.1	3.4	3.7	4.1	4.4	4.8	5.1	5.4		
22	0.71	1.07	1.42	1.78	2.1	2.5	2.8	3.2	3.6	3.9	4.3	4.6	5.0	5.3	5.7		
23	0.74	1.12	1.49	1.86	2.2	2.6	3.0	3.4	3.7	4.1	4.5	4.8	5.2	5.6	6.0		
24	0.78	1.17	1.55	1.94	2.3	2.7	3.1	3.5	3.9	4.3	4.7	5.0	5.4	5.8	6.2		
25	0.81	1.21	1.62	2.0	2.4	2.8	3.2	3.6	4.0	4.5	4.9	5.3	5.7	6.1	6.5		
26	0.84	1.26	1.68	2.1	2.5	2.9	3.4	3.8	4.2	4.6	5.0	5.5	5.9	6.3	6.7		
27	0.87	1.31	1.75	2.2	2.6	3.1	3.5	3.9	4.4	4.8	5.2	5.7	6.1	6.6	7.0		
28	0.91	1.36	1.81	2.3	2.7	3.2	3.6	4.1	4.5	5.0	5.4	5.9	6.3	6.8	7.3		
29	0.94	1.41	1.88	2.3	2.8	3.3	3.8	4.2	4.7	5.2	5.6	6.1	6.6	7.0	7.5		
30	0.97	1.46	1.94	2.4	2.9	3.4	3.9	4.4	4.9	5.3	5.8	6.3	6.8	7.3	7.8		
31	1.00	1.51	2.0	2.5	3.0	3.5	4.0	4.5	5.0	5.5	6.0	6.5	7.0	7.5	8.0		
32	1.04	1.55	2.1	2.6	3.1	3.6	4.1	4.7	5.2	5.7	6.2	6.7	7.3	7.8	8.3		
33	1.07	1.60	2.1	2.7	3.2	3.7	4.3	4.8	5.3	5.9	6.4	6.9	7.5	8.0	8.5		
34	1.10	1.65	2.2	2.8	3.3	3.9	4.4	5.0	5.5	6.1	6.6	7.2	7.7	8.3	8.8		
35	1.13	1.70	2.3	2.8	3.4	4.0	4.5	5.1	5.7	6.2	6.8	7.4	7.9	8.5	9.1		
36	1.17	1.75	2.3	2.9	3.5	4.1	4.7	5.2	5.8	6.4	7.0	7.6	8.2	8.7	9.3		
37	1.20	1.80	2.4	3.0	3.6	4.2	4.8	5.4	6.0	6.6	7.2	7.8	8.4	9.0	9.6		
38	1.23	1.84	2.5	3.1	3.7	4.3	4.9	5.5	6.1	6.8	7.4	8.0	8.6	9.2	9.8		
39	1.26	1.89	2.5	3.2	3.8	4.4	5.0	5.7	6.3	6.9	7.6	8.2	8.8	9.5	10.1		
40	1.29	1.94	2.6	3.2	3.9	4.5	5.2	5.8	6.5	7.1	7.8	8.4	9.1	9.7	10.4		

Example

Part Number sequence: TXBLXXYY:

- XX = shortest dimension, YY is \geq XX
- One unit of measurement = 25mm of active area: TXBL0410 is 100mm x 250mm active area
- The TXBL0812 requires a quantity of one (1) M12A connector; Current = 2.1A

Legend

- Requires (1) M12
- Requires (2) M12
- Requires (3) M12

TXBL/ TXCBL ULC Settings vs. Size



TABLE 5: ULC SETTINGS DC PER CHANNEL (AMPS) PER SIZE

		XX															
TXBL	02	03	04	05	06	07	08	09	10	11	12	13	14	15	16		
02	0.1																
03	0.2	0.3															
04	0.2	0.3	0.4														
05	0.3	0.4	0.6	0.7													
06	0.3	0.5	0.7	0.8	1.0												
07	0.4	0.6	0.8	1.0	1.2	1.4											
08	0.4	0.7	0.9	1.1	1.3	1.6	1.8										
09	0.5	0.8	1.0	1.3	1.5	1.8	2.0	2.3									
10	0.6	0.8	1.1	1.4	1.7	2.0	2.2	2.5	2.8								
11	0.6	0.9	1.2	1.5	1.8	2.2	2.5	2.8	3.1	3.4							
12	0.7	1.0	1.3	1.7	2.0	2.4	2.7	3.0	3.4	3.7	2.0						
13	0.7	1.1	1.5	1.8	2.2	2.5	2.9	3.3	3.6	2.0	2.2	2.4					
14	0.8	1.2	1.6	2.0	2.4	2.7	3.1	3.5	3.9	2.2	2.4	2.5	2.7				
15	0.8	1.3	1.7	2.1	2.5	2.9	3.4	3.8	2.1	2.3	2.5	2.7	2.9	3.2			
16	0.9	1.3	1.8	2.2	2.7	3.1	3.6	2.0	2.2	2.5	2.7	2.9	3.1	3.4	3.6		
17	1.0	1.4	1.9	2.4	2.9	3.3	3.8	2.1	2.4	2.6	2.9	3.1	3.3	3.6	2.5		
18	1.0	1.5	2.0	2.5	3.0	3.5	2.0	2.3	2.5	2.8	3.0	3.3	3.5	2.5	2.7		
19	1.1	1.6	2.1	2.7	3.2	3.7	2.1	2.4	2.7	2.9	3.2	3.5	2.5	2.7	2.8		
20	1.1	1.7	2.2	2.8	3.4	3.9	2.2	2.5	2.8	3.1	3.4	2.4	2.6	2.8	3.0		
21	1.2	1.8	2.4	2.9	3.5	2.1	2.4	2.6	2.9	3.2	3.5	2.5	2.7	2.9	3.1		
22	1.2	1.8	2.5	3.1	3.7	2.2	2.5	2.8	3.1	3.4	2.5	2.7	2.9	3.1	3.3		
23	1.3	1.9	2.6	3.2	3.9	2.3	2.6	2.9	3.2	3.5	2.6	2.8	3.0	3.2	3.4		
24	1.3	2.0	2.7	3.4	2.0	2.4	2.7	3.0	3.4	2.5	2.7	2.9	3.1	3.4	3.6		
25	1.4	2.1	2.8	3.5	2.1	2.5	2.8	3.2	3.5	2.6	2.8	3.0	3.3	3.5	3.7		
26	1.5	2.2	2.9	3.6	2.2	2.5	2.9	3.3	2.4	2.7	2.9	3.2	3.4	3.6	3.9		
27	1.5	2.3	3.0	3.8	2.3	2.6	3.0	3.4	2.5	2.8	3.0	3.3	3.5	3.8	3.0		
28	1.6	2.4	3.1	3.9	2.4	2.7	3.1	3.5	2.6	2.9	3.1	3.4	3.7	3.9	3.1		
29	1.6	2.4	3.2	2.0	2.4	2.8	3.2	3.7	2.7	3.0	3.2	3.5	3.8	3.0	3.2		
30	1.7	2.5	3.4	2.1	2.5	2.9	3.4	2.5	2.8	3.1	3.4	3.6	3.9	3.2	3.4		
31	1.7	2.6	3.5	2.2	2.6	3.0	3.5	2.6	2.9	3.2	3.5	3.8	3.0	3.3	3.5		
32	1.8	2.7	3.6	2.2	2.7	3.1	3.6	2.7	3.0	3.3	3.6	3.9	3.1	3.4	3.6		
33	1.8	2.8	3.7	2.3	2.8	3.2	2.5	2.8	3.1	3.4	3.7	3.0	3.2	3.5	3.7		
34	1.9	2.9	3.8	2.4	2.9	3.3	2.5	2.9	3.2	3.5	3.8	3.1	3.3	3.6	3.8		
35	2.0	2.9	3.9	2.5	2.9	3.4	2.6	2.9	3.3	3.6	3.9	3.2	3.4	2.9	3.9		
36	2.0	3.0	2.0	2.5	3.0	3.5	2.7	3.0	3.4	3.7	3.0	3.3	3.5	3.0	3.2		
37	2.1	3.1	2.1	2.6	3.1	3.6	2.8	3.1	3.5	3.8	3.1	3.4	3.6	3.1	3.3		
38	2.1	3.2	2.1	2.7	3.2	2.5	2.8	3.2	3.5	3.9	3.2	3.5	3.0	3.2	3.4		
39	2.2	3.3	2.2	2.7	3.3	2.5	2.9	3.3	3.6	3.0	3.3	3.5	3.1	3.3	3.5		
40	2.2	3.4	2.2	2.8	3.4	2.6	3.0	3.4	3.7	3.1	3.4	2.9	3.1	3.4	3.6		

Example
 Part Number sequence: TXBLXXYY:
 • XX = shortest dimension, YY is ≥ XX.
 • One unit of measurement = 25mm of active area, example: TXBL0410 is 100mm x 250mm active area
 • For the TXBL0611, the ULC-2 setting is 1.8A maximum
 Note: Color on chart corresponds to number of ULC channels needed AND number of M12 connectors needed.

- Legend**
- Requires (1) ULC chan (on 1 M12 connector)
 - Requires (2) ULC chan (on 1 M12 connector)
 - Requires (3) ULC chan (on 2 M12 connector)
 - Requires (4) ULC chan (on 2 M12 connector)
 - Requires (5) ULC chan (on 3 M12 connector)

ULC STROBE SETTINGS

- Max overdriving pulse duration= 1000µs (1ms)
- For trigger duty cycles >= 5%
- For ULC-2 external controller, max strobe current per ULC-2 channel is 40A

Single channel ULC Strobing current = TXBLXX * TXBLYY * .028 / User-Desired Trigger Input Duty Cycle / number of colors in light

Examples:

- TXBL0508-W-U and customer desired duty cycle of 20% -- ULC Strobing current = 05 * 08 * .028 / .2 / 1 = 5.6A
- TXCBL0202-R-U and customer desired duty cycle of 5% -- ULC Strobing current = 02 * 02 * .028 / .05 / 1 = 2.2A
- TXCBL1212-B-U and customer desired duty cycle of 10% -- ULC Strobing current = 11 * 12 * .028 / .1 / 1 = 37A
- TXBL1624-RGB-U and customer desired duty cycle of 10% -- ULC Strobing current = 16 * 24 * .028 / .1 / 3 = 35.8A for each of (3) ULC channels

YY



TABLE 6: WEIGHT (KG) FOR ACTIVE AREA WIDTH AND LENGTH

		XX															
TXBL	02	03	04	05	06	07	08	09	10	11	12	13	14	15	16		
02	0.2																
03	0.3	0.3															
04	0.3	0.3	0.4														
05	0.3	0.4	0.4	0.5													
06	0.4	0.4	0.5	0.6	0.6												
07	0.4	0.5	0.5	0.6	0.7	0.8											
08	0.4	0.5	0.6	0.7	0.8	0.8	0.9										
09	0.5	0.6	0.6	0.7	0.8	0.9	1.0	1.1									
10	0.5	0.6	0.7	0.8	0.9	1.0	1.1	1.2	1.3								
11	0.5	0.6	0.7	0.9	1.0	1.1	1.2	1.3	1.4	1.5							
12	0.6	0.7	0.8	0.9	1.0	1.1	1.3	1.4	1.5	1.6	1.7						
13	0.6	0.7	0.8	1.0	1.1	1.2	1.3	1.5	1.6	1.7	1.8	2.0					
14	0.6	0.8	0.9	1.0	1.2	1.3	1.4	1.6	1.7	1.8	1.9	2.1	2.2				
15	0.7	0.8	0.9	1.1	1.2	1.4	1.5	1.6	1.8	1.9	2.1	2.2	2.3	2.5			
16	0.7	0.8	1.0	1.1	1.3	1.4	1.6	1.7	1.9	2.0	2.2	2.3	2.5	2.6	2.8		
17	0.7	0.9	1.1	1.2	1.4	1.5	1.7	1.8	2.0	2.2	2.3	2.5	2.6	2.8	3.0		
18	0.8	0.9	1.1	1.3	1.4	1.6	1.8	1.9	2.1	2.3	2.4	2.6	2.8	2.9	3.1		
19	0.8	1.0	1.2	1.3	1.5	1.7	1.9	2.0	2.2	2.4	2.6	2.7	2.9	3.1	3.3		
20	0.8	1.0	1.2	1.4	1.6	1.8	1.9	2.1	2.3	2.5	2.7	2.9	3.0	3.2	3.4		
21	0.9	1.1	1.3	1.4	1.6	1.8	2.0	2.2	2.4	2.6	2.8	3.0	3.2	3.4	3.5		
22	0.9	1.1	1.3	1.5	1.7	1.9	2.1	2.3	2.5	2.7	2.9	3.1	3.3	3.5	3.7		
23	0.9	1.1	1.4	1.6	1.8	2.0	2.2	2.4	2.6	2.8	3.0	3.2	3.4	3.6	3.8		
24	1.0	1.2	1.4	1.6	1.8	2.0	2.3	2.5	2.7	2.9	3.1	3.3	3.6	3.8	4.0		
25	1.0	1.2	1.5	1.7	1.9	2.1	2.3	2.6	2.8	3.0	3.2	3.5	3.7	3.9	4.1		
26	1.0	1.3	1.5	1.7	2.0	2.2	2.4	2.7	2.9	3.1	3.4	3.6	3.8	4.1	4.3		
27	1.1	1.3	1.6	1.8	2.0	2.3	2.5	2.8	3.0	3.2	3.5	3.7	4.0	4.2	4.4		
28	1.1	1.4	1.6	1.8	2.1	2.3	2.6	2.8	3.1	3.3	3.6	3.8	4.1	4.3	4.6		
29	1.1	1.4	1.6	1.9	2.2	2.4	2.7	2.9	3.2	3.5	3.7	4.0	4.2	4.5	4.7		
30	1.2	1.4	1.7	2.0	2.2	2.5	2.8	3.0	3.3	3.6	3.8	4.1	4.4	4.6	4.9		
31	1.2	1.5	1.7	2.0	2.3	2.6	2.8	3.1	3.4	3.7	3.9	4.2	4.5	4.8	5.0		
32	1.2	1.5	1.8	2.1	2.4	2.6	2.9	3.2	3.5	3.8	4.1	4.3	4.6	4.9	5.2		
33	1.3	1.6	1.8	2.1	2.4	2.7	3.0	3.3	3.6	3.9	4.2	4.5	4.7	5.0	5.3		
34	1.3	1.6	1.9	2.2	2.5	2.8	3.1	3.4	3.7	4.0	4.3	4.6	4.9	5.2	5.5		
35	1.3	1.6	1.9	2.3	2.6	2.9	3.2	3.5	3.8	4.1	4.4	4.7	5.0	5.3	5.6		
36	1.4	1.7	2.0	2.3	2.6	2.9	3.3	3.6	3.9	4.2	4.5	4.8	5.1	5.5	5.8		
37	1.4	1.7	2.0	2.4	2.7	3.0	3.3	3.7	4.0	4.3	4.6	5.0	5.3	5.6	5.9		
38	1.4	1.8	2.1	2.4	2.8	3.1	3.4	3.8	4.1	4.4	4.7	5.1	5.4	5.7	6.1		
39	1.5	1.8	2.1	2.5	2.8	3.2	3.5	3.8	4.2	4.5	4.9	5.2	5.5	5.9	6.2		
40	1.5	1.9	2.2	2.5	2.9	3.2	3.6	3.9	4.3	4.6	5.0	5.3	5.7	6.0	6.4		

Part Number sequence:

TXBLXXYY

- XX = shortest dimension,
- YY is \geq XX

- One unit of measurement = 25mm of active area.

Example Active area/weight:

- TXBL0816 = (08) *25mm X (16) *25mm = 200x400mm, weight is 1.6 kg.

YY



FIGURE 5:
RELATIVE INTENSITY - WHITE SPECTRAL DATA

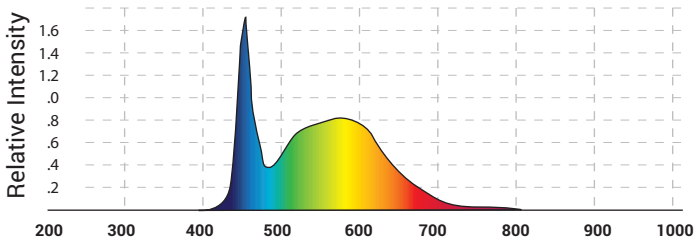

FIGURE 6:
RELATIVE INTENSITY - RED SPECTRAL DATA

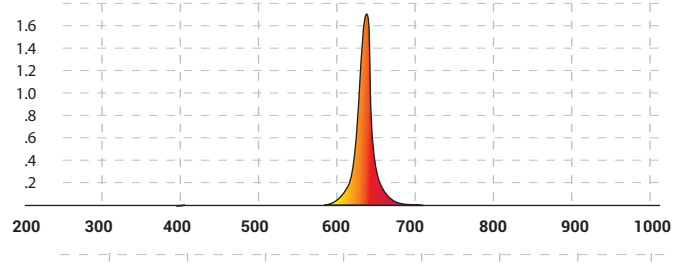

FIGURE 7:
RELATIVE INTENSITY - GREEN SPECTRAL DATA

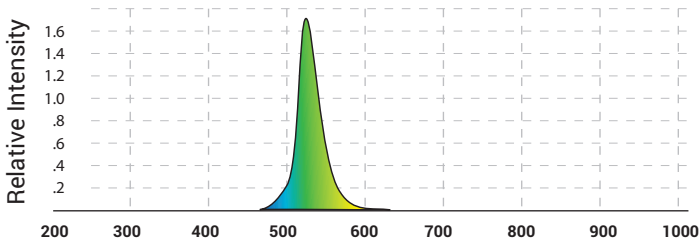

FIGURE 8:
RELATIVE INTENSITY - BLUE SPECTRAL DATA

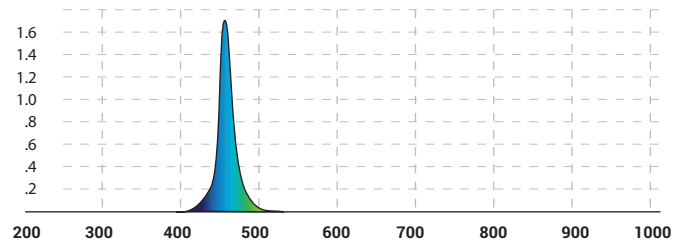

FIGURE 9:
RELATIVE INTENSITY - IR850 SPECTRAL DATA

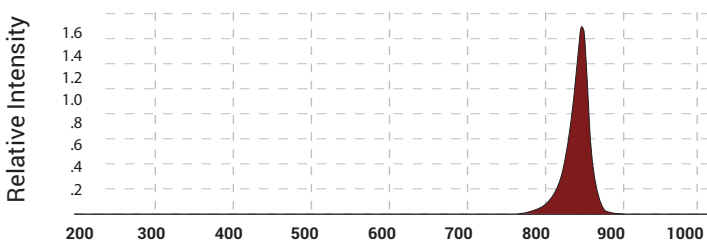

FIGURE 10:
RELATIVE INTENSITY - IR940 SPECTRAL DATA

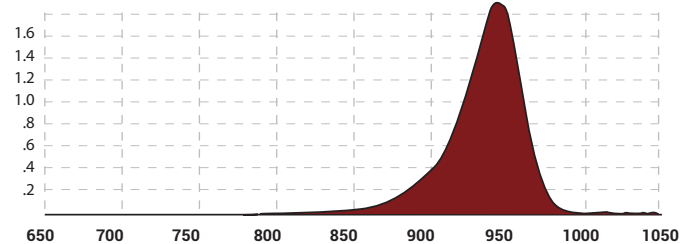

FIGURE 11:
TXBL UNIFORMITY PROFILE



Intensity = 86,000 Lux (263W/m²)

TXBL/ TXCBL Mechanical Drawings



TX Series
Back Light



FIGURE 12: TXBL/ TXCBL DIMENSIONS TOP VIEW

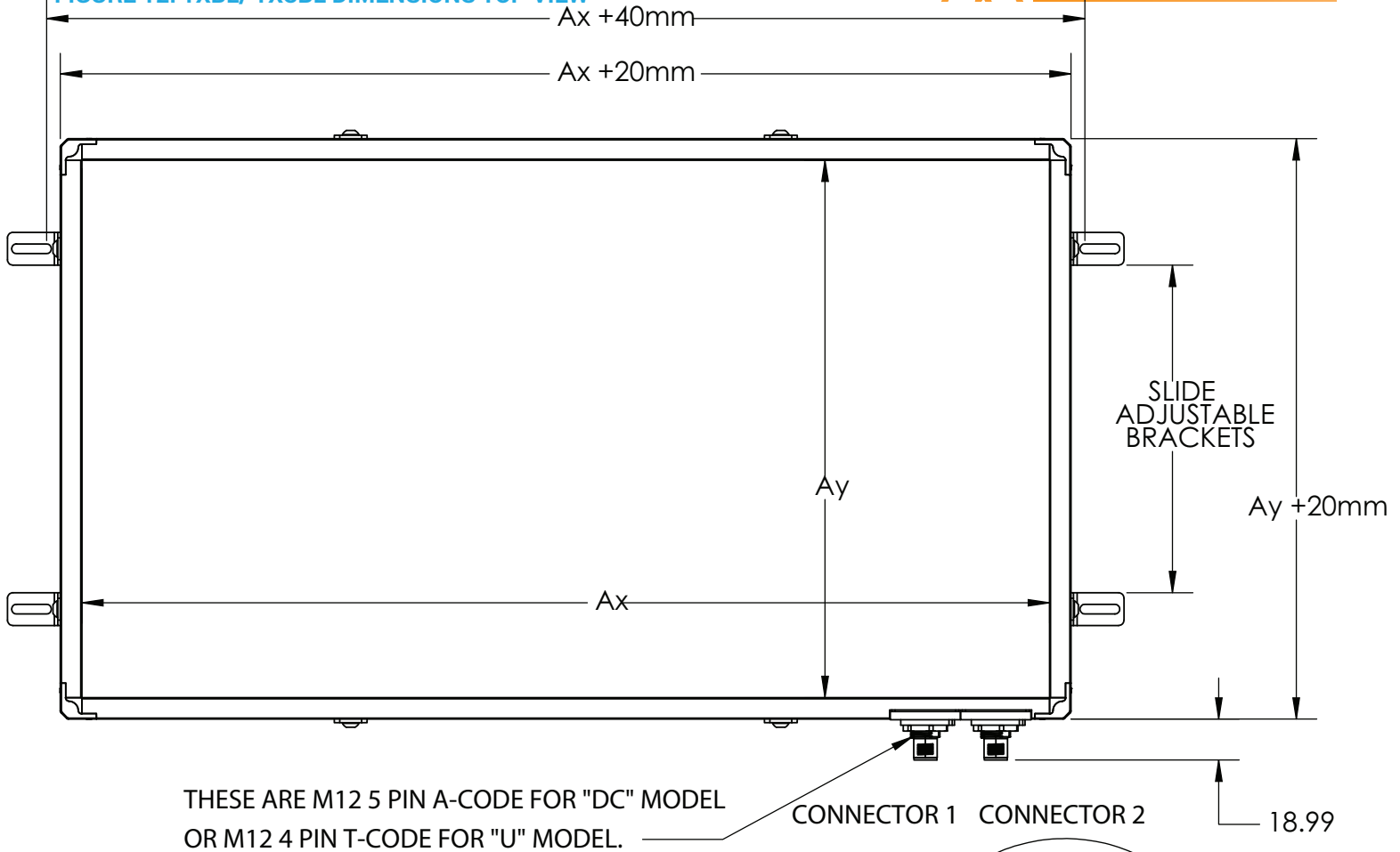
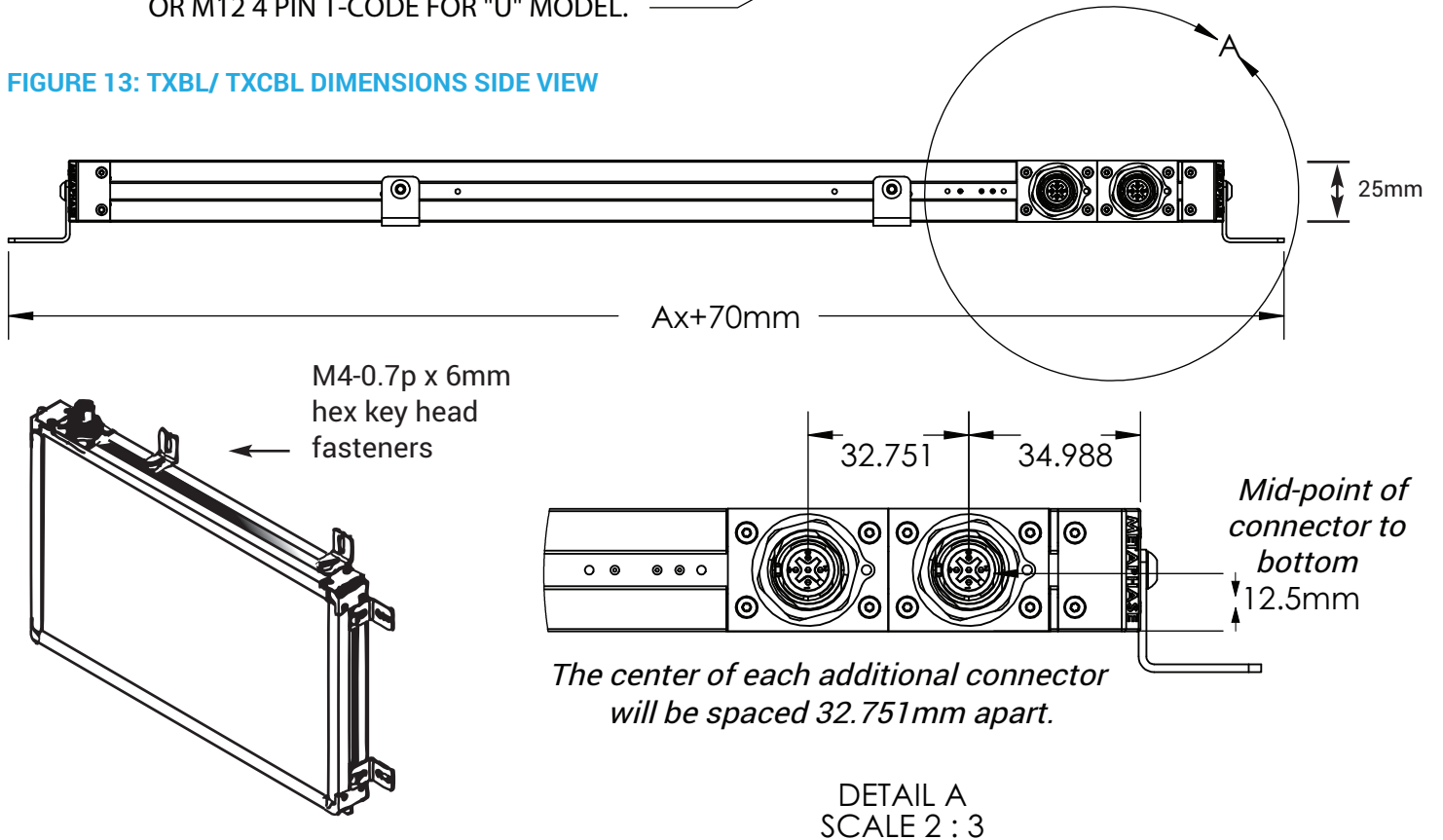

FIGURE 13: TXBL/ TXCBL DIMENSIONS SIDE VIEW





For nearly two decades, Metaphase Technologies has been developing products that implement “The Quality of Light” through engineering and manufacture of cutting-edge LED illuminators for machine vision, military, and specialty lighting applications.

We're proud of our demonstrated expertise engineering flexible lighting solutions that have facilitated integration into thousands of vision systems designs.

Throughout the world, Metaphase clients enjoy the enhanced automation and image capture benefits of our patent-pending breakthroughs in uniform diffuse high brightness and ultra-brightness LED illumination.

First to implement built-in constant current drivers across multiple product lines, Metaphase continues to synergize cutting-edge LED lighting & control technologies that streamline innovation and increases return on investment.

Made in the USA for nearly 30 years, our versatile designs are continuously updated to incorporate the latest advances in LEDs, thermal management, optics, and electronic technologies to meet the challenging needs of today's global automation and scientific marketplace.

Contact us to see how Metaphase can help with your cutting-edge lighting needs.



200 Rittenhouse Circle, West Unit 7, Bristol, PA 19007 USA
[+1-215-639-8699 www.metaphase-tech.com](http://www.metaphase-tech.com)