

Optronis

Make time visible

CamRecord

CL600x2



HIGH-SPEED CAMERA

**Powerful area scan camera
with CameraLink interface**

- > **High sensitive image sensor**
- > **Resolution 1280 x 1024 pixel**
- > **Lookup-Table (LUT) - 10 Bit to 8 Bit**
- > **500 frames/second at full resolution**
- > **Extended dynamic range up to 90 dB**
- > **Base and Full CameraLink interface**
- > **Region of Interest (ROI)**

CamRecord CL600x2

Light sensitive high-speed camera for real-time data acquisition.

Model Overview

Part Number	Description
CL600x2 /M /FM	monochrome, Nikon F-Mount
CL600x2 /M /CM	monochrome, C-Mount
CL600x2 /C /FM	colour, Nikon F-Mount
CL600x2 /C /CM	colour, C-Mount

CameraLink Modes

Base	2 taps / 8 Bit	max. 125 fps
Base	2 taps / 10 Bit	max. 125 fps
Medium	4 taps / 10 Bit	max. 250 fps
Medium	8 taps / 8 Bit	max. 500 fps
Extended Full	10 taps / 8 Bit	max. 500 fps

Connector Pin Assignment

6-pin HR10A-7R-6P Hirose			
Pin 1	Vcc 5 V	Pin 4	Sync OUT
Pin 2	GND	Pin 5	GND
Pin 3	Sync IN	Pin 6	GND

Accessories

Customized power supply
(standard power supply already included)

CameraLink cable

Wide range of C-Mount and F-Mount lenses

Different framegrabbers available on request

Specifications

Resolution	1280 x 1024 pixel
Frame Rate @ Max. Resolution	500 fps
Image Sensor	Progressive Scan CMOS
Exposure Time	1 μ s - 1/Framerate
Active Area	17,92 mm x 14,34 mm
Sensor Diagonal Dimension	22,95 mm
Pixel Size	14 μ m x 14 μ m
A/D Conversion	10 Bit or 8 Bit
Dynamic	60 dB (90 dB optical)
Sensitivity	25 V/lux*s
Shutter	global electronic, >1 μ s exposure time
Synchronization	internal, external
Interface	CameraLink
Video Output	VGA
Supply Voltage	5 VDC
Power Consumption	5 W
Lens Mount	Nikon F-Mount (optional C-Mount)
Weight	250 g
Operating Temperature	0 .. 40°C
Humidity	< 80 % relative, non-condensed
Dimensions	56 mm x 56 mm x 44 mm
Conformity	CE, RoHS
Scope of delivery	Camera CL600x2, power supply, manual

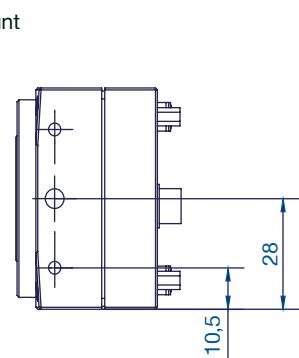
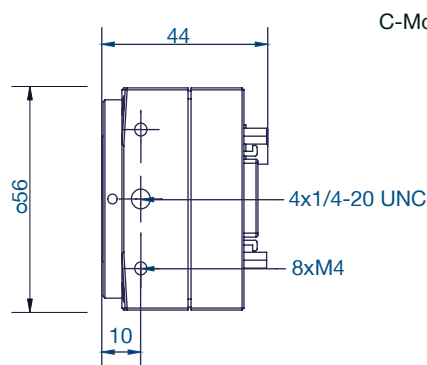
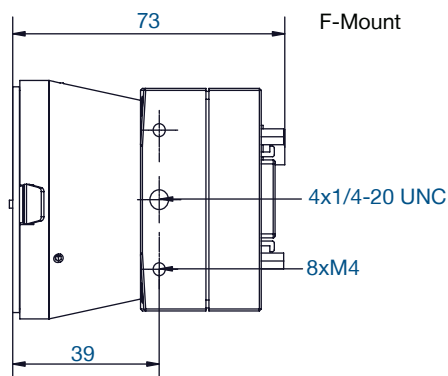

The information given herein is believed to be reliable, however Optronis makes no warranties as to its accuracy or completeness. Data sheet is subject to modifications at any time. 07/2010

Optronis

Make time visible

Optronis GmbH

Honsellstr. 8
77694 Kehl, Germany

Telefon +49 (0) 7851 / 9126-0
Telefax +49 (0) 7851 / 9126-10

E-Mail: info@optronis.com
www.optronis.com