

MACHINE VISION CAMERA

CamPerform

CP70-004-M/C-19000



- METROLOGY
- 2D/3D AOI
- INLINE INSPECTION

- 19789 fps with 192x192 pixels with 12 bit A/D conversion
- New DIN 1.0/2.3 connectors with thread lock
- CoaXPress interface with 25 Gbit/s
- Power and trigger via CoaXPress
- EMVA1288 standard

MODEL OPTIONS

Article number	Description
CP70-004-M-19000	monochrome Camera
CP70-004-C-19000	color Camera
CP70-CM	C-Mount lens adapter
CP70-FM	F-Mount lens adapter
CP70-PTC	Pig tail cable for sync

PERFORMANCE (EXAMPLES)

Resolution (HxV)	Frames/second
192 x 192	19789 fps
192 x 120	30366 fps

STANDARDS

Conformity (documents available on request)	
EMVA1288	Version 3.0
CoaXPress	Version 1.1
GenICam	Fully supported
Shock & Vibration	DIN EN 60721-3-2
ISO	9001:2015
Conformity	CE, RoHS



SPECIFICATIONS

Sensor resolution	192 x 192 Faster frame rates with smaller Y window size;
Frame rate @ max. sensor res.	19789 fps
Image sensor	LUX1310 Global Shutter CMOS
Exposure time	2 µs - 1/Frame rate
Active area	1.27 mm x 1.27 mm
Sensor diagonal dimension	1.8 mm
Pixel size	6.6 µm
A/D conversion	12 Bit
Dynamic	TBD dB
Sensitivity	25 V/lux*s @550 nm
Gain	analog 1x 2x 4x
Saturation capacity (FWC)	17000 e-
SNR	TBD dB
DSNU1288	TBD e-
PRNU1288	TBD %
Non-linearity error	< TBD %
Shutter efficiency	global electronic shutter
Trigger signal	TTL, 3.3 - 5 V, 10 mA, optically isolated
Trigger modes	internal free-run, external, CXP
Interface	CoaXPress (4 Channel, CXP-6) DIN 1.0/2.3 connectors
Power	PoCXP (8.5 Watt)
Lens mount	F-Mount, C-Mount, M42 and custom
Weight	470 g without mount
Dimensions	85 mm x 85 mm x 49.0 mm (3D-Step file on request)
Housing	lightweight anodised aluminium
Scope of delivery	camera and manual

TECHNICAL DRAWING

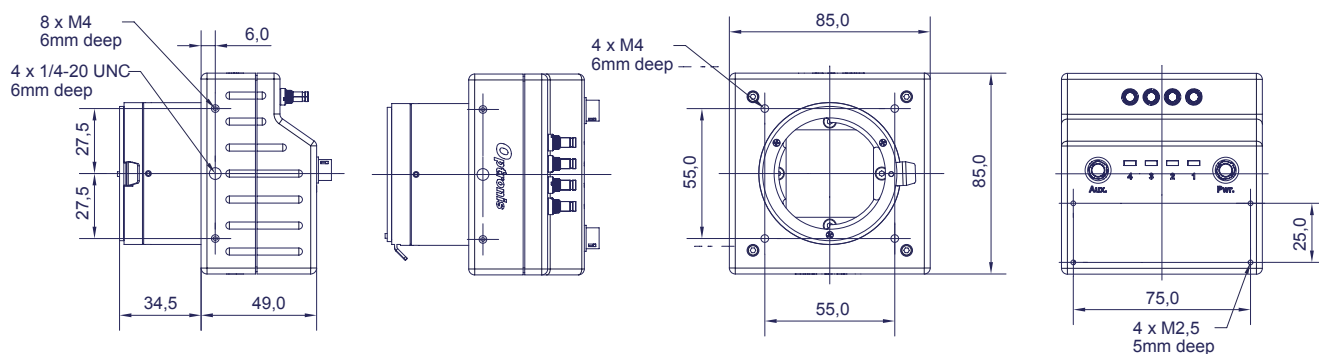

CONTACT INFORMATION

Optronis GmbH
Ludwigstraße 2
77694 Kehl
Germany

Phone: +49 7851 91 26 - 0
Fax: +49 7851 91 26 - 10
info@optronis.com
www.optronis.com