

MACHINE VISION CAMERA

CamPerform

CP70-HD-M/C-900



- METROLOGY
- 2D/3D AOI
- INLINE INSPECTION

- 900 fps with 1920 x 1080 pixels with 8 bit A/D conversion
- New DIN 1.0/2.3 connectors with thread lock
- CoaXPress interface with 25 Gbit/s
- Power and trigger via CoaXPress
- Monochrome and color sensor
- EMVA1288 standard

MODEL OPTIONS

Article number	Description
CP70-HD-M-900	monochrome Camera
CP70-HD-C-900	color Camera
CP70-CM	C-Mount lens adapter
CP70-FM	F-Mount lens adapter
CP70-PTC	Pig tail cable for sync

PERFORMANCE (EXAMPLES)

Resolution (H x V)	Frames / second
1920 x 1080	900 fps
1280 x 720	1319 fps
800 x 600	1553 fps
600 x 480	1888 fps
320 x 256	3162 fps

STANDARDS

Conformity (documents available on request)

EMVA1288	Version 3.0
CoaXPress	Version 1.1
GenICam	Fully supported
Shock & Vibration	DIN EN 60721-3-2
ISO	9001:2015
Conformity	CE, RoHS



SPECIFICATIONS

Sensor resolution	1920 x 1080
	Faster frame rates with smaller Y window size
Frame rate @ max. sensor res.	900 fps
Image sensor	CMV12000 Global Shutter CMOS
Exposure time	38 µs - 1/Framerate
Active area	10.56 mm x 5.94 mm
Sensor diagonal dimension	12.12 mm
Pixel size	5.5 µm
A/D conversion	8 Bit
Dynamic	60 dB
Sensitivity	4.64 V/lux*s @525 nm
Saturation capacity (FWC)	12300 e-
SNR	40.9 dB
DSNU1288	160 e-
PRNU1288	1.3 %
Non-linearity error	<0.5 %
Shutter efficiency	global electronic shutter
Trigger signal	TTL, 3.3 - 5 V, 10 mA, optically isolated
Trigger modes	internal free-run, external, CXP
Interface	CoaXPress (4 Channel, CXP-6) DIN 1.0/2.3 connectors 25 Gbit/s
Power	PoCXP (8.5 Watt)
Lens mount	F-Mount, C-Mount, M42 and custom
Weight	400 g without mount
Dimensions	85 mm x 85 mm x 49.0 mm (3D-Step file on request)
Housing	lightweight anodised aluminium
Scope of delivery	camera and manual

TECHNICAL DRAWING

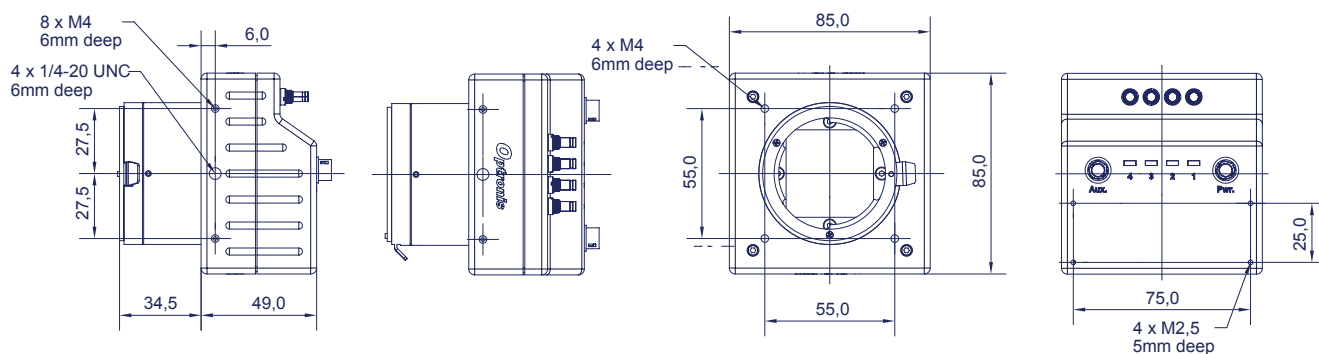

CONTACT INFORMATION

Optronis GmbH
Ludwigstraße 2
77694 Kehl
Germany

Phone: +49 7851 91 26 - 0
Fax: +49 7851 91 26 - 10
info@optronis.com
www.optronis.com