

MACHINE VISION CAMERA

CamPerform

CP90-25P-M/C-72



- METROLOGY
- 2D/3D AOI
- INLINE INSPECTION

- On Semi Python sensor with 5120x5120 pixels @ 72 fps
- New DIN 1.0/2.3 connectors with thread lock
- CoaXPress interface with 25 Gbit/s
- Power and trigger via CoaXPress
- Monochrome and color sensor
- EMVA1288 standard

MODEL OPTIONS

Article number	Description
CP90-25P-M-72	monochrome Camera
CP90-25P-C-72	color Camera
CP90-CM	C-Mount lens adapter
CP90-FM	F-Mount lens adapter
CP90-PTC	Pig tail cable for sync

PERFORMANCE (EXAMPLES)

Resolution (H x V)	Frames / second
5120 x 5120	72 fps
4000 x 2000	231 fps
3000 x 2000	284 fps
1920 x 1080	506 fps
1280 x 720	729 fps

STANDARDS

Conformity (documents available on request)

EMVA1288	Version 3.0
CoaXPress	Version 1.1
GenICam	Fully supported
Shock & Vibration	DIN EN 60721-3-2
ISO	9001:2015
Conformity	CE, RoHS



SPECIFICATIONS

Sensor resolution	5120 x 5120 faster frame rates with smaller X,Y window size
Frame rate @ max. sensor res.	72 fps
Image sensor	Pyhton25k Global Shutter CMOS
Exposure time	100 µs - 1/Frame rate
Active area	23.04 mm x 23.04 mm
Sensor diagonal dimension	32.58 mm
Pixel size	4.5 µm
A/D conversion	10 Bit, 8 Bit (LUT optional)
Dynamic	59 dB
Sensitivity	5.8 V/lux*s @555 nm
Saturation capacity (FWC)	12000 e-
SNR	41 dB
DSNU1288	TBD e-
PRNU1288	TBD %
Non-linearity error	<TBD %
Shutter efficiency	global electronic shutter
Trigger signal	TTL, 3.3 - 5 V, 10 mA, optically isolated
Trigger modes	internal free-run, external, CXP
Interface	CoaXPress (4 Channel, CXP-6) DIN 1.0/2.3 connectors 25 Gbit/s
Power	PoCXP (TBD Watt)
Lens mount	F-Mount, C-Mount, M42 and custom
Weight	400 g without mount
Dimensions	85 mm x 85 mm x 62.5 mm (3D-Step file on request)
Housing	lightweight anodised aluminium
Scope of delivery	camera and manual

TECHNICAL DRAWING

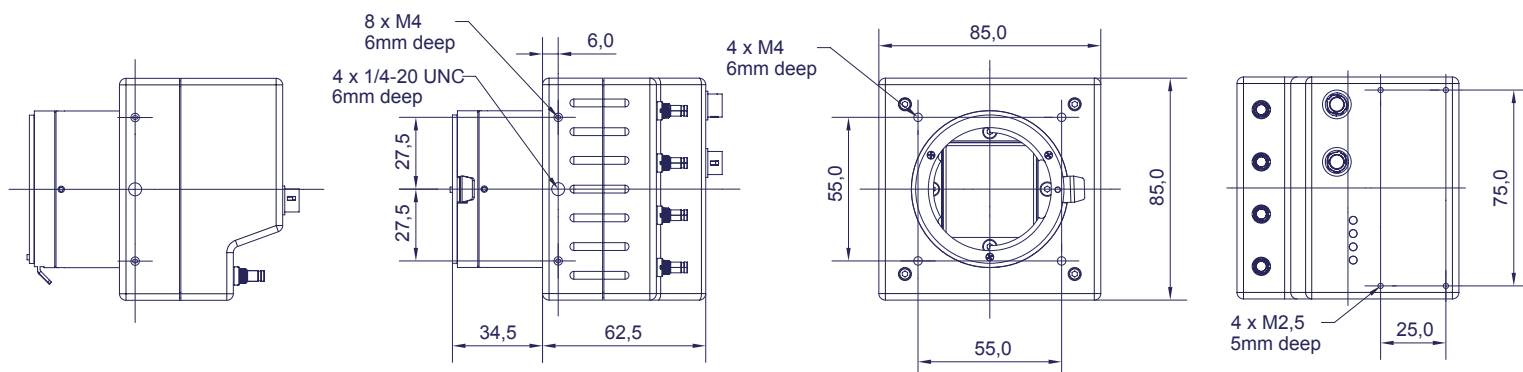

CONTACT INFORMATION

Optronis GmbH
Ludwigstraße 2
77694 Kehl
Germany

Phone: +49 7851 91 26 - 0
Fax: +49 7851 91 26 - 10
info@optronis.com
www.optronis.com