VC-12MX2-M/C 330

THE FASTEST SPEED & HIGH RESOLUTION CMOS DIGITAL CAMERA
WITH COAXPRESS INTERFACE



The VC-12MX2-330 camera, the latest member of the industry proven VC series, is based on the latest CMOS global shutter imager. Equipped with the Vieworks' innovative technologies proved by the world's top FPD manufacturers, this camera offers not only the highest frame rate but also highly uniformed images. This camera supports 12 megapixel resolutions with frame rate up to 330 fps (CoaXPress - 8 Channels). Its CoaXPress interface supports transmitting image data at up to 25 Gbps using four coaxial cables and up to 50 Gbps using eight cables.

Featured with high quality image uniformity and high resolution, this camera is ideal for wide range of demanding applications including FPD, PCB and semiconductor inspections.

VC-12MX2-M/C 330

THE FASTEST SPEED & HIGH RESOLUTION CMOS DIGITAL CAMERA WITH COAXPRESS INTERFACE

Main Features

- * 12 Megapixels Resolution
- * High-Speed Progressive Scan CMOS Imager
- * Global Shutter CMOS Technology
- * CoaXPress Interface up to 330 fps at 50 Gbps using 8 CH
- * Flat Field Correction
- * Low Noise with Optimized Heat Treatment

Applications

- * FPD and Electronics Inspection
- * Semiconductor Inspection
- * Research and Scientific Imaging
- * Document / Film Scanning

Specifications

Model	VC-12MX2-M/C 330	
Resolution (H × V)	4096 × 3072	
Sensor	CMOSIS CMV 12000	
Sensor Size (Optical Format)	22.5 mm × 16.9 mm (Diagonal: 28.14 mm, APS-like)	
Sensor Type	High Speed CMOS Image Sensor	
Pixel Size	5.5 μm × 5.5 μm	
Interface	CoaXPress	
Max. Frame Rate	4 CH: 188 fps @ 6.25 Gbps 8 CH: 330 fps @ 6.25 Gbps	
Exposure Time (1 μs step)	16 μs – 60 s	
Partial Scan (Max. Speed)	1114 fps at 500 Lines	
Pixel Data Format	8 bit	
Electronic Shutter	Global Shutter	
Gain Control	×1 ~ ×4 (0 ~ 12 dB)	
Black Level Control	0 – 16 LSB at 8 bit	
Exposure Mode	Free-Run, Timed, Trigger Width	
Dynamic Range	54 dB	
Dimension / Weight	90 mm × 90 mm × 114 mm, 745 g (F-mount)	
Temperature	Operating: 0°C ~ 40°C (Housing: 10°C ~ 50°C), Storage: -40°C ~ 70°C	
Lens Mount	F-mount	
Power	Adapter	8 ~ 30 V DC, Typ. 18 W
	PoCXP	24 V DC, Minimum of four PoCXP cables required
Compliance	CE, FCC, KC	
API SDK	Viewworks Imaging Solution 7.X	

VC-12MX2-M/C 330

THE FASTEST SPEED & HIGH RESOLUTION CMOS DIGITAL CAMERA WITH COAXPRESS INTERFACE

Quantum Efficiency Curves

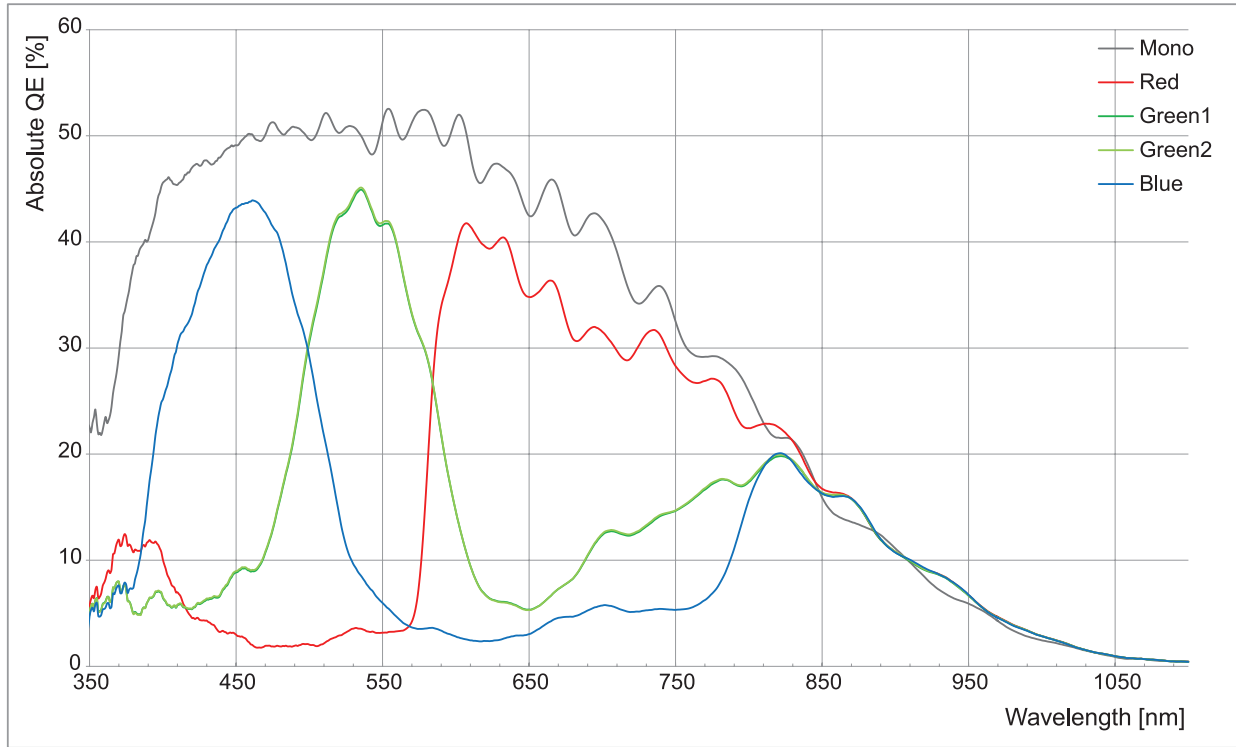

Ordering Scheme

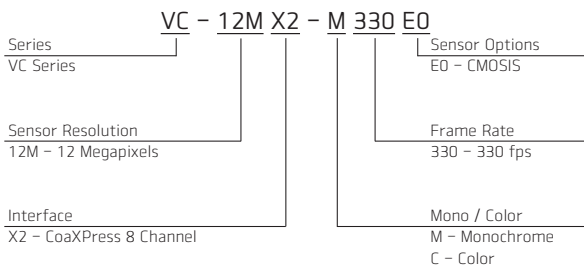

Connector Specification

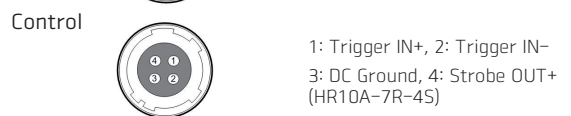
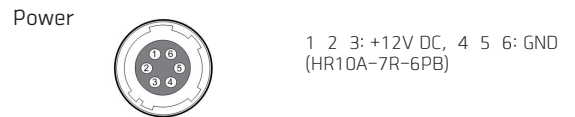

Data Transfer/Communications

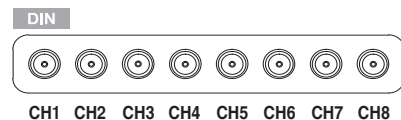

CH1: Master Connection (75 Ω, DIN 1.0/2.3)

Connectors on camera body

VC-12MX2-M/C 330

THE FASTEST SPEED & HIGH RESOLUTION CMOS DIGITAL CAMERA WITH COAXPRESS INTERFACE

Mechanical Dimensions

Unit: mm

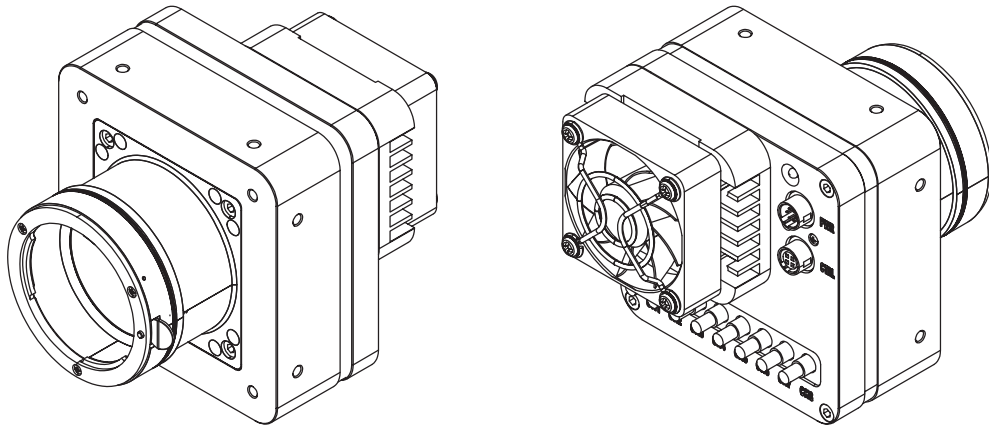
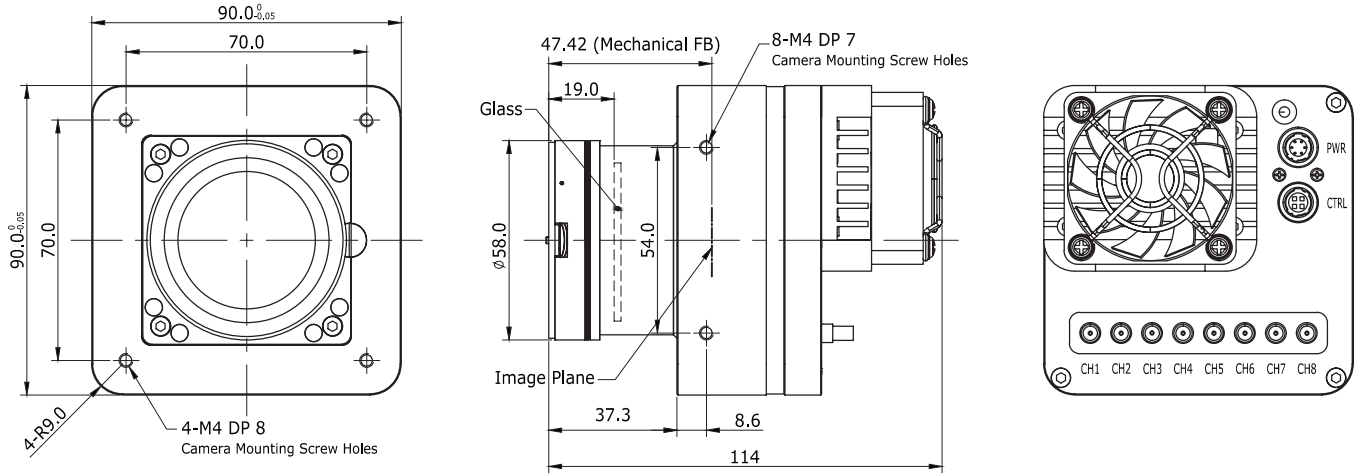

For more information please contact local distributor or visit our website at <http://www.vieworks.com>.

Reproduction in whole or in part without written permission is prohibited. Vieworks Co., Ltd. is not responsible for any technical or typographical errors and reserves the right to make changes to products, specifications and documentation without prior notice.

D-17-001

VIEWORKS

41-3, Burim-ro 170 beon-gil, Dongan-gu, Anyang-si, Gyeonggi-do, 14055 Republic of Korea
tel +82-70-7011-6161 fax +82-31-386-8631 e-mail sales@vieworks.com