

# RTxxx LED Lighting Controllers

Issue 015



User manual

## Copyright and disclaimer notice

Except as prohibited by law:

All hardware, software and documentation is provided on an 'as is' basis. This information is for guidance only. Installers must perform their own risk assessment specific to each installation.

It is essential that the user ensures that the operation of the product is suitable for their application.

The user must ensure that incorrect functioning of this equipment cannot cause any dangerous situation or significant financial loss to occur.

Deliberate acts of endangerment and vandalism are not covered by this document and must be considered by the installer.

While care has been taken in the preparation of this document Gardasoft Vision Ltd will not accept any liability for consequential loss of any kind except those required by law.

All trademarks acknowledged. This document is Copyright 2020 Gardasoft Vision Ltd.

### **EC conformity declaration**

The EC Certificate of Conformity is available from Gardasoft Vision Ltd on request.

Issue status of this document: Issue v015 - August 2020

---

# Contents

<b>1</b>	<b>Getting started</b>	<b>5</b>
1.1	Summary of features	5
<b>2</b>	<b>Safety</b>	<b>7</b>
2.1	Heat	7
2.2	Electrical	7
2.3	General	9
2.4	Installation guidance (disclaimer)	9
<b>3</b>	<b>Sicherheit</b>	<b>10</b>
3.1	Wärme	10
3.2	Elektrik	10
3.3	Allgemein	12
3.4	Installationsanleitung (Haftungsausschluss)	12
<b>4</b>	<b>Sécurité</b>	<b>13</b>
4.1	Chaleur	13
4.2	Électricité	13
4.3	Généralités	15
4.4	Guide d'installation (clause de non-responsabilité)	15
<b>5</b>	<b>Mounting the RTxxx</b>	<b>16</b>
5.1	Environmental considerations	16
5.2	Electrostatic discharge	18
<b>6</b>	<b>Connections</b>	<b>19</b>
6.1	Power supply	19
6.2	Lighting output	19
6.3	Trigger inputs	22
6.4	12V Power output	23
6.5	Ethernet connection	23
6.6	Serial connection	23
6.7	Connectors	24
<b>7</b>	<b>General description</b>	<b>25</b>
7.1	Output modes	25
7.1.1	<i>Continuous output, switched output, selected output</i>	25
7.2	Pulsed output	26
7.3	Fault detection	27
7.4	Light auto-sensing	27
7.5	Light characterisation	28
7.6	Current adjust	28
7.7	Cold start	29
<b>8</b>	<b>Lighting setup</b>	<b>30</b>
<b>9</b>	<b>Front panel configuration (RT200)</b>	<b>31</b>
9.1	Startup	31
9.2	Setting the light rating	32
9.3	Setting up continuous output	33
9.4	Setting up switched output	35
9.5	Setting up selected output	37
9.6	Setting up pulsed operation	39
9.7	Setting time periods	42

9.8	Setting the internal trigger timer	45
9.9	Using the key lock	46
9.10	Viewing the trigger status	48
9.11	Viewing the output current	48
<b>10</b>	<b>Ethernet communication(RT220, RT420, RT820F)</b>	<b>50</b>
10.1	Connection	50
10.2	IP Address	50
10.2.1	<i>DHCP</i>	51
10.2.2	<i>Fixed IP address</i>	52
10.3	Automatic sensing	52
<b>11</b>	<b>Webpage configuration (RT220, RT420, RT820F)</b>	<b>53</b>
11.1	Main page	53
11.2	Configuration page	54
11.3	General setup page	55
<b>12</b>	<b>Command configuration</b>	<b>56</b>
12.1	Ethernet configuration(RT220, RT420, RT820F)	56
12.2	RS232 configuration(RT260, RT460, RT860F)	56
12.3	Command structure	56
12.3.1	<i>General commands</i>	57
12.3.2	<i>Lighting channel commands</i>	60
12.3.3	<i>Command summary</i>	63
<b>13</b>	<b>Reference information</b>	<b>65</b>
13.1	Specification	65
13.2	Restrictions	66
13.3	Error codes	67
13.4	Fatal error codes	68
13.5	Event codes	68

---

# 1 Getting started

This user manual describes the setting up and operation of the RTxxx range of LED lighting controllers.

Read Section Safety (or Section 3, Sicherheit, or Section 4, Sécurité) and Section 13.1, Specification, and check the RTxx controller fulfils your requirements.

Mount the RTxxx as described in Section 5, Mounting the RTxxx and connect the RTxxx up to a power supply as described in Section 6, Connections. The RT200 shows a two alternating lines on it's display to indicate it is working properly.

Read Section 8, Lighting setup. Enter the current or voltage rating of the lights and then connect the lights. Set up the RTxxx for the desired operation as described in the configuration sections; Section 9, Front panel configuration (RT200), Section 11, Webpage configuration (RT220, RT420, RT820F), and Section 12, Command configuration.

Visit [www.gardasoft.com](http://www.gardasoft.com) for application notes on this product. There is also a Support page which has information on troubleshooting problems.

## 1.1 Summary of features

Throughout this manual, references to the RTxxx refer to all variants in the RTxxx range unless otherwise stated. The convention for the product number is:

**RTcd0-vv**

**RTcd0F-vv**

where:

- |           |   |
|-----------|---|
| <b>c</b>  | Number of channels: 2, 4, 8                                   |
| <b>d</b>  | Configuration option: 0 = Pushbutton, 2 = Ethernet, 6 = RS232 |
| <b>F</b>  | Option for fast pulsing. All RT8xx models are fast pulsing.   |
| <b>vv</b> | Maximum pulse current in amps: 2, 20                          |

The table below lists the features on each model:

	<b>Number of channels</b>	<b>Pushbutton setup</b>	<b>Ethernet setup</b>	<b>RS232 setup</b>	<b>Fast pulsing</b>
RT200	2	Yes	No	No	No
RT220	2	No	Yes	No	No
RT260	2	No	No	Yes	No
RT200F	2	Yes	No	Yes	Yes
RT220F	2	No	Yes	No	Yes
RT260F	2	No	No	Yes	Yes
RT420	4	No	Yes	No	No
RT460	4	No	No	Yes	No
RT420F	4	No	Yes	No	Yes
RT460F	4	No	No	Yes	Yes
RT820F	8	No	Yes	No	Yes
RT860F	8	No	No	Yes	Yes

## 2 Safety

Read this before using the RTxxx. Always observe the following safety precautions. If in doubt, contact Gardasoft Vision Ltd. The following symbols are used in this guide:



**Warning:** Read the instructions to understand the possible hazards.



**Warning:** Surface may get hot.



**Warning:** Possible hazardous voltage.

Where these symbols appear in the manual, refer to the text for the precautions to be taken.

### 2.1 Heat



Ensure the RTxxx is mounted correctly (see [Section 5, Mounting the RTxxx](#)), and that you do not exceed any of the ratings for the unit (see [Section 1.1, Specifications and ratings](#))

At its maximum ratings, the RTxxx's enclosure can exceed 65°C which is sufficient to cause a burn if touched. Place in a position where personnel cannot accidentally touch it and ensure there is a free flow of air around the unit.

### 2.2 Electrical



The RTxxx produces high energy pulses. Take care to connect the outputs correctly and protect the output wiring and load from any short-circuits. When switched off, energy remains stored in the RTxxx for about 15 seconds.

The RTxxx does not have complete electrical isolation of inputs (including triggering and communications ports) and outputs, therefore, please observe the following guidance:

- » Computer equipment that is connected to the communication or trigger ports must be internally powered or separated from mains electricity by double insulation/reinforced isolation or be approved to IEC 60950-1 standard. All other equipment connected to the triggers or other ports must also have double insulation/reinforced isolation protection from the mains supply.

- » The Power Supply Unit (PSU) used to energise the RTxxx must provide double insulation/reinforced isolation from mains electricity and protected against short circuits and overloads. We recommend using a PSU that limits its output current to the appropriate rating of the controller by design, by setting the current limit on the supply (if possible), or through over current protection. The PSU should be approved to either IEC 60950-1, IEC 60335-1, IEC 61010-1, IEC61558-1,-2,-16. The PSU may also be approved to equivalent or superior safety standards.
- » Any energised conductors derived from mains electricity must also have Safety Extra Low Voltage (SELV) output. Refer to [Section 13, Reference information](#) for allowable voltage limits.
- » At maximum ratings the temperature of the enclosure can exceed 65°C. Therefore, either all cabling must be rated to at least 100°C, or all cabling must be additionally insulated by an appropriately rated heat resistant sleeve or prevented from touching the metal enclosure of the controller, or its heatsink where fitted.
- » Power supply cabling to the controller must be rated to at least 5A or 10A (RT8xxF).
- » The cabling from the channel output to the load must be rated higher than the maximum channel output current.
- » If the controller is set up incorrectly, or in the event of failure, the energy provided by the power supply to the controller may become directly connected to any or all output channels. You must consider this during installation, and if necessary, provide adequate protection.
- » The DC power supply to controller must be externally fused to 5A or 10A (RT8xxF) using a slow blow fuse (T5AH, 50V or T10A, 50V).
- » The installer must provide a clearly marked, nearby and easily accessible switch as part of the installation to allow the controller to be disconnected from its energy source on both power conductors.
- » Transients caused by inductive loads must be suppressed externally to the RTxxx.

**Warning:** This is a Class A product. Its use in residential areas may cause radio interference, and such use should be avoided unless special measures are taken by the user to restrict emissions to a level that allows the reception of broadcast transmissions.



## 2.3 General



The RTxxx must not be used in an application where its failure could be a danger to personal health or damage to other equipment.

If the equipment is used in a manner not specified by the manufacturer, the protection provided by the equipment may be impaired.

## 2.4 Installation guidance (disclaimer)

This information is for guidance only. Installers must perform their own risk assessment specific to each installation. While Gardasoft Vision Ltd has taken every care in the preparation of this advice, Gardasoft Vision Ltd accept no liability for damages of any kind except those required by law.

Deliberate acts of endangerment and vandalism are not covered by this document and must be considered by the installer.

## 3 Sicherheit

Bitte lesen Sie vor Verwendung des RTxxx diese Informationen. Beachten Sie immer die folgenden Sicherheitshinweise. Wenden Sie sich im Zweifelsfall an Ihren Händler oder Gardasoft Vision. Die folgenden Symbole haben die folgende Bedeutung:



**Warnung:** Lesen Sie die Hinweise, um eine mögliche Gefahr zu verstehen.



**Warnung:** Oberfläche kann heiß werden.



**Warnung:** Mögliche gefährliche Spannung.

Wenn diese Symbole in der Anleitung auftauchen, enthält der Text Hinweise zu den zu ergreifenden Vorsichtsmaßnahmen.

### 3.1 Wärme



Stellen Sie sicher, dass der RTxxx korrekt montiert ist (siehe [Section 5, Mounting the RTxxx](#)) und dass Sie die Grenzwerte für das Gerät nicht überschreiten (siehe [Section 13, Reference information](#)).

Bei den maximalen Grenzwerten kann das Gehäuse des RTxxx 65°C überschreiten, was ausreichend ist um bei einer Berührung zu Verbrennungen zu führen. Positionieren Sie das Gerät so, dass eine versehentliche Berührung durch das Personal ausgeschlossen ist und stellen Sie sicher, dass Luft frei um das Gerät zirkulieren kann.

### 3.2 Elektrik



Das RTxxx erzeugt Impulse mit hoher Energie. Achten Sie darauf, die Ausgänge korrekt anzuschließen und schützen Sie die Ausgangsverkabelung und Last gegen Kurzschlüsse. Beim Ausschalten bleibt Energie für etwa 15 Sekunden im RTxxx gespeichert.

Das RTxxx verfügt über keine vollständige elektrische Trennung der Eingänge (einschließlich Trigger- und Kommunikationsports) und Ausgänge. Beachten Sie daher unbedingt die folgenden Hinweise:

- » Computergeräte, die an die Kommunikations- oder Trigger-Ports angeschlossen sind, müssen über eine interne Stromversorgung verfügen oder vom Stromnetz durch eine doppelte Isolierung/verstärkte Isolierung getrennt sein oder nach dem

Standard IEC 60950-1 zugelassen sein. Alle anderen Geräte, die an die Trigger- oder andere Ports angeschlossen sind, müssen ebenfalls durch eine doppelte Isolierung/verstärkte Isolierung vom Stromnetz getrennt sein.

- » Das Netzgerät, das zur Stromversorgung des RTxxx dient, muss durch eine doppelte Isolierung/verstärkte Isolierung von der Stromversorgung getrennt sein und gegen Kurzschlüsse und Überlastungen geschützt sein. Wir empfehlen die Verwendung eines Netzgeräts, das den Ausgangsstrom durch konstruktive Maßnahmen, durch Einstellen der Stromgrenze an der Versorgung (wenn möglich) oder durch einen Überstromschutz auf den geeigneten Nennstrom der Steuerung begrenzt. Das Netzgerät muss nach IEC 60950-1, IEC 60335-1, IEC 61010-1 oder IEC61558-1,-2,-16 zugelassen sein. Das Netzgerät kann auch nach gleichwertigen oder höheren Standards zugelassen sein.
- » Alle stromführenden Leiter, die vom Stromnetz abgeleitet sind, müssen ebenfalls Sicherheitskleinspannung (SELV) am Ausgang erzeugen. Hinweise zu den zulässigen Spannungsgrenzwerten finden Sie im [Section 13, Reference information](#).
- » Bei den maximalen Grenzwerten kann die Temperatur des Gehäuses 65°C überschreiten. Daher muss entweder die gesamte Verkabelung für mindestens 100°C bemessen sein oder die gesamte Verkabelung muss zusätzlich mit einer angemessen dimensionierten wärmebeständigen Tülle isoliert sein oder gegen Kontakt mit dem Metallgehäuse der Steuerung oder deren Kühlkörper, sofern angebracht, geschützt sein.
- » Die Verkabelung der Stromversorgung zur Steuerung muss für mindestens 5A (oder 10A für RT8xxF) bemessen sein.
- » Die Verkabelung vom Kanalausgang zur Last muss höher als der maximale Kanalausgangsstrom dimensioniert sein.
- » Wenn die Steuerung falsch eingerichtet ist oder im Fall eines Fehlers, kann es vorkommen, dass die von der Stromversorgung an die Steuerung abgegebene Energie direkt mit einem oder allen Ausgangskanälen verbunden wird. Sie müssen dies bei der Installation berücksichtigen und gegebenenfalls für einen geeigneten Schutz sorgen.
- » Die Gleichstromversorgung der Steuerung muss extern durch eine träge Sicherung (T5AH, 50V, oder T10A, 50V für RT8xxF) bis 5A oder 10A gesichert sein.

- » Der Installationstechniker muss einen deutlich gekennzeichneten, leicht zugänglichen Schalter als Teil der Installation in der Nähe vorsehen, mit dem die Steuerung an beiden Stromleitern von ihrer Stromquelle getrennt werden kann.
- » Durch induktive Lasten verursachte Einschaltstöße zum RTxxx müssen extern unterdrückt werden.

**Warnung:** Es handelt sich hierbei um ein Produkt der Klasse A. Die Verwendung in Wohngebieten kann zu Funkstörungen führen und eine solche Verwendung sollte vermieden werden, es sei denn besondere Maßnahmen werden vom Anwender ergriffen, um die Emissionen auf ein Niveau zu begrenzen, das den Empfang von Rundfunkübertragungen ermöglicht.

### 3.3 Allgemein



Das RTxxx darf nicht in Anwendungen eingesetzt werden, bei denen es durch einen Ausfall des Geräts zu einer Gefahr für die Gesundheit von Personen oder zur Beschädigung anderer Geräte kommen könnte. Wenn das Gerät in einer anderen als der vom Hersteller vorgesehenen Weise verwendet wird, kann die Schutzvorrichtung des Geräts beeinträchtigt werden.

### 3.4 Installationsanleitung (Haftungsausschluss)

Diese Informationen dienen nur zur Orientierung. Installationstechniker müssen ihre eigene spezifische Risikobewertung für die jeweilige Installation durchführen. Auch wenn Gardasoft Vision Ltd diese Empfehlung mit größter Sorgfalt erstellt hat, übernimmt Gardasoft Vision Ltd keine Haftung für Schäden jeglicher Art, außer in dem gesetzlich erforderlichen Maße. Vorsätzliche Gefährdungs- oder Zerstörungshandlungen werden in diesem Dokument nicht behandelt und müssen vom Installationstechniker berücksichtigt werden.

## 4 Sécurité

Lisez ce document avant d'utiliser le RTxxx. Respectez les mesures de sécurité suivantes en toutes circonstances. En cas de doute, contactez votre distributeur ou Gardasoft Vision. Les symboles ci-dessous auront la signification suivante:



**Attention:** Lisez les instructions pour comprendre quels sont les risques éventuels.



**Attention:** La surface peut devenir chaude.



**Attention:** Risque d'électrocution.

Lorsque ces symboles apparaissent dans le manuel, reportez-vous aux consignes pour connaître les précautions à prendre.

### 4.1 Chaleur



Veillez à ce que le RTxxx soit monté correctement (voir [Section 5, Mounting the RTxxx](#)) et à ne dépasser aucune valeur nominale pour l'unité (voir [Section 13, Reference information](#)).

Lorsqu'il atteint ses valeurs nominales maximales, le boîtier RTxxx peut dépasser les 65°C, ce qui est suffisant pour provoquer des brûlures en cas de contact. Placez l'appareil à un endroit où le personnel ne risque pas de le toucher par accident et veillez à ce que l'air circule librement autour de l'unité.

### 4.2 Électricité



Le RTxxx produit des impulsions d'énergie élevées. Veillez à bien raccorder les sorties et à ce que les câbles de sortie et la charge soient à l'abri de tout court-circuit. Lorsque le RTxxx est éteint, de l'énergie résiduelle reste dans l'appareil pendant environ 15 secondes.

Le RTxxx ne possède pas d'isolation électrique complète des entrées (notamment des ports de déclenchement et de communication) et des sorties. Par conséquent, respectez les consignes suivantes :

- » L'équipement informatique connecté aux ports de communication et de déclenchement doit être alimenté en interne ou séparé de l'alimentation secteur par une isolation double/renforcée, ou être approuvé selon la norme CEI 60950-1. Tous les autres équipements

branchés aux déclencheurs ou à d'autres ports doivent aussi posséder une isolation double/renforcée pour être protégés de l'alimentation secteur.

- » Le boîtier d'alimentation utilisé pour mettre sous tension le RTxxx doit fournir une isolation double/renforcée pour isoler le RTxxx de l'alimentation secteur, et le protéger des courts-circuits et des surcharges. Nous recommandons d'utiliser un boîtier d'alimentation qui limite le courant de sortie de l'appareil à la valeur nominale appropriée du contrôleur, en réglant la limite de courant sur l'alimentation (si possible) ou via la protection contre les surcharges. Le boîtier d'alimentation doit être approuvé selon la norme CEI 60950-1, CEI 60335-1, CEI 61010-1 ou CEI 61558-1,-2,-16. Le boîtier d'alimentation peut aussi être approuvé selon des normes de sécurité équivalentes ou supérieures.
- » Tous les conducteurs sous tension dérivés depuis l'alimentation secteur doivent aussi posséder une sortie à tension de sécurité extra-basse. Se reporter à la [Section 13, Reference information](#) pour les limites de tension autorisées.
- » Lorsqu'il atteint ses valeurs nominales maximales, le boîtier du RTxxx peut dépasser les 65°C. Par conséquent, tout le câblage doit soit avoir une capacité minimale de 100°C, soit être en plus isolé par une gaine suffisamment résistante à la chaleur, soit ne pas toucher le boîtier en métal du contrôleur ou son dissipateur thermique s'il est installé.
- » Le câblage d'alimentation vers le contrôleur doit avoir une capacité minimale de 5A (ou 10A pour RT8xxF).
- » Le câblage reliant la sortie de la chaîne à la charge doit avoir une capacité supérieure au courant de sortie maximal de la chaîne.
- » Si le contrôleur est mal réglé ou en cas de panne, l'énergie fournie par l'alimentation au contrôleur peut devenir directement connectée à n'importe quelle chaîne de sortie ou à toutes les chaînes de sortie. Vous devez prendre en compte ce paramètre durant l'installation et si nécessaire, fournir une protection adéquate.
- » L'alimentation en courant continu vers le contrôleur doit être protégée par un fusible 5A (ou 10A pour RT8xxF) en externe, plus précisément un fusible à action retardée (T5AH, 50V ou T10A, 50V).
- » Dans le cadre de l'installation, l'installateur doit fournir un interrupteur clairement marqué, qui soit à proximité et facilement accessible, pour permettre au contrôleur d'être déconnecté de sa source d'énergie sur les conducteurs d'alimentation.

- » Les coupures causées par des charges inductives doivent être supprimées de manière externe vers le RTxxx.

**Attention:** Il s'agit d'un produit de classe A. Son utilisation en zone résidentielle peut causer des interférences radio. Ce type d'utilisation doit être évité, sauf si des mesures particulières sont prises par l'utilisateur pour restreindre les émissions à un niveau qui permet la réception des transmissions diffusées.

### 4.3 Généralités



Le RTxxx ne doit pas être utilisé dans une application où la santé des personnes et l'intégrité des équipements seraient mises en danger s'il venait à tomber en panne.

Si l'équipement est utilisé autrement qu'aux fins prévues par le fabricant, la protection offerte par l'équipement pourrait en être altérée.

### 4.4 Guide d'installation (clause de non-responsabilité)

Ces informations sont seulement à titre indicatif. Les installateurs doivent effectuer leur propre évaluation des risques, pour chaque installation. Même si Gardasoft Vision Ltd a préparé minutieusement ces conseils, Gardasoft Vision Ltd décline toute responsabilité pour tout dommage, quel qu'il soit, à l'exception de ceux requis par la loi. La mise en péril volontaire ainsi que les actes de vandalisme ne sont pas couverts par le présent document et doivent être pris en compte par l'installateur.

## 5 Mounting the RTxxx

In order to provide fixing points to mount the unit onto a flat surface or bracket, insert M3 nuts into one or more of the slots in the base, see the illustration below. The quantity and position of these nuts depends on the user's requirements. One of the end covers features cut-outs to allow the M3 nuts to be easily slid into place without dismantling the controller. Ensure that the fixing screws used do not extend past the lower base surface by more than 5.5mm.

The PP704 kit is available for mounting the RTxxx on a DIN rail.

### 5.1 Environmental considerations

The RTxxx enclosure is a fire enclosure as long as it is mounted so that none of the connectors are facing downwards.

If a fire enclosure is used, the enclosure should be metal or plastic (with a flammability rating of UL94 V1 or better); with no holes below or to the sides of the RTxxx when mounted. Cable entries below the RTxxx should be through glands that also have a flammability rating of UL94 V1 or better. The RTxxx should be at least 10mm from any other part or side of the enclosure.

The RTxxx does not have an IP rating and must be mounted so that moisture and dirt cannot enter the unit.

The illustration below shows the dimensions of an RT2xx controller:

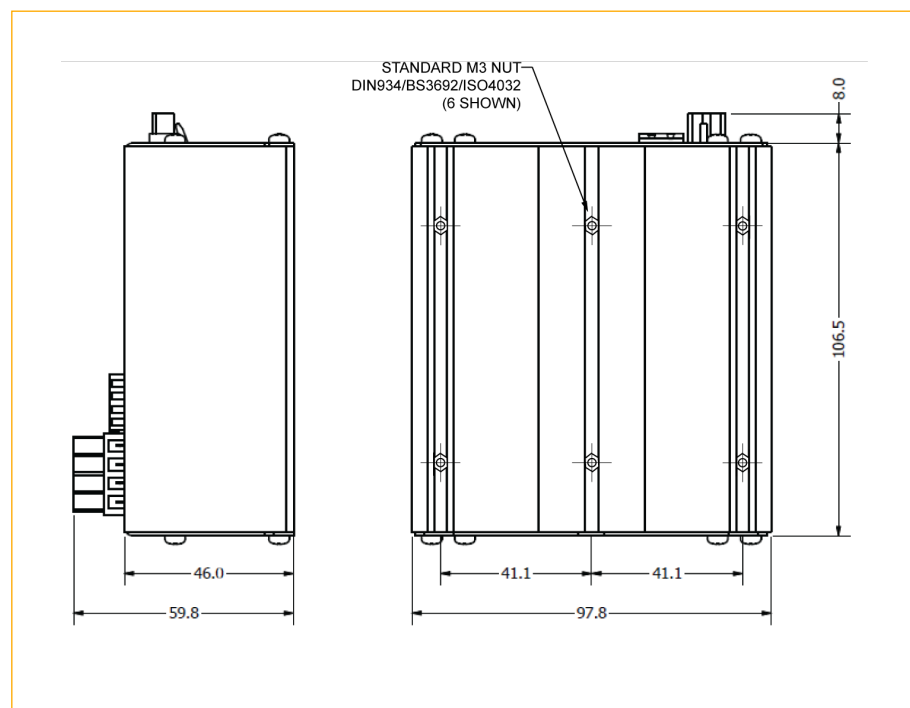



The illustration below shows the dimensions of an RT4xx controller:

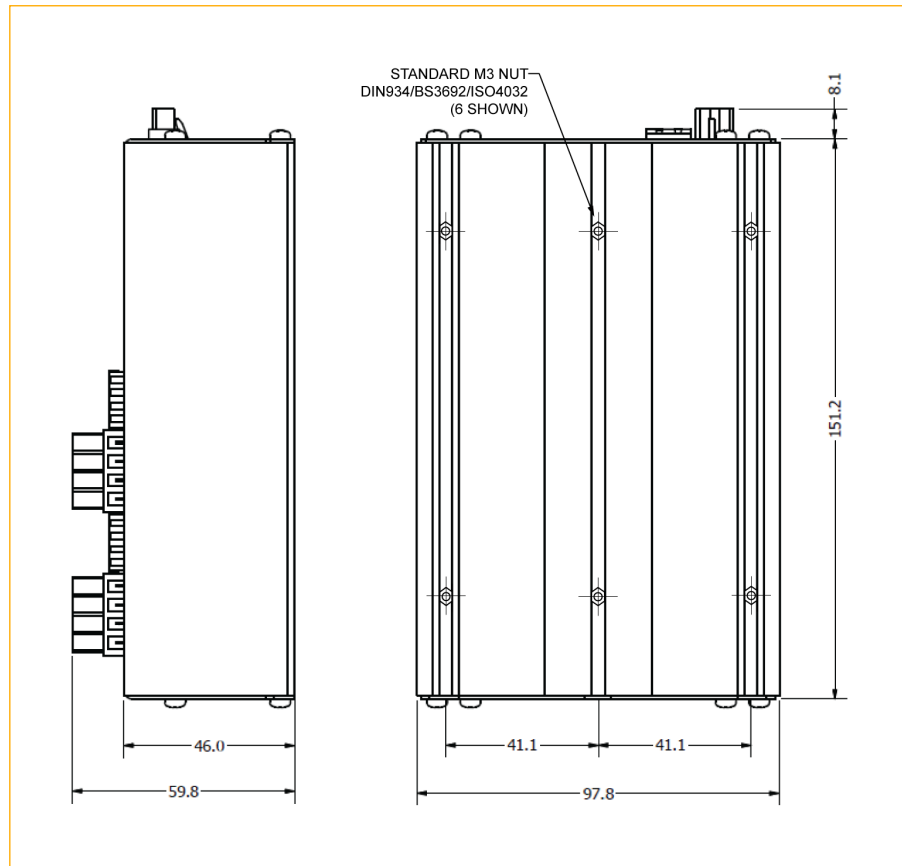

The illustration below shows the dimensions of an RT8xxF controller:

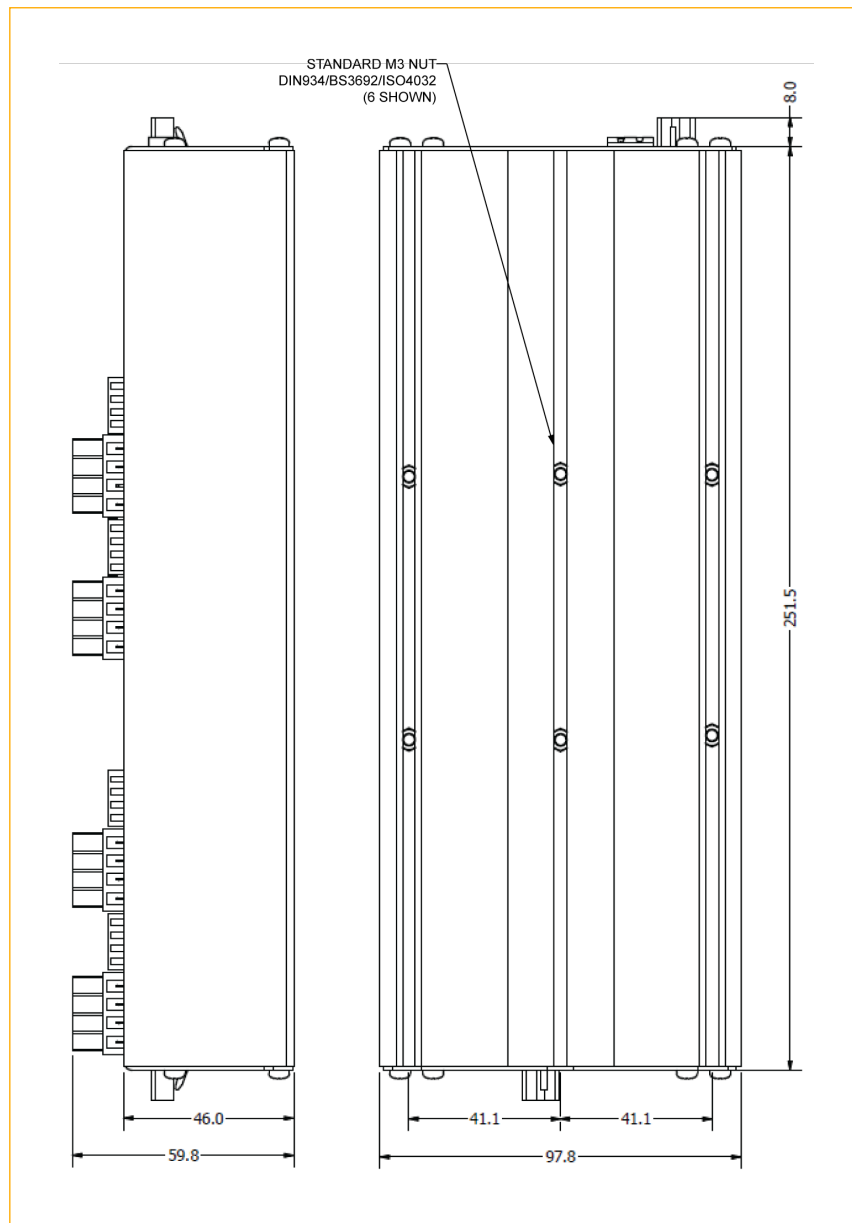

## 5.2 Electrostatic discharge

Electrostatic discharge (ESD) can damage equipment and impair the electrical circuitry inside your RTxxx. ESD damage occurs when electronic components are improperly handled and can result in complete or intermittent failures. On the RTxxx, this is relevant only to the trigger connections and power input.

## 6 Connections

See Section 13, Reference information for information about connection ratings

### 6.1 Power supply

In the unlikely event of a fault in the RTxxx, the maximum power dissipation in the unit can be:

*Power supply voltage x Max current delivered by power supply*



Either limit the power supply output current so that the RTxxx cannot dissipate more than 30W, or mount the unit in a fire enclosure.

Choose a PSU that is designed to limit its output current, or by setting the current limit on the supply (if this feature exists), or use a fuse. The fuse should be de-rated if mounted in an enclosure, as the temperature can be higher than the ambient temperature.

The external power supply must be capable of supplying at least the average output power for all active channels.

We recommend you use a regulated power supply with 100% short circuit protection. If however a non-regulated power supply is used, then the maximum ripple voltage of the power supply must not exceed 10% of the DC voltage.

Route the low voltage and mains wiring separately. If they must be loomed together, ensure that the insulation rating of the low voltage wiring is sufficient, or that you use supplementary insulation. The input connections are illustrated below:

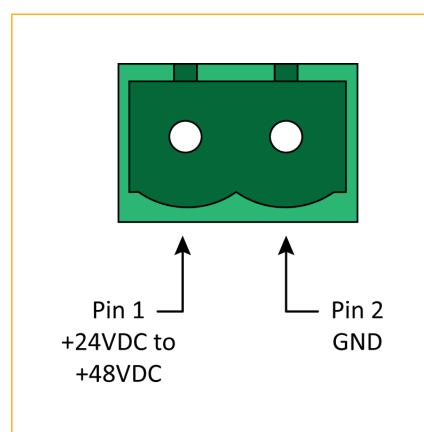

### 6.2 Lighting output

The lighting connections can exceed 46.7V but should not exceed 70V DC. Pulse peak voltages above 72V are considered hazardous. The

lighting connections must be shielded so they cannot be being touched both within the light and along the whole length of the cable. The lighting connections to an RTxxx are made through 4-way connectors as shown below:

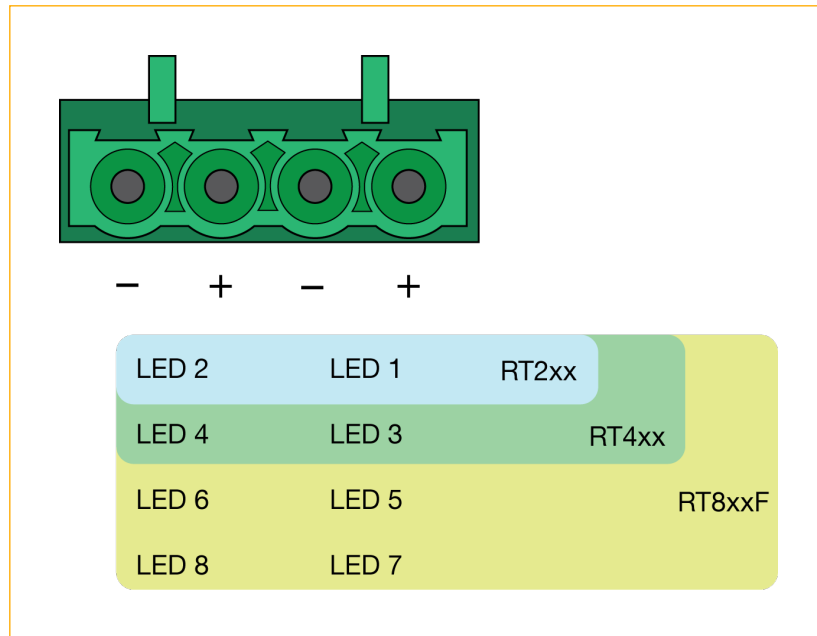

Ensure you set the current or voltage rating of your light before you connect it, see Section 8, Lighting setup.

The connectors fitted to an RT2xx, RT4xx, and an RT8xx series controller are shown in the illustrations below. You should refer to Section 6.3, Trigger inputs for the pin allocations of the trigger connectors.

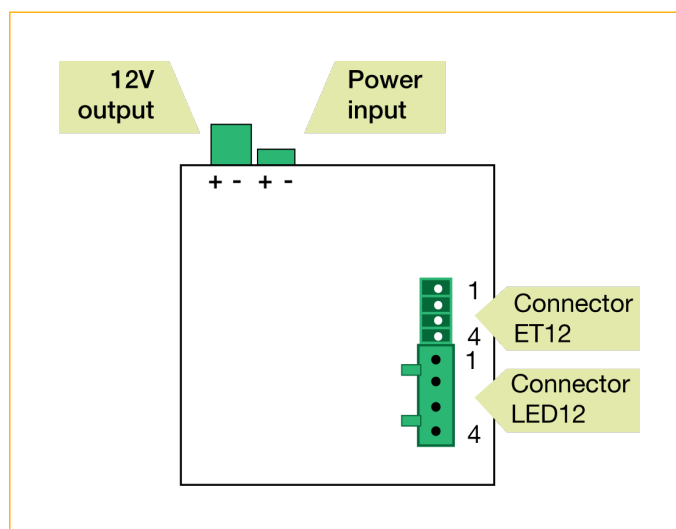

RT2xx

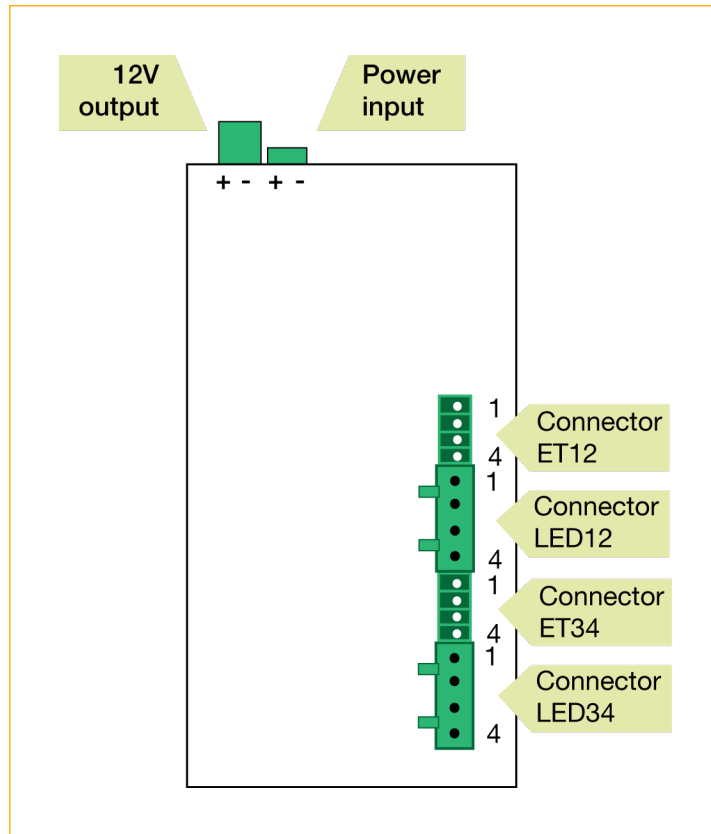

RT4xx

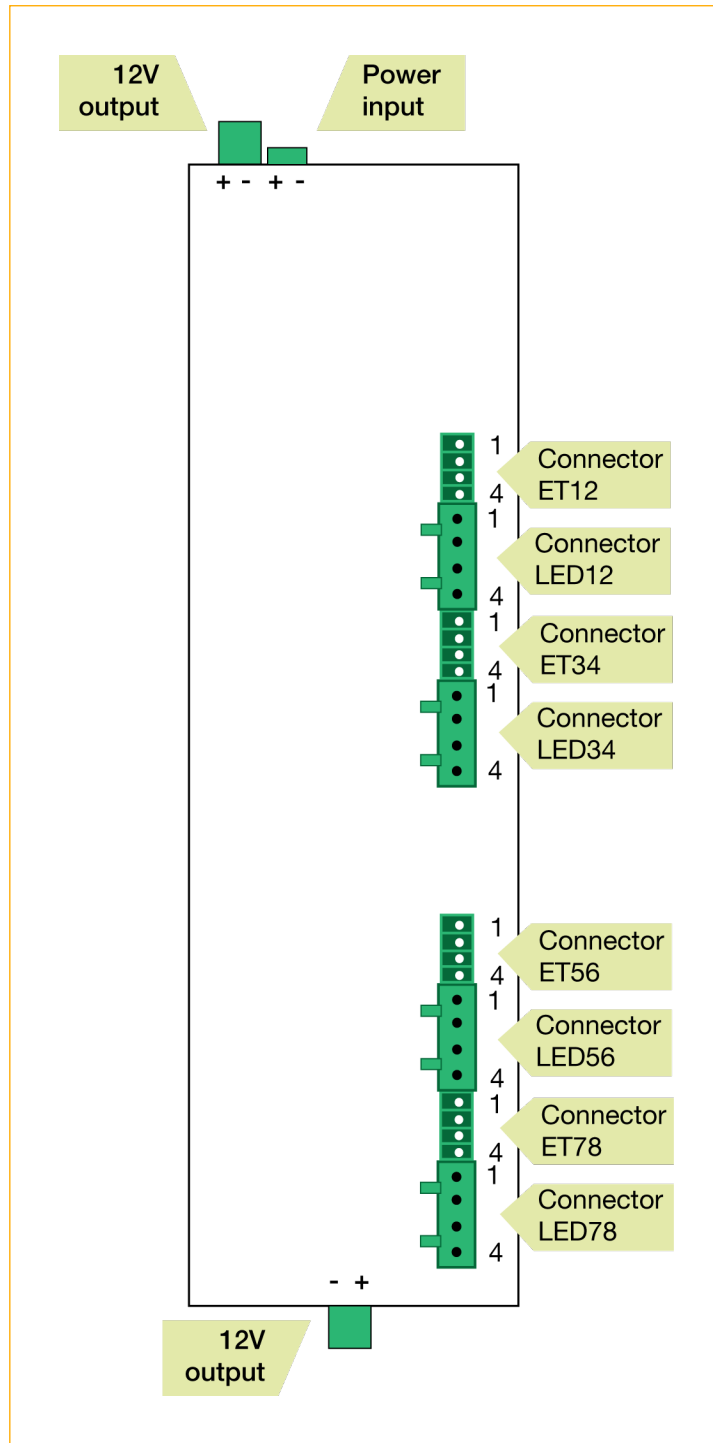

RT8xxF

### 6.3 Trigger inputs

The trigger inputs are opto-isolated 3V to 24V input, drawing a minimum of 3mA. The table overleaf describes the pin allocations for the RTxxx controllers' trigger connectors:

**Note:** All RTxxx controllers are fitted with Connector ET12. Connector ET34 is present on the RT4xx and RT8xxF series controllers. Connectors ET56 and ET78 are present only on RT8xxF controllers.

Pin	Connector ET12	Connector ET34	Connector ET56	Connector ET78
1	TRIG1 -	TRIG3 -	TRIG5 -	TRIG7 -
2	TRIG1 +	TRIG3 +	TRIG5 +	TRIG7 +
3	TRIG2 -	TRIG4 -	TRIG6 -	TRIG8 -
4	TRIG2 +	TRIG4 +	TRIG6 +	TRIG8 +

## 6.4 12V Power output

RT2xx and RT4xxx controllers have one 12V power supply output. The RT8xxF controller has two. These can supply up to 1A at 12V for powering cameras and other devices. Do not connect inductive loads or devices that take large peak currents. Do not exceed the current rating as these outputs are not fused.

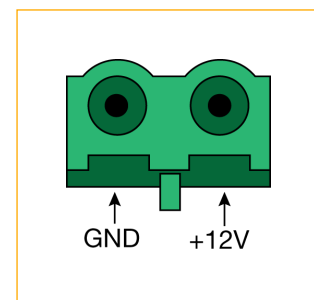

The pin allocation for the power supply output connector is shown above.

## 6.5 Ethernet connection

Ethernet connectivity is standard on RT220, RT420, and RT820F controllers. The RJ45 Ethernet connector requires a straight through cable to connect into a network switch, hub or router. It operates at 10Mbps per second (10Base-T).

## 6.6 Serial connection

The RS232 connector fitted to RT260, RT460, and RT860F controllers is a standard 9-way female D-type. A standard straight through cable can be used to connect the controller to a PC serial port. The communications port settings are 115Kbaud, no parity, 8 data bits and 1 stop bit.

The pin allocation for the serial connector is shown opposite:

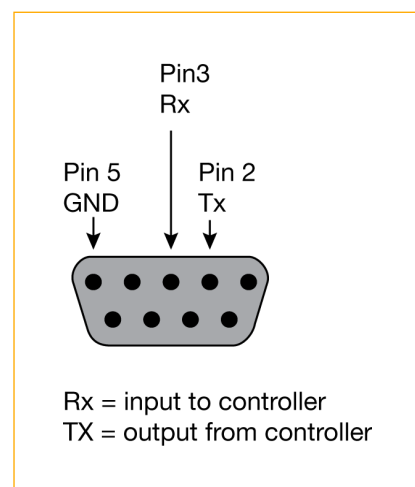

## 6.7 Connectors

The RTxxx packaging includes mating connectors for the power supply input, digital outputs, 12V power output, and lighting output.

Should spare parts be required these can be obtained from Würth ([www.we-online.com](http://www.we-online.com)), Farnell ([www.farnell.com](http://www.farnell.com)), or Newark ([www.newark.com](http://www.newark.com)). See the table below for further information.

Connector	Description	Würth part number	Supplier part number
Power input	2W screw terminal free socket, 5.08mm	691 351 500 002	Farnell: 1641952 Newark: 19P1467
Trigger input	4W screw terminal free socket, 3.5mm	691 361 100 004	Farnell: 1841351 Newark: 16T1571
Lighting output	4W screw terminal free plug, 5.08mm	691 348 500 004	N/A
12V output	2W screw terminal free plug, 5.08mm	691 348 500 002	N/A



## 7 General description

The RTxxx series of current controllers provide repeatable intensity control of LED lighting for machine vision applications. This includes the intensity control, timing and triggering functions required for machine vision systems.

LED lighting needs a constant current supply as small variations in voltage can cause large variations in light output. The RTxxx series of controllers can set currents in steps of 0.1% (with a lower limit of 2.5mA steps) to give very fine control of intensity.

Several modes of operation are separately available for each channel:

### » Continuous

In continuous mode the output is a continuous brightness.

### » Pulse (Strobe)

In pulse mode output is pulsed once per trigger. One trigger input is used as a trigger. The delay from trigger to pulse, the pulse duration and the brightness can be set.

### » Switched

In switched mode a trigger input is used to switch the output current on and off. The output is only enabled when the trigger input has a voltage on it.

### » Selected

In selected mode a trigger input is used to select between two different intensities.

With the exception of the RT200, controllers in the RTxx series are set up using an Ethernet port or serial port. The set up is non-volatile, so the RTxxx resumes the same operation after a power cycle.

### 7.1 Output modes

The trigger inputs are used as described overleaf:

**Note:** The P flag inverts the sense of the trigger input, see Section 6.3, Trigger inputs.

#### 7.1.1 Continuous output, switched output, selected output

Mode	Trigger input	Output
Continuous	Unused	Output is on

Mode	Trigger input	Output
Switched	Trigger = off Trigger = on	Output is off Output is on
Selected	Trigger = off Trigger = on	Output is continuous brightness 2 Output is continuous brightness 1
Pulsed	Trigger rising edge Trigger falling edge	Pulse is triggered if P flag = 1 Pulse is triggered if P flag = 0

In continuous mode the output current is fixed and continuous. Switched mode uses a trigger input to switch the output on or off.

Selected mode uses a trigger input to select between the two different brightness settings. Brightness 1 must be greater than brightness 2. The P flag can be used to invert the trigger input.

The output current can be varied from 0% to 100% of full brightness.

## 7.2 Pulsed output

The output is off by default. When the RTxx is triggered, it waits for a delay and then pulses the output. The delay, pulse width, retrigger delay and pulse intensity are all configurable.

Retrigger delay is the minimum allowed time from one trigger to the next. Any triggers that happen too soon after the previous trigger are ignored. The retrigger delay is set in multiples of 100 $\mu$ s.

When connected to a light, the brightness can be set up to 1000% of its rating, but only for short periods and at low duty cycles, so that the lighting does not overheat and get damaged. The table below shows the operating limits:

Output brightness	Maximum pulse width	Maximum duty cycle
0 to 100%	999ms	100%
101% to 200%	30ms	30%
201% to 300%	10ms	20%
301% to 500%	2ms	10%
501% to 1000%	1ms	5%

The duty cycle is limited by ignoring triggers which are too soon after the previous trigger.

For example, if the brightness is set to 250%, then the RTxxx does not allow pulses greater than 10ms long. With 10ms pulses, if a trigger occurs within 50ms of a previous trigger (so that the duty cycle would be greater than 20%) the trigger is ignored.

### 7.3 Fault detection

The RTxxx controller detects the following errors. The error code is shown on the webpage of an Ethernet controller (see Section 11, Webpage configuration (RT220, RT420, RT820F)), or the communications window of an RS232 controller (see Section 12, Command configuration). When the output current is less than 100mA, some fault detection is disabled.

You can issue a **GR** command to cancel the error (see Section 12, Command configuration). The RTxxx controller re-senses the light.

Error	Reason
34, 37	Internal power dissipation is too high. Output turned off.
35, 43	Output current to lighting is too low. The light is open circuit or there is not enough supply voltage for the requested output current.
36	If the output voltage is too low, the controller detects that the output is short circuited.
37	The voltage required for the lighting has increased too much. Check for ageing of the lighting or a failed LED.
38	The voltage required for the lighting has decreased too much. Check for ageing of the lighting or a failed LED.

### 7.4 Light auto-sensing

When a channel does not have a light connected, the RTxxx continually tries to supply a very small current.

When a light is connected, it flashes for a short time (the light is not damaged by this) until the RTxxx detects that it is connected.

For voltage rated lights, the light is briefly driven at an increasing amount until 100% output brightness is achieved in order to sense the current rating of the light. This can generate the following errors:

Display error	Comms error number	Reason
E1	Err 21	Current output is too low. This may be because the light has become disconnected.
E2	Err 22	The lighting required more than the maximum available current for the voltage rating.
E3	Err 23	Current output is not what was expected. The controller might need calibrating.
E6	Err 23	The power rating of the light exceeds the maximum power rating.

## 7.5 Light characterisation

You can reduce the time it takes for your RTxxx to reach high accuracy in time-critical machine vision systems when changing from one overdrive brightness setting to another. This can be done by instructing the controller to make current and voltage measurements up to a customer specified brightness limit when the light is characterised. This is called the characterisation limit. The measured overdrive voltage and current relationship is stored in the RTxxx and allows it to respond much more rapidly to new overdrive parameters up to that limit.

When a light is detected, the characteristics of the light are measured up to the brightness set for the characterisation limit. It is not essential to set this value and it can be left at 200 (meaning 200% brightness). The feature can also be turned off by setting this value to 0.

You can change the characterisation limit brightness through the RTxxx's webpages (see Section 11, Webpage configuration (RT220, RT420, RT820F)) or by command (see Section 12, Command configuration).

## 7.6 Current adjust

The current adjust feature provides a more accurate and repeatable output current. After setting an output current, the controller continually measures the actual current and adjusts the output to

maintain the target current. This will compensate for any inaccuracies such as temperature drift in the controller.

If the output current is less than 100mA, the adjustments the feature imposes can have a significant effect on the lighting brightness. If some flickering is seen, it is recommended that the current adjust feature is turned off.

Current adjust can be turned on and off from the web page interface (see [Section 11, Webpage configuration \(RT220, RT420, RT820F\)](#)) or by using the RE command (See [Section 12, Command configuration](#)).

## 7.7 Cold start

You can clear the RTxxx configuration to its default settings - this clears the lighting ratings and sets all channels to 50% brightness continuous operation. You can do this by sending the **CL** command using Ethernet or serial connection.

## 8 Lighting setup

The rating of the light must be set by the user. This rating is the supply to the lighting that should be used to get 100% continuous brightness from the light. The RTxxx is compatible with both current and voltage rated lighting.

You must enter the rating for the light before connecting it to the controller, or if you replace it with a different type of light. If a light is replaced with the same type of light then the previous rating still applies.

Consult the specification or labelling for the light. For commercially available lighting modules, if a voltage and current rating is given, use the current rating. If a voltage and wattage rating is given, use the voltage rating. Otherwise use the current rating. For 'homemade' lights using single LEDs or arrays of LEDs use the current rating from the LED datasheet.

You can set the current rating from 0.01A to 3A in steps of 0.01A, and you can set the voltage rating from 12V to 36V in steps of 1V.

When you connect a voltage rated light, the RTxxx automatically senses the current rating of the light.

Voltage and current rated lights are both driven with a constant current. This gives better brightness stability and allows the RTxxx to prevent the light being driven with too much power.

To set the rating of a light on RS232 or Ethernet versions of the RTxxx controller, use the **VL** command (see [Section 12, Command configuration](#)), or use the internal webpages on Ethernet versions of the RTxxx controller (see [Section 11, Webpage configuration \(RT220, RT420, RT820F\)](#)).

## 9 Front panel configuration (RT200)

Using the front panel keypad, you can set the configuration for each channel, set a keylock code so unauthorised users cannot change any settings, set the internal trigger time, view trigger status, and set the voltage or current rating.

### 9.1 Startup

On power up, the RT200 displays **b** for five seconds followed by **8.8.8.** to show that the display is working, then **RT2** and **00**, followed by the firmware version (for example **039**). The controller is then ready for operation.

When the RT200 is not being configured the display indicates the status of both channels as shown below:

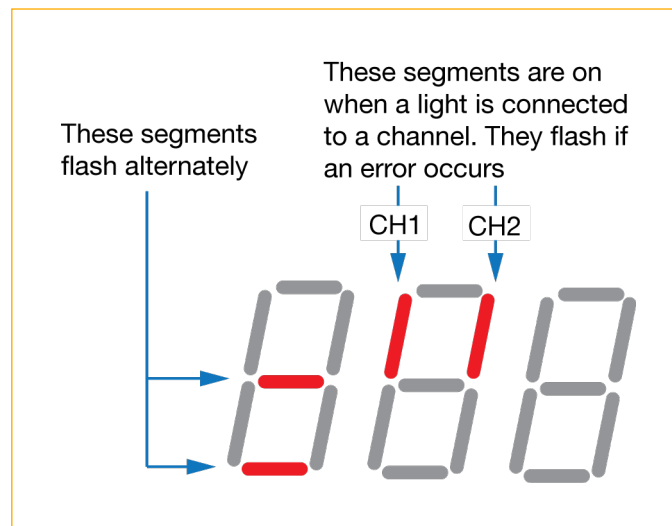

The RT200 displays an error if a light is connected but no rating has been specified. See Section 9.2, Setting the light rating.

To configure the RT200 from the front panel, press and hold **SEL** for 1 second. **CH1** is displayed. You can then use the **▲** and **▼** keys to scroll through the menu, pressing the **SEL** button to access the required set up as shown in the table below:

Display	Select to:
<b>CH1</b>	Set up output channel 1
<b>CH2</b>	Set up output channel 2
<b>LOC</b>	Set up a key lock

Display	Select to:
<b>FrE</b>	Set up the internal trigger
<b>trg</b>	View the trigger status
<b>UAL</b>	View the output current
<b>rAt</b>	Set the lighting rating

During the setup of a channel, the trigger can be set to active high or low according to the **P** flag setting. Error checking can be enabled or disabled using the **E** flag.

## 9.2 Setting the light rating

Press and hold **SEL** for one second, **CH1** is displayed. Use the ▲ and ▼ buttons to scroll to **rAt** and follow the keystrokes below:



**rAt** is displayed. Press the **SEL** button.

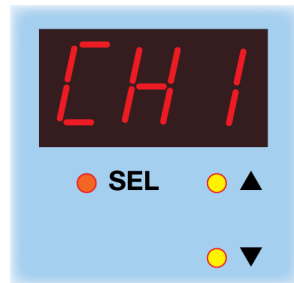

Use the ▲ and ▼ buttons to select the channel you want to set the rating for, and press the **SEL** button.



**Cur** is displayed. Press the **SEL** button if your light is current rated. **Or...**



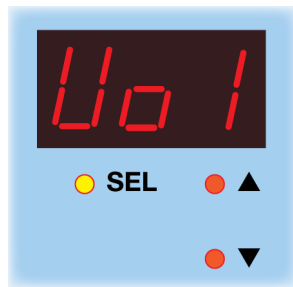

If your light is voltage rated, use the ▲ and ▼ buttons to select **Uo1** and press the **SEL** button.



For current rated lights, use the ▲ and ▼ buttons to set the rating in Amps, and press the **SEL** button. **Or...**

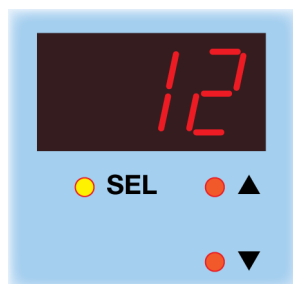

For voltage rated lights use the ▲ and ▼ buttons to set the rating in volts, and press the **SEL** button.

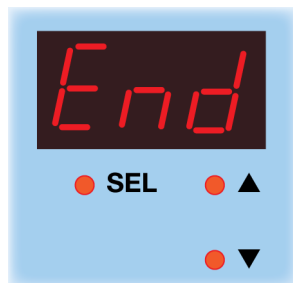

The light's rating is set up and the RT200 is ready to use.

### 9.3 Setting up continuous output

Press and hold **SEL** for one second, **CH1** is displayed. Use the ▲ and ▼ buttons to select the channel you want to set up, and follow the keystrokes below:



The channel you want to set up is displayed. Press the **SEL** button.

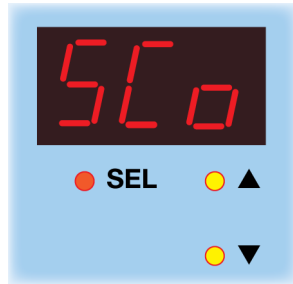

Use the ▲ and ▼ buttons to select **SCo** and press the **SEL** button.



**bri** is displayed. Press the **SEL** button to select the light's intensity.



Use the ▲ and ▼ buttons to set the intensity from 1% to 99.9%. The default setting is 50%. Press the **SEL** button.

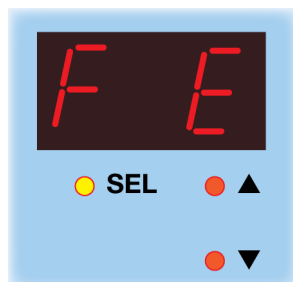

To set the error detection, press the **SEL** button with **F E** displayed. **Or...**

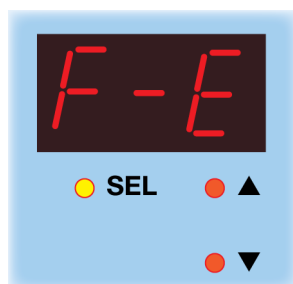

If you wish to disable the error detection, use the ▲ and ▼ buttons to select **F-E**, and press the **SEL** button.

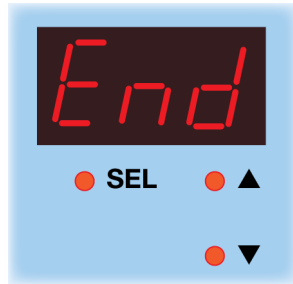

Continuous output is set up on the RT200.

## 9.4 Setting up switched output

Switched output is when the light remains on for as long as there is a signal on the trigger input. Press and hold **SEL** for one second, **CH1** is displayed. Use the **▲** and **▼** buttons to select the channel you want to set up, and follow the keystrokes below:



The channel you want to set up is displayed. Press the **SEL** button.

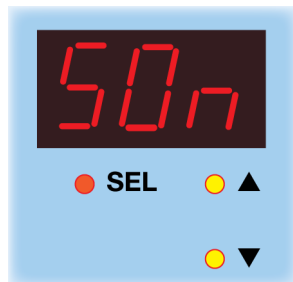

Use the **▲** and **▼** buttons to select **SO**n and press the **SEL** button.



**bri** is displayed. Press the **SEL** button to select the light's intensity.



Use the **▲** and **▼** buttons to set the intensity from 1% to 99.9%. The default setting is 50%. Press the **SEL** button.

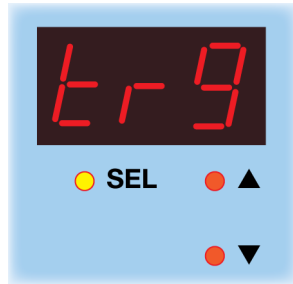

**trg** is displayed. Press the **SEL** button.



Use the ▲ and ▼ buttons to select the trigger (**IP1** or **IP2**) you want to set up, and press the **SEL** button.

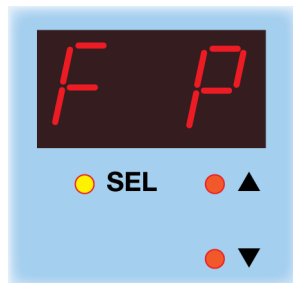

To set the trigger polarity so that it is active high, press the **SEL** button with **F P** displayed. **Or...**

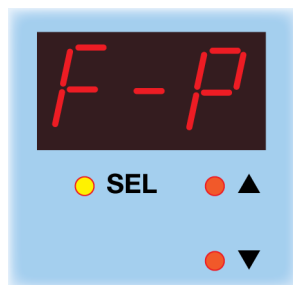

If you wish to set the trigger polarity so that it is active low, use the ▲ and ▼ buttons to select **F-P** and press the **SEL** button.

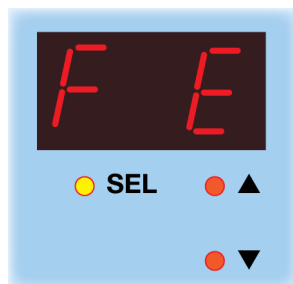

To set the error detection, press the **SEL** button with **F E** displayed. **Or...**

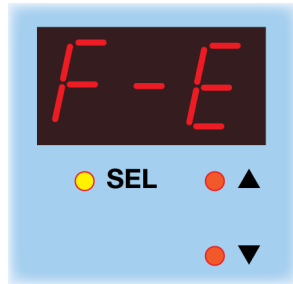

If you wish to disable the error detection, use the ▲ and ▼ buttons to select **F-E**, and press the **SEL** button.

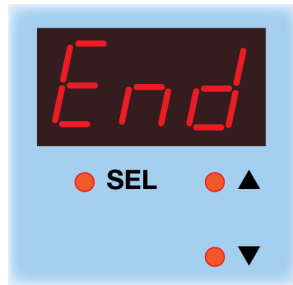

Switched output is set up on the RT200.

## 9.5 Setting up selected output

Set up selected output if you want to switch between to lighting levels on a trigger input. Press and hold **SEL** for one second, **CH1** is displayed. Use the ▲ and ▼ buttons to select the channel you want to set up, and follow the keystrokes below:



The channel you want to set up is displayed. Press the **SEL** button.



Use the ▲ and ▼ buttons to select **SSE** and press the **SEL** button.

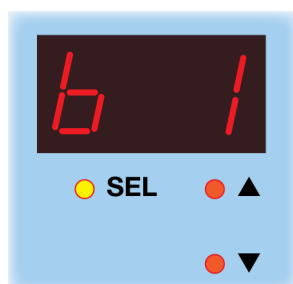

**b1** is displayed. Press the **SEL** button to set the first intensity level.

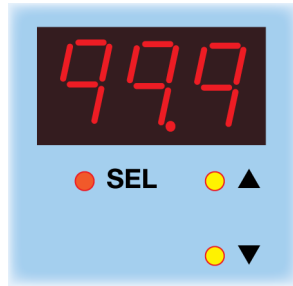

Use the ▲ and ▼ buttons to set the first intensity level from 1% to 99.9%. The default setting is 50%.

Press the **SEL** button.

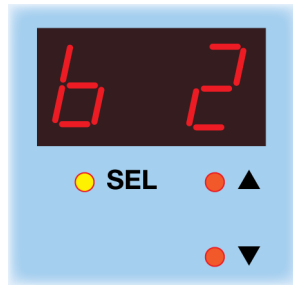

**b2** is displayed. Press the **SEL** button to set the second intensity level.

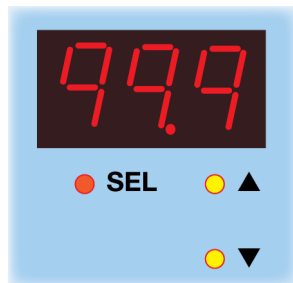

Use the ▲ and ▼ buttons to set the second intensity level from 1% to 99.9%. The default setting is 50%.

Press the **SEL** button.

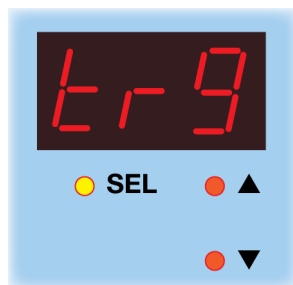

**trg** is displayed. Press the **SEL** button.



Use the ▲ and ▼ buttons to select the trigger (**IP1** or **IP2**) you want to set up, and press the **SEL** button.

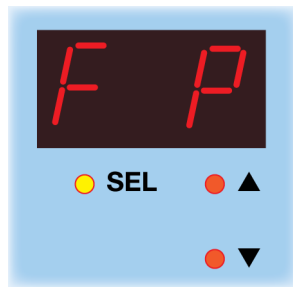

To set the trigger polarity so that it is active high, press the **SEL** button with **F P** displayed. **Or...**

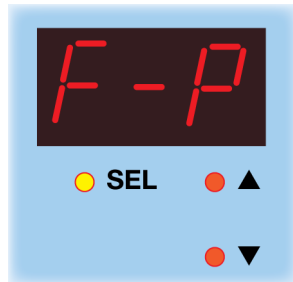

If you wish to set the trigger polarity so that it is active low, use the **▲** and **▼** buttons to select **F-P** and press the **SEL** button.

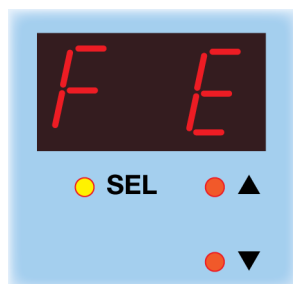

To set the error detection, press the **SEL** button with **F E** displayed. **Or...**

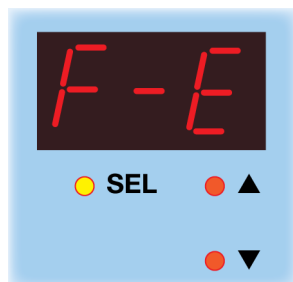

If you wish to disable the error detection, use the **▲** and **▼** buttons to select **F-E**, and press the **SEL** button.

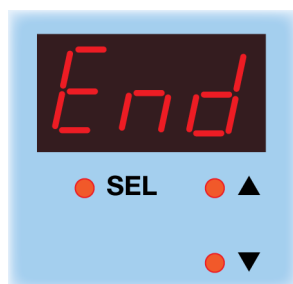

Selected output is set up on the RT200.

## 9.6 Setting up pulsed operation

Pulsed operation allows you to set up the characteristics of the lighting pulse irrespective of the trigger pulse duration. Press and hold **SEL** for one second, **CH1** is displayed. Use the **▲** and **▼** buttons to select the channel you want to set up, and follow the keystrokes below:



The channel you want to set up is displayed. Press the **SEL** button.

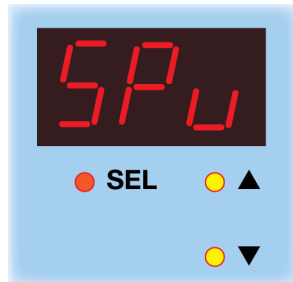

Use the ▲ and ▼ buttons to select **SPu** and press the **SEL** button.



**bri** is displayed. Press the **SEL** button to set the lighting intensity.

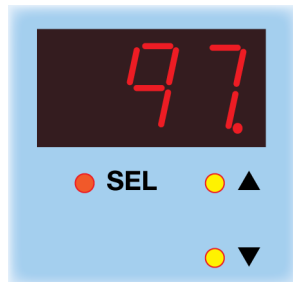

Use the ▲ and ▼ buttons to set the lighting intensity from 1% to 999%. Press the **SEL** button.



**dEL** is displayed. Press the **SEL** button to set up the delay time as described in Section 9.7, Setting time periods.

Press the **SEL** button.



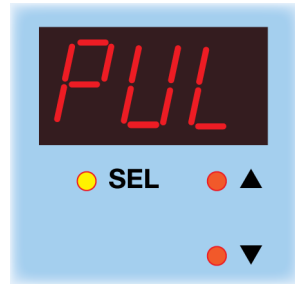

**PUL** is displayed. Press the **SEL** button to set up the pulse width as described in Section 9.7, Setting time periods.

Press the **SEL** button.

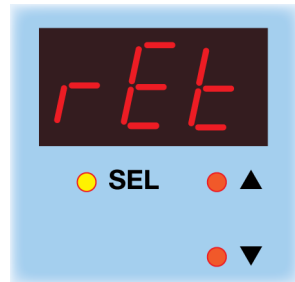

**rEt** is displayed. Press the **SEL** button to set up the retrigger time as described in Section 9.7, Setting time periods.

Press the **SEL** button.



**trg** is displayed. Press the **SEL** button.



Use the ▲ and ▼ buttons to select the trigger (**IP1** or **IP2**) you want to set up, and press the **SEL** button.

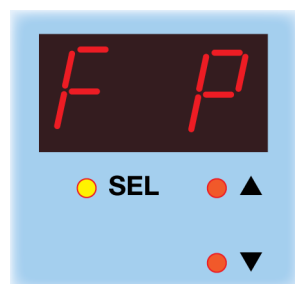

To set the trigger polarity so that it is active high, press the **SEL** button with **FP** displayed. **Or...**



If you wish to set the trigger polarity so that it is active low, use the ▲ and ▼ buttons to select **F-P** and press the **SEL** button.

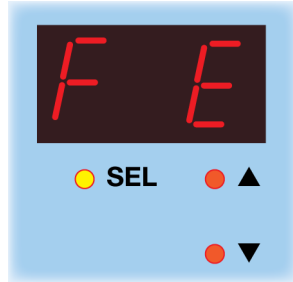

To set the error detection, press the **SEL** button with **F E** displayed. **Or...**

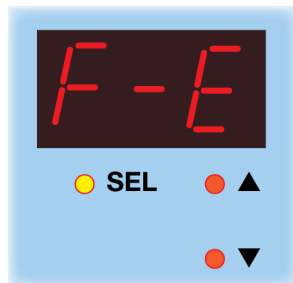

If you wish to disable the error detection, use the ▲ and ▼ buttons to select **F-E**, and press the **SEL** button.

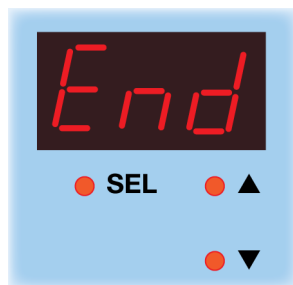

Pulsed operation is set up on the RT200.

## 9.7 Setting time periods

When the RT200 requires you to enter a numeric value, the right hand digit flashes to indicate you can use the ▲ and ▼ buttons to change the value.

To set pulse delay, retrigger, and pulse width values a scheme is used where the exponent (power of 10) of the value is set. The exponent values are as follows:

Exponent value	Multiplier	Number format	Range of values
E-2	0.01	9.99	Values are displayed in seconds from 10ms to 5s in steps of 10ms.
E-3	0.001	999.	Values are displayed in milliseconds from 1ms to 999ms in steps of 1ms.
E-4	0.0001	99.9	Values are displayed in milliseconds from 0.1ms to 99.9ms in steps of 0.1ms.
E-5	0.00001	9.99	Values are displayed in milliseconds from 0.01ms to 9.99ms in steps of 0.01ms.
E-6	0.000001	999.	Values are displayed in microseconds from 1µs to 999µs in steps of 1µs.

**Note:** The permitted range of values for pulse delay, pulse width, and retrigger time is given in Section 13, Reference information, or as limited by the operating conditions of the light.

Follow the keystrokes below to enter numerical data into the RT200 using the above scheme:



**E-2** is displayed. Press the **SEL** button to enter time values from 10ms to 5s.

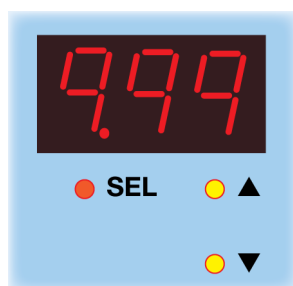

Use the ▲ and ▼ buttons to select the required value in steps of 10ms. Press the **SEL** button.

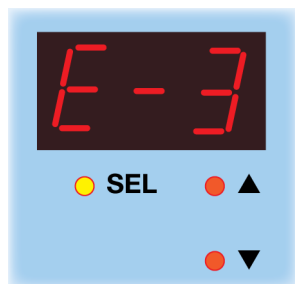

**E-3** is displayed. Press the **SEL** button to enter time values from 1ms to 999ms.

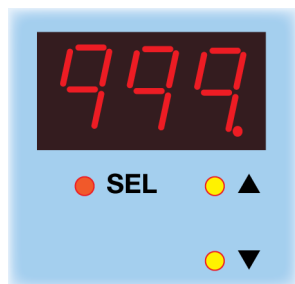

Use the **▲** and **▼** buttons to select the required value in steps of 1ms. Press the **SEL** button.

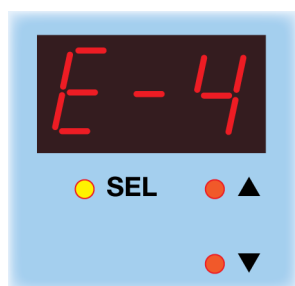

**E-4** is displayed. Press the **SEL** button to enter time values from 0.1ms to 99.9ms.



Use the **▲** and **▼** buttons to select the required value in steps of 0.1ms. Press the **SEL** button.

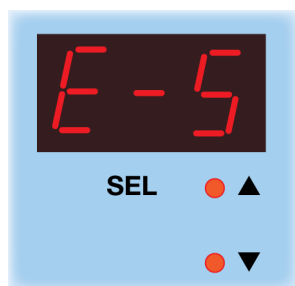

**E-5** is displayed. Press the **SEL** button to enter time values from 0.01ms to 9.99ms.

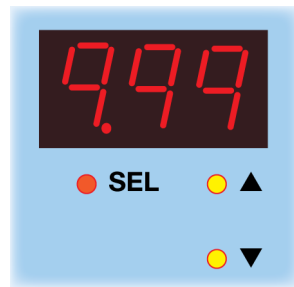

Use the ▲ and ▼ buttons to select the required value in steps of 0.01ms. Press the **SEL** button.



**E-6** is displayed. Press the **SEL** button to enter time values from 1µs to 999µs.

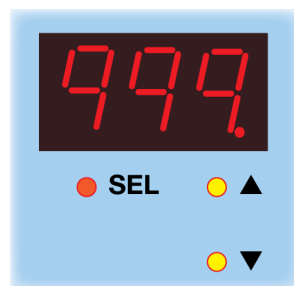

Use the ▲ and ▼ buttons to select the required value in steps of 1µs. Press the **SEL** button.

## 9.8 Setting the internal trigger timer

You can set an internal trigger timer when the RT200 is in pulse mode. When set, the RT200 triggers with the same delay and pulse width already set up, as described in [Section 9.6, Setting up pulsed operation](#). External triggering remains unchanged.

Ensure the RT200 is set to pulsed operation. To set the period of the internal trigger, press and hold **SEL** for one second and follow the keystrokes below:



Use the ▲ and ▼ buttons to select **FrE** and press the **SEL** button.

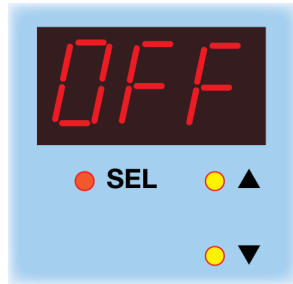

**OFF** is displayed. Press the **SEL** button to end the sequence. **Or...**

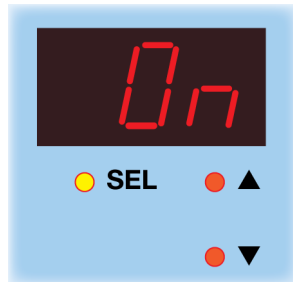

Use the ▲ and ▼ buttons to select **On** and press the **SEL** button.

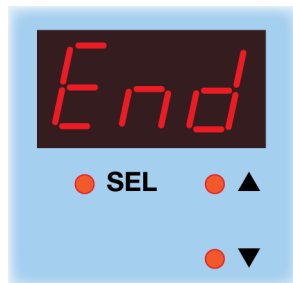

The internal trigger is running with the parameters set up in Section 9.6, Setting up pulsed operation.

## 9.9 Using the key lock

You can lock the RT200 front panel keypad so that unauthorised users cannot change the configuration. To do this you can set a numeric code from 0 to 255, which provides moderate protection.

To lock the keypad, press and hold **SEL** for one second. **CH1** is displayed. Follow the keystrokes below:

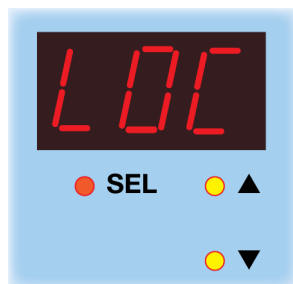

Use the ▲ and ▼ buttons to select **LOC**, and press the **SEL** button.

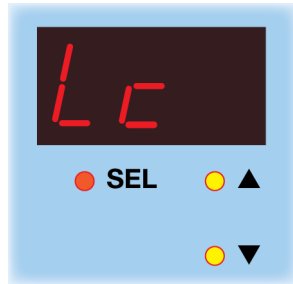

To set up the lock code, use the ▲ and ▼ buttons to select **Lc**. Press the **SEL** button.

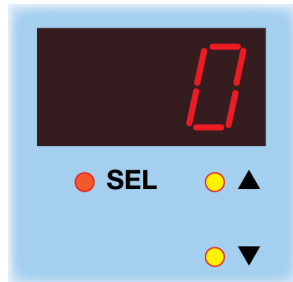

**0** is displayed. Use the ▲ and ▼ buttons to set a lock code value from 0 to 255, and press the **SEL** button.

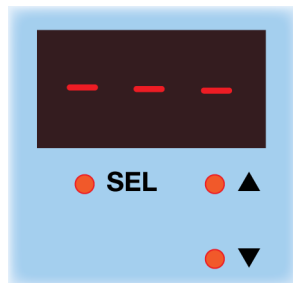

The RT200 keypad is locked.

To unlock the keypad, press and hold **SEL** for one second and follow the keystrokes below:

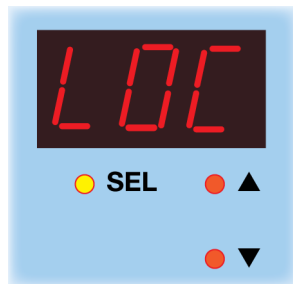

**LOC** is displayed. Keep pressing the **SEL** button.



**Un** is displayed. Press the **SEL** button.

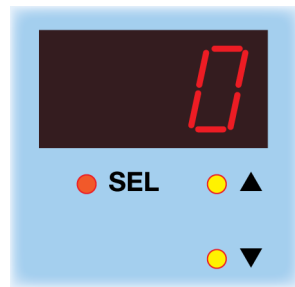

Use the ▲ and ▼ buttons to enter the lock code and press the **SEL** button.



**CH1** is displayed and the RT200 keypad is unlocked.

If the code entered is incorrect, **LOC** is displayed.

## 9.10 Viewing the trigger status

You can view the trigger input status and whether the light is pulsing when the RT200 is set to pulse mode. To do this, press the **SEL** button for one second and **CH1** is displayed. Use the ▲ and ▼ buttons to select **trg** and press **SEL**. The display shown below appears:

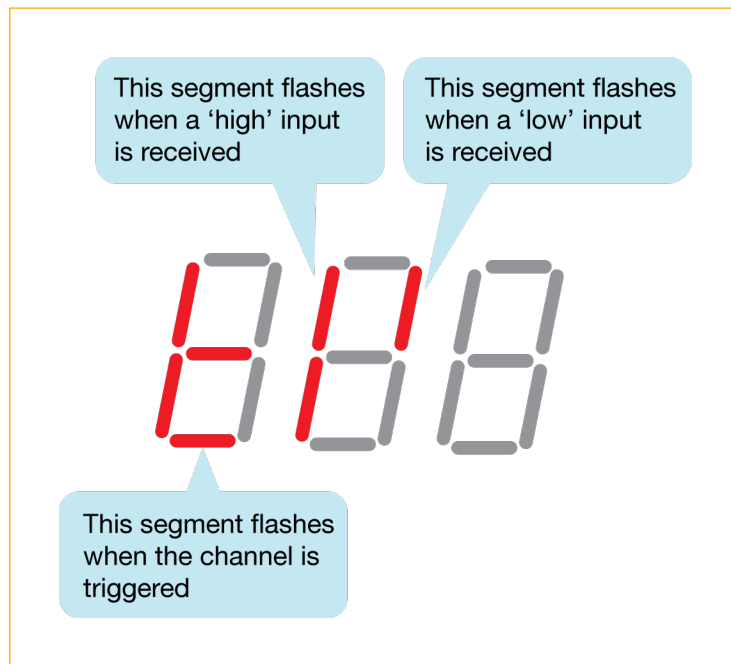

## 9.11 Viewing the output current

You can view an approximate measure of the output current from the RT200 front panel. The current measurement is updated roughly once per second, but this can be slower when the RT200 is set to pulsed operation.



To view the output current, press the **SEL** button for one second and **CH1** is displayed. Follow the keystrokes below:

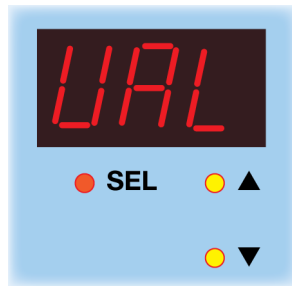

Use the ▲ and ▼ buttons to select **UAL** and press the **SEL** button.



**CH1** is displayed. Use the ▲ and ▼ buttons to select **CH2** if you wish to view the output current from channel 2. Press the **SEL** button.

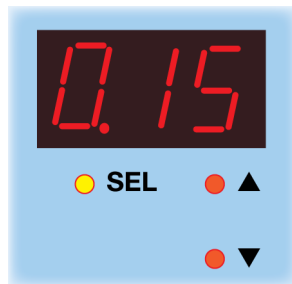

The measured output current is displayed. Press the **SEL** button.

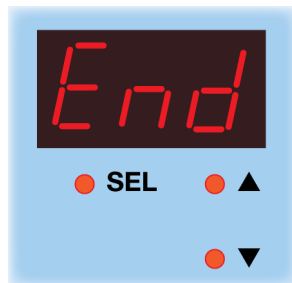

Continue to use the RT200 normally.

## 10 Ethernet communication (RT220, RT420, RT820F)

You may need to ask your network administrator for advice about setting up the Ethernet connection.

Ethernet set up is not affected by cold booting the RTxxx.

See Application note APP923 (available from [www.gardasoft.com](http://www.gardasoft.com)) for troubleshooting Ethernet problems.

### 10.1 Connection

The Ethernet link uses a 10Base-T connection on an RJ45 connector. The RTxxx is usually connected to a network switch, hub or router, but you can connect it directly into the network port on a PC using a crossover cable.

### 10.2 IP Address

The RTxxx needs an IP address to communicate over Ethernet. There are two ways to get an IP address; either programmed into the unit or using DHCP.

For DHCP mode, the RTxxx acquires its IP address, subnet mask and gateway address from a DHCP server. Otherwise the RTxxx has a fixed IP address, subnet mask and gateway address.

DHCP mode or the IP address can be set and read using the GardasoftMaint program available at [www.gardasoft.com](http://www.gardasoft.com).

The GardasoftMaint window is shown overleaf:

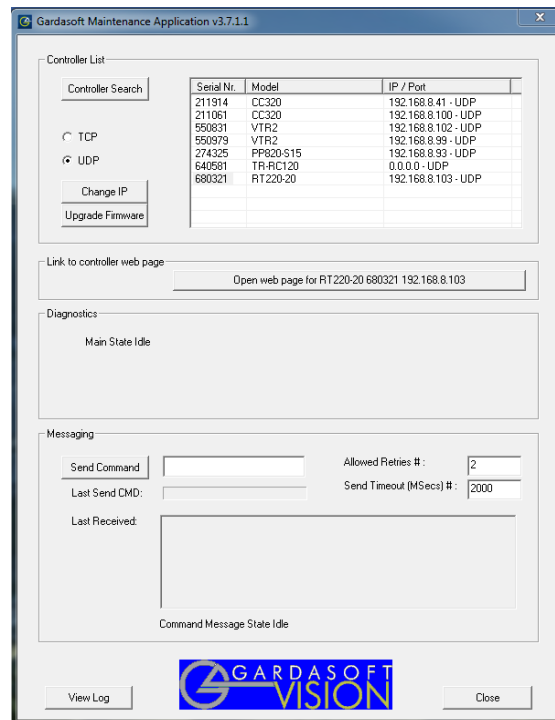

GardasoftMaint allows you to view the controllers on your network, change their IP addresses and upgrade their firmware if it becomes necessary. In the messaging section of GardasoftMaint, you can communicate with your controller using the commands explained in [Section 12, Command configuration](#). You can also open the selected controller's web pages at the click of a button. For more information about the RTxxx's web pages, see [Section 11, Webpage configuration \(RT220, RT420, RT820F\)](#).

### 10.2.1 DHCP

Most networks use a DHCP server. If there is a PC on the network, you may be able to find out whether a PC on the same network uses DHCP as follows:

- i. Right-click on the Windows 10™ icon at the left of your PC's task bar.
- ii. Select **Network Connections**.
- iii. In the *Status* pane, click **View your network properties**.

*DHCP enabled* will be set to 'yes' if DHCP is in use.

You can find out what IP address is being used by a PC at any time by following the steps below:

- i. Right-click on the Windows 10™ icon at the left of your PC's task bar.
- ii. Select **Network Connections**.

- iii. In the left-hand pane, click on **Ethernet**.
- iv. Click on your network icon under *Ethernet*.  
Your IP address will be given as the 'IPv4 address'.

### 10.2.2 Fixed IP address

When using a fixed IP address, you must ensure that you use an IP address that is not being used by any other device on the network. It is usual to keep the first three numbers of the IP address the same as other devices and to change only the last number. For example, if you have a network consisting of a PC (IP address 192.168.1.35) and two RTxxs could be allocated addresses 192.168.1.201 and 192.168.1.202.

## 10.3 Automatic sensing

All the features below are implemented in sample C++ source code available for download from [www.gardasoft.com](http://www.gardasoft.com).

The RTxxx sends a message on three events:

- i. On power up
- ii. When an IP address is received or renewed by DHCP
- iii. When an enquiry message is received.

On the first two events, the message is broadcast. On the third it is a reply to a single IP address.

An enquiry message is a UDP packet from source port 30310, destination port 30311 with the message body 'Gardasoft Search' (8-bit ASCII, 13 characters).

The message output by the RTxxx is a UDP packet from source port 30311, destination port 30310. It is formatted as:

```
Gardasoft,RT220-20,000000,111111111111,22222222
```

(8-bit ASCII, 44 characters) where,

000000	The serial number of the unit
111111111111	The MAC address in 6 HEX bytes
22222222	The IP address in 4 HEX bytes

For example; for RT220-20, serial number 12345, IP address 192.168.1.103, MAC address 00.0B.75.01.80.99 the packet is formatted:

```
Gardasoft,RT220-20,012345,000B75018099,C0A8016
```

## 11 Webpage configuration (RT220, RT420, RT820F)

You can set up the RTxx through its own internal web pages. Click the **Open webpage...** button in GardasoftMaint to take you directly to the RTxxx's webpages. You can also type the controller's IP address (displayed in GardasoftMaint) into your web browser, which will display the Main screen. GardasoftMaint software is available from [www.gardasoft.com/Downloads](http://www.gardasoft.com/Downloads).

### 11.1 Main page

The main page (shown below) is the first to open when you access the RTxxx's webpages. This gives the controller's hardware and firmware revision levels and the serial number. It also tells you the power being dissipated and the RTxxx's internal temperature.

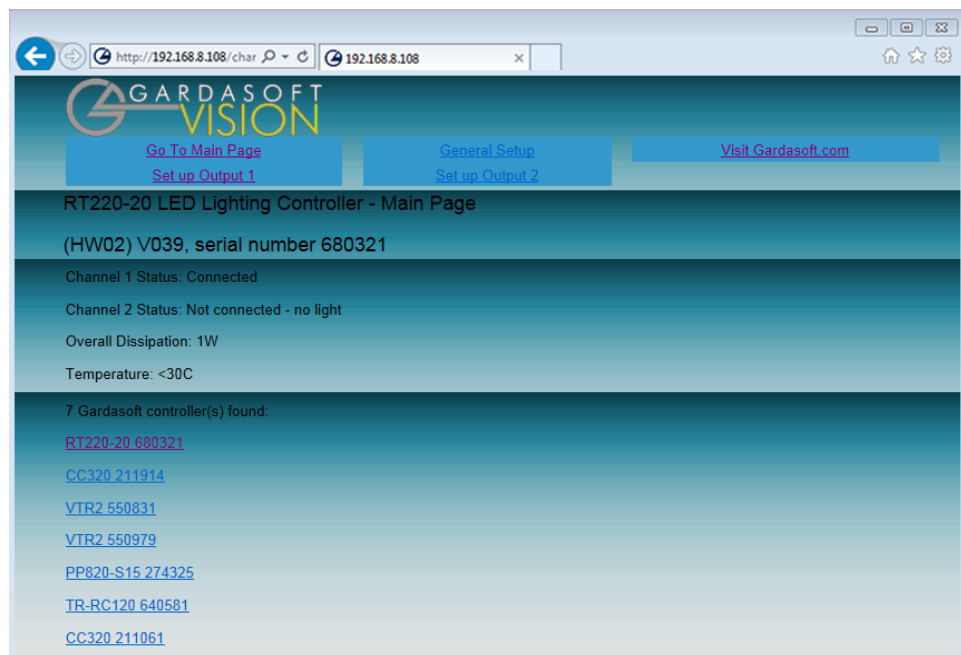

## 11.2 Configuration page

There is one configuration page for each output channel, as shown below. To refresh this page it is important that you click the **Refresh** button on the webpage(\*) rather than on your web browser. When configuration changes are submitted, the URL includes the new configuration, so refreshing the page re-submits the URL.

The screenshot shows a web browser window displaying the configuration page for an RT220-20 LED Lighting Controller. The page title is "RT220-20 LED Lighting Controller - Channel 1 Configuration (HW02) V039, serial number 680321". The configuration section includes fields for Mode (Continuous), Trigger (Trigger 1), Brightness (50.0%), Characterised up to (%), Brightness 2 (Selected Mode) (%), Pulse Delay (1.000ms), Pulse Width (1.000ms), Retrigger Delay (0.0us), and Flags (Error Detect, Pos Trigger, Autosense Enabled, Current adjust). A "Submit" button is located below the configuration fields. The Measurements section displays various parameters: Status (Connected), Dissipation (1.0W), Measured Current (0.244A), Supply Voltage (24.0V), SafePower(TM) Voltage (10.5V), Lighting Voltage (6.5V), Expected Voltage (0.0V), Voltage Drop (4.0V to 4.0V), Duty Cycle (100.0%), and Trigger Count (0, TRIG1 = 1). A "Refresh" button is located below the measurements section, marked with a red asterisk. The Lighting Rating section includes a field for Rating (0.500A) and an "Update" button.

You can set up all the parameters for each output channel. Pressing the **Submit** button updates the RTxxx configuration and saves the changes to non-volatile memory. On this page you can:

- » Change the current rating for the light.
- » View some measured voltages and the actual output current.
- » Set the output mode: continuous, pulsed, or switched.
- » Set the pulse parameters.

## 11.3 General setup page

The General Setup page allows you to set up or clear the webpage's password and set up the internal trigger. You can also enter any Ethernet command from Section 12, Command configuration.

The screenshot shows a web browser window with the URL `http://192.168.8.108/char`. The page header features the GARDASOFT VISION logo and navigation links: [Go To Main Page](#), [General Setup](#), and [Visit Gardasoft.com](#). Below the header, the page title is "RT220-20 LED Lighting Controller - General" with the hardware ID "(HW02) V039, serial number 680321". A link [Get help using this controller](#) is provided. The "Set Password" section contains two input fields for "Enter Password:" and "Repeat Password:", followed by a "Save" button. The "Internal Trigger" section has a dropdown menu for "Internal Trigger:" set to "Off", an input field for "Internal Trigger Period:" set to "100.0ms", and a "Save" button. The "Send Command" section includes an input field for "Enter command:", a "Previous output:" field showing ">>", and a "Send" button.

## 12 Command configuration

The RTxxx can be configured through the Ethernet connection using UDP or TCP/IP. You can download sample C++, C#, VB.NET code from [www.gardasoft.com](http://www.gardasoft.com) to allow configuration.

### 12.1 Ethernet configuration (RT220, RT420, RT820F)

For TCP, commands from a host should be sent to destination port 30313 with replies sent to destination port 30312. For UDP, commands from a host should be sent from source port 30312 to destination port 30313. Replies are sent from source port 30313 to destination port 30312.

A carriage return (ASCII 13) character should be sent to terminate the command line, in case multiple packets get joined together.

### 12.2 RS232 configuration (RT260, RT460, RT860F)

When using RS232 the COM port should be set to 115200 baud, 8 data bits, no parity, 1 stop bit, no handshaking.

A carriage return (ASCII 13) character should be sent to terminate the command line.

### 12.3 Command structure

Communication consists of commands sent by the host (controlling PC). All output generated by the command is returned in reply UDP or TCP/IP packets. The last character sent is > ('greater than' symbol). Once this is received, the host knows that the command has been completed.

We recommend that the host waits for the > symbol before sending the next command. UDP communications are not guaranteed to arrive, so the host software must be able to cope with lost messages.

Using the **GT** command, a host can request that a message is sent to it whenever an error occurs.

Several commands can be put into one command line by separating them by a semi-colon (;). The RTxxx sends any replies to the commands followed by a > character to show that the command line has completed.

All commands comprise a code of two letters followed by any optional parameters. All spaces in the commands are ignored.



Numeric parameters are separated by a comma ( , ). For a parameter which is a time period, the default units are milliseconds. 's', 'ms' or 'us' can be added to the end of the number to indicate seconds, milliseconds or microseconds. For currents, 'A' or 'mA' can be added to indicate amps or milliamps. The default unit is amps.

**Note:** parameters are in 'USA/UK' format so that a half is written '0.5' not '0,5'. For example:

Parameter	Meaning
0.1	0.1 millisecond
200µs	200 microseconds
0.1s	0.1seconds
100ma	100mA
2.45A	2.45A
2.3	2300mA or 2.3A

The command codes and their meaning are described in Section 12.3.1, General commands. The upper case commands are shown, followed by lower case letters denoting the numeric argument.

### 12.3.1 General commands

Any changes you make using Ethernet commands are not saved permanently until you send the **AW** command.

#### Report the version of firmware running in the RTxxx

This command returns the firmware version. For example:

**VR** returns

RT420-20 (HW02) V031

#### Set Internal Trigger

Enable or disable the internal trigger. When enabled, all outputs are triggered simultaneously using an internal trigger signal. This setting can be saved to non-volatile memory using the **AW** command.

- TT0** Disable internal trigger
- TT1** Enable internal trigger (uses previously set period)
- TT1,p** Enable internal trigger and set the period

Where:

**p** = period of the triggers in milliseconds

For example:

TT1, 200 Set the internal trigger to 200ms (5Hz)

TT1, 500US Set the internal trigger to 500µs (2KHz)

### Save the settings to memory

#### **AW**

Once the settings are saved to memory they are retained when the unit is switched off. If this is not done, changes to the settings are volatile, and if the unit is switched off they revert to those in force when the last **AW** command was issued.

### Clear Configuration

#### **CL**

Clears the channel configuration and lighting ratings and sets all channels to 50% continuous operation. The results of the **VL**, **RS**, **RW**, **RU**, **RT**, **RE**, **RP**, **TT**, and **AW** commands are all cleared.

### Show Configuration

#### **ST**

This command shows the operational parameters for all channels in the controller. A typical output for an RT220 controller is:

```
CH1,MD0,S50.0,0.0,DL1.000ms,PU1.000ms,RT0.0us,IP1,FL0,CS0.000A,RA0.000A
```

```
CH2,MD0,S50.0,0.0,DL1.000ms,PU1.000ms,RT0.0us,IP2,FL0,CS0.000A,RA0.000
```

Where:

CH	Channel number
MD	Mode: 0 = continuous, 1 = pulse, 2 = switched, 3 = select
S	Brightness percentage settings: 1st setting used in all modes 2nd setting only used for select mode
DL	Pulse delay
PU	Pulse width
RT	Retrigger delay

IP	Input trigger (set using the <b>RP</b> command)
FL	Flags (set using the <b>RE</b> command)
CS	Rating of the light (after SafeSense has successfully completed sensing the light)
RA	Rating of the light (set using the <b>VL</b> command).

When using Ethernet, use the following forms of the **ST** command:

### **STO**

Reports the general settings. A typical output is:

```
TM 1, TP 20.00ms
```

### **STc**

Where:

**c** = the input channel (1 to 2, 4, or 8 depending on model).

This reports the settings for a single channel.

## **Simulate an Input Trigger**

### **TRc**

Where:

**c** = the input channel (1 to 2,4 or 8, depending on model).

This simulates a trigger pulse. If the channel is in pulse mode it pulses the output once.

## **Enable Ethernet Messages**

### **GTm**

Where:

**m** = 0 to disable Ethernet messages, or

**m** = 1 to enable Ethernet messages.

When Ethernet messages are enabled, any error reports are sent to the most recent UDP or TCP address from which a command has been received. Messages are of the form:

```
Evtc,e
```

Where:

**c** = the channel number (1 to 2,4 or 8), or 0 for no channel

**e** = event value (see [Section 13.5, Event codes](#)).

## Clear any Errors

### GR

If Ethernet messages are not enabled, the last event or error number can be read by this command. Any error displayed on the unit is cleared, so if there was a lighting error, the RTxxx resumes auto-sensing on that channel.

The reply is in the same form as the **GT** command above. If there are no outstanding events or errors, then only the prompt > is returned.

## Set/Clear the Webpage Password

### EY

#### EY asc1, asc2, asc3, asc4, asc5, asc6

This command sets the password required to access the webpages. If **EY** is entered on its own then the password is cleared. There are six optional parameters, which are decimal ASCII values for a password from one to six letters. A value of 65 is 'A', 66 is 'B', and so on, to 90 is 'Z'.

You can set an unlock code. This can be used as a low-security way of allowing trusted users to unlock the keypad. Ethernet commands and the web pages still work. The setting of this command is restored after a power cycle.

## 12.3.2 Lighting channel commands

### Set the rating of a light

This command sets the current or voltage rating for a light. If a current rating is being set, then the voltage rating value should be 0.

#### VLo,v,c

Where:

**o** = output channel (1 to 2, 4 or 8, depending on model)

**v** = voltage rating (0 or 12 to 36)

**c** = current rating (0 or 10mA to 3A)

### Set automatic sensing of lighting characteristics

This command sets the maximum brightness to be used when automatically sensing the characteristics of the light connected.

#### PQc,0

#### PQc,m

## **PQ**

Where:

**c** = output channel (1 to 2,4 or 8, depending on model)

**m** - maximum expected brightness (50% to 999%)

Setting **m** = 0 turns off automatic sensing. The **PQ** command returns the current maximum brightness for automatic sensing.

### **Set continuous mode**

The output is set to continuous mode at a percentage of full brightness.

#### **RSc,s**

Where:

**c** = output channel (1 to 2, 4 or 8, depending on model)

**s** = setting in percent (s = 0 to 100)

### **Set switched mode**

The output is set to switched mode at a percentage of full brightness.

#### **RWc,s,w,r**

Where:

**c** = output channel (1 to 2, 4 or 8 depending on model)

**s** = setting in percent (s = 0 to 100)

**w** = typical pulse width in ms (optional)

**r** = likely period in ms (optional)

The **w** and **r** parameters are optional and should only be used when the expected pulse width is >100ms and/or the period is >5 seconds. **w/r** gives the expected duty cycle.

### **Set selected mode**

The output is set to selected mode with two brightness settings.

#### **RUc,s,t**

Where:

**c** = output channel (1 to 2, 4 or 8, depending on model)

**s** = brightness 1 setting in percent (s = 0 to 100)

**t** = brightness 2 setting in percent (t = 0 to s)

## Set pulse mode

The output can be set up to pulse on a trigger input. The delay from trigger to the start of the pulse, the length of the pulse and the brightness are configurable.

An error is generated if the brightness setting requires a current greater than 20A or if the combination of pulse width and setting is not allowed.

**RTc,p,d,s**

**RTc,p,d,s,r**

Where:

**c** = output channel (1 to 2, 4 or 8, depending on model)

**p** = pulse width in milliseconds (0.02 to 999)

**d** = delay from trigger to pulse in milliseconds (0.02 to 999)

**s** = setting in percent (s = 0 to 999)

**r** = retrigger delay. This parameter is optional.

## Set the Option Flags

**REc,m**

Where:

**c** = output channel (1 to 2, 4 or 8, depending on model)

**m** = flags:

bit 1 = 0 E flag set (error detection enabled)  
1 E flag cleared (error detection disabled)

bit 2 = 0 P flag set (positive triggers)  
1 P flag cleared (negative triggers)

bit 3 = 0 Autosense set (controller waits for light to be connected)  
1 No Autosense (controller assumes light is connected)

bit 6 = 0 Enable current adjust  
1 Disable current adjust

**Note:** Bit 0 is the least significant bit.

## Set the Trigger Input

This command sets which input is used for pulse and switch output modes.

### RPC,p

Where:

**c** = output channel (1 to 2, 4 or 8, depending on model)

**p** = trigger input (1 or 2)

This command can be used to override the state of an input. The override is cancelled as soon as an edge is detected on the input.

### 12.3.3 Command summary

Command	Example	Effect
<b>AW</b>	AW	Save changes.
<b>CL</b>	CL	Clear configuration.
<b>GT</b>	GT1	Enable Ethernet messages.
<b>GR</b>	GR	Clear any error conditions
<b>EY</b>	EY65,66	Set webpage password to 'AB'.
<b>VR</b>	VR	Read the firmware version.
<b>VL</b>	VL1,0,0.5	Set the rating of channel 1 to 0.5A.
<b>RS</b>	RS2,65	Set channel 2 to 65% brightness continuous.
<b>RW</b>	RW1,50	Set channel 1 to 50% switch mode.
<b>RU</b>	RU1,75,25	Set channel 1 to selected mode at 75% and 25%.
<b>RT</b>	RT2,3,4,50	Set channel 2 to 3ms pulses, delayed by 4ms at 50% brightness.
<b>RP</b>	RP1,2	Output channel 1 is triggered using output 2
<b>RE</b>	RE1,3	Set channel 1 to ignore lighting errors and not prompt for the current rating of a light when it is connected.
<b>TT</b>	TT1,1ms	Set internal triggers every 1ms.

<b>Command</b>	<b>Example</b>	<b>Effect</b>
<b>TR</b>	TR2	Trigger channel 2.
<b>ST</b>	ST2	Show configuration for channel 2.



## 13 Reference information

This section contains the specification for the RTxxx and any restrictions on its use. Error and event codes are also listed.

### 13.1 Specification

The RTxxx range of controllers has a 2 amp option with a '-2' suffix, and a fast pulsing option with an 'F' suffix. The specification for these is shown below alongside standard versions.

	RTxxx-20	RTxxx-2
Each output channel	3A maximum continuous / 20A pulsed, 46V output and 30W average output power*	2A maximum continuous / 2A pulsed, 46V output and 30W average output power*
Lighting rating	12V to 36V in steps of 1V 100mA to 3A in steps of 5mA	12V to 36V in steps of 1V 100mA to 2A in steps of 1mA
Operating modes	Continuous, strobe, switch, and selected	
Trigger input	Opto-isolated, standard or inverted operation 3V to 24V	
Pulse width: (RT2xx, RT4xx)	20 microseconds to 1 second. Repeatability to 0.1 microseconds.	
Pulse width: (RT2xxF, RT4xxF, RT8xxF)	1 microsecond to 1 second. Repeatability to 0.1 microseconds.	
Trigger delay: (RT2xx, RT4xx)	20 microseconds to 1 second. Repeatability to 2 microseconds.	
Trigger delay: (RT2xxF, RT4xxF, RT8xxF)	2 microseconds to 1 second. Repeatability to 2 microseconds.	
Maximum trigger rate	1kHz for pulses > 150 microseconds	
Internal trigger timer	0.2Hz to 1kHz	
Supply voltage	24VDC to 48VDC regulated	
Heat dissipation	10W maximum	

\*Refer to Section 13.2, Restrictions

## 13.2 Restrictions

The maximum output power for an RT2xx is 30W per channel or 40W total. For an RT4xx, it's 30W per channel or 50W total. The maximum output power for an RT8xxF is 30W per channel or 100W total.

The following timings and restrictions are applied whenever settings are saved (using the **AW** command).

### » B.1 Continuous Mode

The maximum output current is 3A (2A for an RTxxx-2).

### » B.2 Switched Mode

The maximum delay from a trigger input changing to the output current being turned on or off is 10 $\mu$ s. The maximum output current is 20A (2A for an RTxxx-2).

### » B.3 Selected Mode

The maximum delay from a trigger input changing to the output current being turned on or off is 5ms. The maximum output current is 0.5A.

### » B.4 Pulse Mode

The maximum output current is 20A (2A for an RTxxx-2). For high current pulses the following limits apply:

Pulse current	Pulse length limit
20A	100 $\mu$ s
12A	400 $\mu$ s
10A	1ms
5A	3ms

Pulses of 2A or more for pulse widths longer than 2ms may cause an error or have a lower current towards the end of the pulse:

For fast pulse controllers (RTxxxF) the minimum pulse delay is about 2 $\mu$ s. When overdriving or using the retrigger delay, the minimum delay is around 5 $\mu$ s.

For pulse widths less than approximately 150 $\mu$ s, the output voltage and current cannot be measured. Because of this, fault detection is disabled and the following restrictions apply:

For pulse currents greater than 0.5A, the duty cycle is restricted to 1%.

For pulse currents less than or equal to 0.5A, the duty cycle is restricted to 10%.

**Special note for RT8xxF controllers:** If you need to generate a variety of output currents, the highest current loads should be connected to the low-numbered output channels. For example CH1, CH2... This minimises the spread of high currents on the internal PCB and helps to maintain a low temperature rise in the unit.

### 13.3 Error codes

Error number	Reason
Err 1	A parameter value is invalid.
Err 2	Command not recognised.
Err 3	Numeric value is the wrong format.
Err 4	Wrong number of parameters.
Err 5	This is a warning, not an error. One of the parameters is out of range. The value of the parameter has been adjusted. For example, sending an <b>RT</b> command with a delay of 0 gets a reply of 'Err 5'. The command is accepted but the delay is set to the minimum allowed value.
Err 19	A light has been connected to a channel but no rating has been set.
Err 8, 12	EEPROM corrupt. The configuration has been cleared.
Err 9, 20	Could not save settings to EEPROM.
Err 21, 22, 23	Sensing error. See Section 6.2, Light auto-sensing.
Err 27	Unable to read Ethernet settings from EEPROM; they may be incorrect.
Err 34, 47	Internal power dissipation is too high. Output turned off.
Err 35	Output current to lighting is too low.
Err 43	The requested output current requires too high a voltage.

Error number	Reason
Err 36	The output is short circuit.
Err 42	The output current is too high.
Err 37	The voltage required for the lighting has increased too much. Check for ageing of the lighting or a failed LED.
Err 38	The voltage required for the lighting has decreased too much. Check for ageing of the lighting or a failed LED.
Err 39	Internal protection has prevented SafePower voltage going too high.

### 13.4 Fatal error codes

Error number	Reason
Err 44	The RTxxx is too hot. The RTxxx has a thermal cutout which operates around 65°C to 70°C, depending on conditions.
Err 40, Err 41 Err 45	One channel is outputting more current than expected.
Err 46	One channel is dissipating more than 30W.
Err 47	Internal protection has prevented too much heat in the output driver.

### 13.5 Event codes

Event messages are sent when a light is connected or an error occurs. The format of these is:

**Evt<channel>,<event code>;**

These event messages are only sent after the **GT1** command has been sent.

Event number	Reason
1 to 127	An error has occurred. The error code is given by the event number.

Event number	Reason
128	A light has been connected and is working.
129	A light has been connected but doesn't have a current or voltage rating.
130	An over temperature error occurred.
131	An over current error occurred.
132	An error has occurred while autosensing the rating of a light.
138	SafePower trainup has completed.
139	SafePower trainup has failed or been cancelled.
140	In switch output mode, the light has been turned off because the duty cycle is too high.

Issue v015 - August 2020

© Copyright 2020 Gardasoft Vision Ltd

Gardasoft LLC  
Oak Ridge Road  
Weare  
New Hampshire  
03281 USA  
tel: +1 603-657-9026

Gardasoft Vision Ltd  
Trinity Court  
Buckingway Business Park  
Cambridge CB24 4UQ UK  
tel: +44 1954 234970