

USER MANUAL



RC100, RC120 **LED Lighting Controller** Revision 001

Gardasoft Vision Ltd Trinity Court Buckingway Business Park Cambridge, CB24 4UQ UK	Gardasoft LLC Oak Ridge Rd Weare, NH 03281 USA
--	---

Web: www.gardasoft.com

1 Disclaimer

Except as prohibited by law:

- Hardware, software and documentation are provided on an “as is” basis.
- It is essential that the user ensures that the operation of the product is suitable for their application.
- The user must ensure that incorrect functioning of this equipment cannot cause any dangerous situation or significant financial loss to occur.
- Gardasoft Vision Ltd and Gardasoft Products Ltd do not accept any liability for consequential loss of any kind.

All trademarks acknowledged. Hardware, software and documentation are Copyright 2002 – 2014 Gardasoft Products Ltd. Hardware manufactured by Gardasoft Vision Ltd under licence.

2 Getting Started

Read Section 3: Safety, and Specifications (Appendix A) and check the RC1XX fulfils your requirements. See the back cover for other Gardasoft Vision lighting products.

Mount the RC1XX as described in Section 4.

Connect the RC1XX up to a power supply as described in Section 5: Connections. When the front panel is present, the RC1XX shows two alternating lines on the display to indicate that it is operating normally.

Read section 7 on Lighting Setup, enter the current or voltage rating of the lights to be connected and then connect the lights. Set up the RC1XX for the desired operation as described in the configuration sections 8, 10 and 11.

Visit www.gardasoft.com for application notes on this product. There is also a Support page which has information on troubleshooting problems.

The RC1XX may emit a slight noise when operating.

2.1.1 RC100 and RC120:

Throughout this manual, references to RC1XX refer to both the RC100 and RC120.

The following table lists the differences between the models.

	Number of channels	Front panel configuration	Ethernet configuration	Max current output (continuous)	Max current output (pulsed)
RC100	1	Yes	No	1A	1A
RC120	1	Yes	Yes	1.2A	2A

3 Safety

Read this before using the RC1XX. Always observe the following safety precautions. If in doubt, contact your distributor or Gardasoft Vision. The following symbols mean:

 Warning: read instructions to understand possible hazard

 Warning: Surface may get hot

Where these symbols appear in the manual, refer to the text for precautions to be taken.

3.1 Heat

Read Section 4: Mounting.

Do not exceed the power ratings given in the manual.

Note: At the maximum ratings the case temperature can reach 65°C.

Allow free flow of air around the unit.

3.2 Electrical

The RC1XX does not have complete tracking isolation of inputs and outputs.

Transients caused by inductive loads must be suppressed external to the RC1XX.

The RC1XX outputs high energy pulses. Care must be taken to connect the outputs correctly and protect the output wiring and load from inadvertent short-circuits. When switched off, there is still energy stored in the RC1XX for about 15 seconds.

3.3 General

The RC1XX must not be used in an application where its failure could cause a danger to personal health or damage to other equipment.

If the equipment is used in a manner not specified by the manufacturer, the protection provided by the equipment may be impaired.

Cleaning: Unit must be switched off. Wipe with a cloth dampened with water and detergent. No solvents or other cleaning agents to be used.

4 Mounting

The RC1XX is designed to be mounted on a DIN rail.

4.1 Environmental considerations

Mount the unit vertically or horizontally on the DIN rail to allow the display to be easily read.

 When the average power output is more than 15W (see section on Operation) the RC1XX should be mounted in the orientation shown below such that air can move vertically through the controller.

The RC1XX has an ingress rating of IP20 and should be mounted so that moisture and dirt cannot enter the unit.

Dimensions:

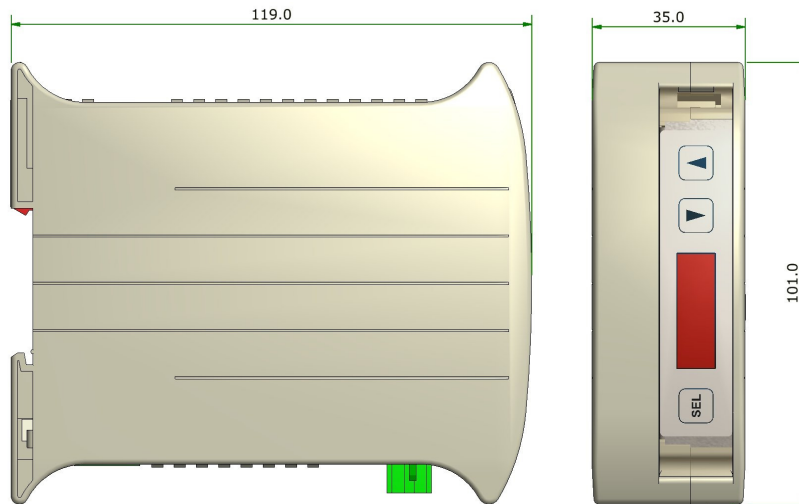

Connectors:



Ethernet (RC120 only)

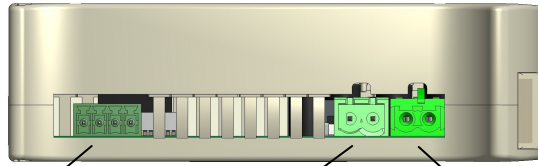

Trigger Input

Power Supply Input

Lighting Output

5 Connections

See the Specification (Appendix A) for information on RC1XX ratings.

5.1 Power Supply



Any power supply derived from the mains must have a SELV output.

The power supply input is fused internally with a non-replaceable fuse.

All low voltage wiring to the RC1xx should be routed separately from mains wiring. If they must be loomed together ensure that low voltage insulation rating is sufficient or that supplementary insulation is used.

Pin	Power Input Connector
1	+24V +/-10%
2	GND

5.2 Lighting Output

Make sure you set the current or voltage rating for a light before connecting it. See the Lighting Setup (Section 7) for details on this.

Light output is on 2-way pluggable screw terminal socket.

The lighting output connections must not be commoned to any other controllers or grounded in any way.

Pin	Output Connector
1	Lighting output +ve
2	Lighting output -ve This connection is not connected to GND.

5.3 Trigger Input

The trigger input is a Smart Input. This is designed to handle a range of trigger sources with minimal extra circuitry. The connections are:

Pin	Trigger connector
1	No connect
2	No connect
3	+VE (Smart trigger input)
4	GND

Note that the Smart Input is not isolated, it is ground-referenced to the power supply negative connection.

The Smart Input can be connected to the following types of signal.

3V to 24V voltage source

A voltage signal of 0V to 0.9V will be taken as a logic 0. A voltage signal of 3V to 24V will be taken as a logic 1.

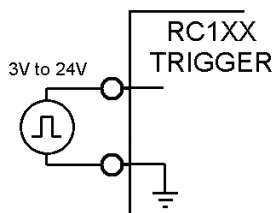

TTL Signal

A TTL signal can be connected to the input. 5V TTL signals will always work. A 3.3V TTL signal will work as long as the signal can drive 50kohm up to 2.7V.

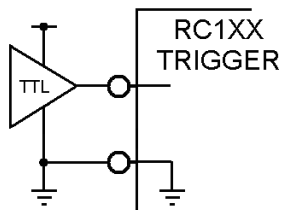

NPN Signal

An NPN open collector drive can be connected to the input using the following connections.

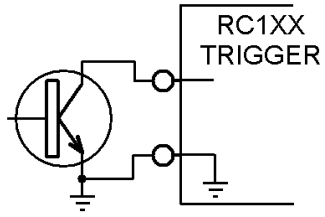

Opto-coupler

Connected as follows this works as an NPN drive. This would be the preferred method for preventing a 'ground loop', or for reducing spurious triggering in a high-interference environment.

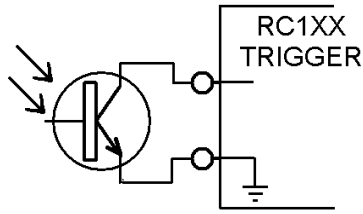

PNP Signal

A PNP open collector drive can be connected to the input using the following connections. The PNP transistor should not pull up to more than 24V.

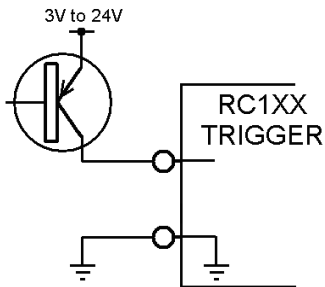

5.3 Ethernet Connection (RC120)

The RJ45 Ethernet connector requires a straight-through cable to connect into a network switch, hub or router. It operates at 10Mbits per second (10Base-T).

5.4 Connectors

The RC1XX packaging includes mating connectors for the power supply input, trigger inputs, and lighting output.

Should spare parts be required these can be obtained as follows:

Connector	Description	Wuerth part number <small>www.we-online.com</small>	Farnell part number <small>www.farnell.com</small>
Power Input	Wuerth 351 series 2W screw terminal free socket	691351500002	1641952
Trigger Input	Wuerth 361 series 4W screw terminal free socket	691361100004	1841351
Lighting Output	Wuerth 348 series 2W screw terminal free plug	691348500002	N/A

6 General Description

The RC1XX current controller provides repeatable control of LED lighting for machine vision applications. It includes the intensity control, timing and triggering functions required for machine vision systems.

LED lighting needs a constant current supply as small variations in voltage can cause large variations in light output. The RC1XX can set currents in steps of 0.1% (with a lower limit of 2.5mA steps) to give very fine control of intensity.

Several modes of operation are separately available:

- **Continuous** (“SCo”):

In continuous mode the output is a continuous brightness.

- **Pulse (Strobe)** (“SPu”):

In pulse mode output is pulsed once per trigger. One trigger input is used as a trigger. The delay from trigger to pulse, the pulse duration and the brightness can be set.

- **Switched** (“SOn”):

In switched mode a trigger input is used to switch the output current on and off.

The RC1XX is set up using the push buttons and display on the front of the unit. The set up is non-volatile, so the RC1XX resumes the same operation after a power cycle.

6.1 SafeSense™

SafeSense™ is a technology unique to Gardasoft controllers. SafeSense works by using the following techniques:

Lighting detection

Determination of current rating

Safe driving of lighting

Detection of faults

SafeSense™ operates automatically; it is only noticeable during initialisation, when it first detects the light and then safely and accurately senses its type and characteristics. Once configured and initialised, the unit does not need to sense the light again until power-cycled or if the light rating is changed.

For further information, see the following application note on our website www.gardasoft.com

APP936 – SafeSense™ Technology

6.2 SafePower™

Gardasoft's RC LED Lighting Controllers also have SafePower™ technology. SafePower™ requires no user intervention and gives the following advantages:

Heat dissipation in the controller is very low

The load voltage can be higher than the supply voltage

High continuous currents can be output without heatsinking the controller

For further information, see the following application note on our website www.gardasoft.com

APP966 – SafePower™ Technology

6.3 Output Modes

6.3.1 Continuous Mode

In continuous mode the output current is fixed and continuous.

The output current can be varied from 0% to 100% of full brightness.

6.3.2 Pulse Mode

The output is off by default. When the RC1XX is triggered it waits for a delay and then pulses the output. The delay, pulse width, retrigger delay and pulse intensity are all configurable.

In pulsed mode, the brightness can be set up to 1000% of its rating, but only for short periods and at low duty cycles so that the lighting does not overheat and get damaged. The duty cycle will be internally limited by ignoring triggers which are too soon after the previous trigger.

Output Brightness	Maximum Pulse Width	Maximum Duty Cycle
0 to 100%	100ms	100%
101% to 200%	30ms	30%
201% to 300%	10ms	20%
301% to 500%	2ms	10%
501% to 1000%	1ms	5%

So for example, if the brightness is set to 250%, then the RC1XX does not allow pulses greater than 10ms long. With 10ms pulses, if a trigger occurs within 50ms of a previous trigger (so that the duty cycle would be greater than 20%) the trigger is ignored.

The retrigger delay is the minimum allowed time from one trigger to the next. Any triggers that happen too soon after the previous trigger are ignored. The retrigger delay is set in multiples of 100us. The retrigger delay is the maximum of:

$$\begin{aligned} & \text{User configured retrigger time} \\ & \text{Delay + pulse width} \\ & 100 * [\text{pulse width}] / [\text{max duty cycle percentage}] \end{aligned}$$

The last expression is the limit which ensures that the maximum duty cycle cannot be exceeded when overdriving.

6.3.3 Switched Mode

Switched mode uses the trigger input to switch the output on or off. The output follows the input signal state. It can be inverted (see below).

Switched mode can be used to drive the light at up to 1000% brightness for short periods. It has the same limits as pulse mode.

6.4 Triggers

The RC1XX has a Universal trigger input trigger input, active high or active low.

The P flag (set using the front panel, webpages or the RE command) sets whether an input is used active high or active low.

The trigger inputs are used as follows:

Mode	P Flag	Output
Continuous	Unused	Output is on.
Switched	P Flag = 1	Output is off when trigger is off Output is on when trigger is on
	P Flag = 0	Output is on when trigger is off Output is off when trigger is on
Pulsed	P Flag = 1	Pulse is triggered on rising edge
	P Flag = 0	Pulse is triggered on falling edge

Note that the P flag inverts the sense of the trigger input.

Normally it is necessary to synchronize pulsing to an external camera signal. However there is an internal trigger which can be used to generate regular triggers. The period of the internal trigger can be set in steps of 100us from 10ms upwards.

There is a command TR1 and a webpage **Trigger** button to produce a single pulse for testing.

6.5 Flags

Flags (true or false values) are available for changing the operation of each output. These can be set using the front panel keypad, webpage configuration or the RE command.

The following configuration flags are available:

E Flag

This enables or disables fault detection (see next section). The default setting is that error checking is enabled.

P Flag

This specifies whether the trigger input is active high or active low. The default is active high.

When a trigger is active high:

- in pulse mode pulses are triggered by the rising edge of a trigger pulse
- in switched mode the light is on when the trigger input is high

When a trigger is active low:

- in pulse mode pulses are triggered by the falling edge of a trigger pulse
- in switched mode the light is on when the trigger input is low

S Flag

When this flag is cleared it removes the SafeSense™ light detection so that the controller always assumes a light is connected. This cannot be used with a voltage rating. The default is for SafeSense™ to be enabled.

This flag cannot be controlled using the keypad.

6.6 Fault Detection

The RC1XX detects the following errors. When the output current is less than 100mA, some fault detection is disabled.

Error	Reason
PO	Internal power dissipation is too high. Output turned off.
OP	Output current to lighting is too low. The light is open circuit or there is not enough supply voltage for the requested output current.
SH	If the output voltage is too low, the controller detects that the output is short circuited.
HI	The voltage required for the lighting has increased too much. Check for ageing of the lighting or a failed LED.
LO	The voltage required for the lighting has decreased too much. Check for ageing of the lighting or a failed LED.

The user presses SEL to cancel the error and the RC1XX re-senses the light.

6.7 Cold Start

The RC1XX configuration can be cleared to its default settings - this clears the lighting rating and sets the output to 50% brightness, continuous operation. This can be done from the front panel or by sending the CL command using Ethernet.

To clear the configuration from the front panel, turn on the RC1XX while holding the SEL and DOWN buttons, for about 5 seconds, until 'COL' is displayed. The controller can be cold booted when the keypad is locked. The lock is removed by the cold boot.

7 Lighting Setup

Lighting is labelled with either a voltage or current rating. This rating is the supply to the lighting that should be used to get 100% continuous brightness from the light.

The RC1XX is compatible with both current and voltage rated lighting.

Before connecting a light the rating of the light must be entered. If a light is replaced with a different type of light, then the rating must be set first. If a light is replaced with the same type of light then the previous rating still applies.

Consult the specification or labelling for the light. For commercially available lighting modules, if a voltage and current rating is given, it is usually correct to use the voltage rating. If a voltage and wattage rating is given, use the voltage rating. Otherwise use the current rating. In all cases the light is still driven with a constant current. For unrated lights using single LEDs or arrays of LEDs use the current rating from the LED datasheet.

The current rating can be set from 0.01A to 1A (RC100) or 2A (RC120) in steps of 0.01A. The voltage rating can be set from 12V to 24V in steps of 1V.

When a voltage rated light is connected, the RC1XX automatically senses the current rating of the light.

Voltage and current rated lights are both driven with a constant current. This gives better brightness stability and allows the RC1XX to prevent the light being driven with too much power.

7.1 Setting the Rating for a Light

To set the rating of a light on the RC120, use the VL command or the internal webpages.

To set the rating of a light from the front panel, press and hold the SEL button for 1 second. The display shows "CH1". Press DOWN to show "rAt" then press SEL. Then press SEL and select "Cur" for current rated lights and "UoI" for voltage rated lights. Then press SEL and set the current. Press SEL to save the rating.

Press and hold SEL for 1 second, select "rAt" and then select CH1

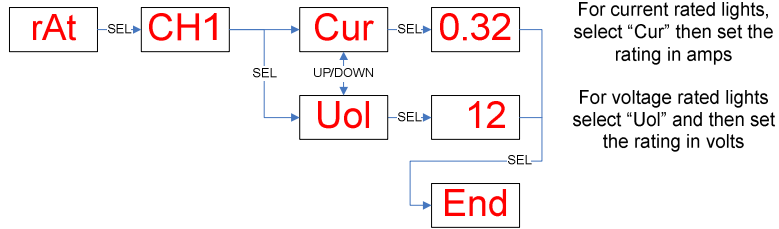

7.2 Light Auto-Sensing

When the RC1XX does not have a light connected, SafeSense™ continually tries to put out a very small current.

When a light is connected, it flashes for a short time (the light is not damaged by this) until the RC1XX detects that it is connected.

For voltage rated lights the light is briefly driven at an increasing current until 100% output is achieved in order to sense the current rating of the light. This can generate the following errors:

Display Error	Comms Error Number	Reason
E 1	Err 21	Current output is too low. This may be caused if the light becomes disconnected.
E 2	Err 22	The lighting requires more than maximum available current for the voltage rating.
E 3	Err 23	Current output is not what was expected. The controller might need re-calibrating.
E 6	Err 23	The power rating of the light exceeds the maximum power rating.

Errors may be cleared by pressing SEL on an RC100 or RC120, or sending the GR command on an RC120 (see section 11.2.1).

8 Front Panel Configuration

8.1 Startup

For controllers with a front panel, on power up, the RC1XX displays "b r" for 5 seconds followed by '8.8.8.' to show that the display is working, then 'RC1', then '00', followed by the firmware version number, e.g. '001', and then is ready for operation. To show that the unit is operating normally, an alternating pattern is drawn on the display. When lights are connected, the controller uses SafeSense™ to automatically sense the light.

Note: If light(s) are connected and no rating is specified then an error is indicated. To set the rating, refer to section 7.1.

The overall structure of configuration is given to the right.

To configure the controller from the keypad, press and hold SEL for 1 second. 'CH1' is displayed. Use UP and DOWN to select which feature to set up.

Pressing and holding MODE at any time cancels the operation.

Using the keypad it is possible to set the configuration, set a keylock code so that unauthorised users cannot change any settings, set the internal trigger timer, view trigger status and set the voltage or current rating.

8.2 Setting the Lighting Rating

This is described in Lighting Setup (Section 7).

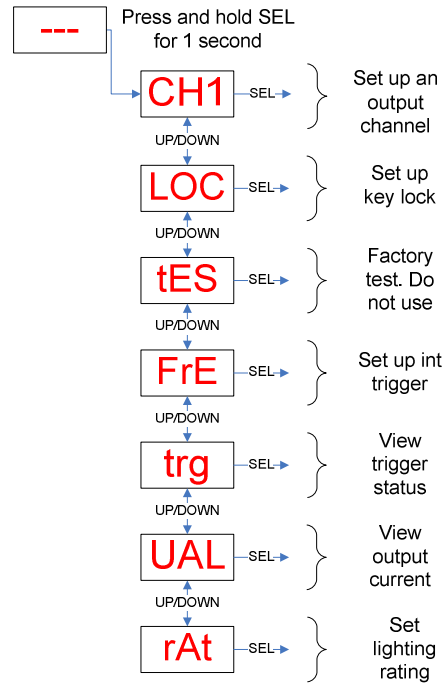

8.3 Default Display

When the RC1XX is not being configured the display shows the status of the lighting output. The segments and their meanings are given below.

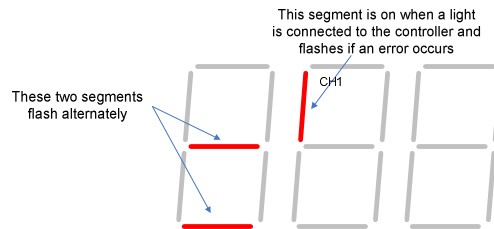

Errors are usually caused by a light being connected but the rating for that light has not been set. The rating of a light can be set as described in Section 7.1.

8.4 Setting Flags

The polarity of the trigger signal (P flag) can be set for some output modes and error checking (E flag) can be disabled. During configuration the user is able to select from the following flags:

- F E Error checking enabled
- F - E Error checking disabled
- F P Trigger is active high
- F - P Trigger is active low

8.5 Setting Up Continuous Output

Continuous output is set up as follows. Select "SCo" for continuous operation.

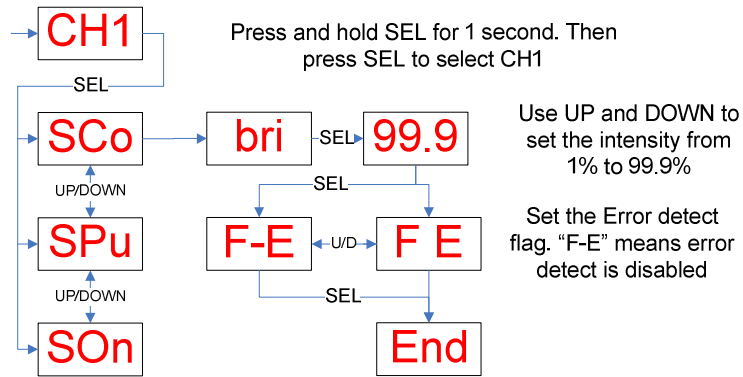

8.6 Setting Up Switched Output

Switched output is set up as follows. Select "SOn" for switched operation.

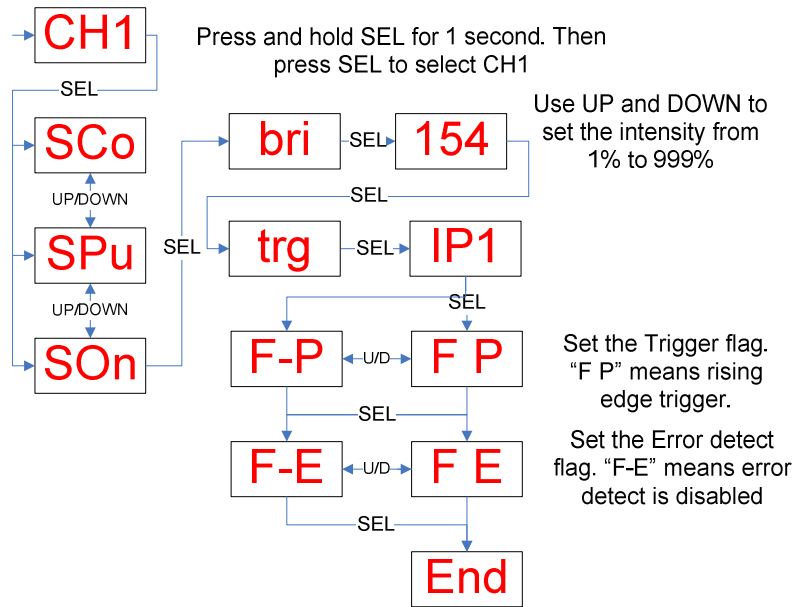

8.7 Setting Up Pulsed Operation

Pulsed operation is set up as follows. If the selected brightness is greater than 100% then the pulse width is limited to a safe value as described in Section 6.3.2.

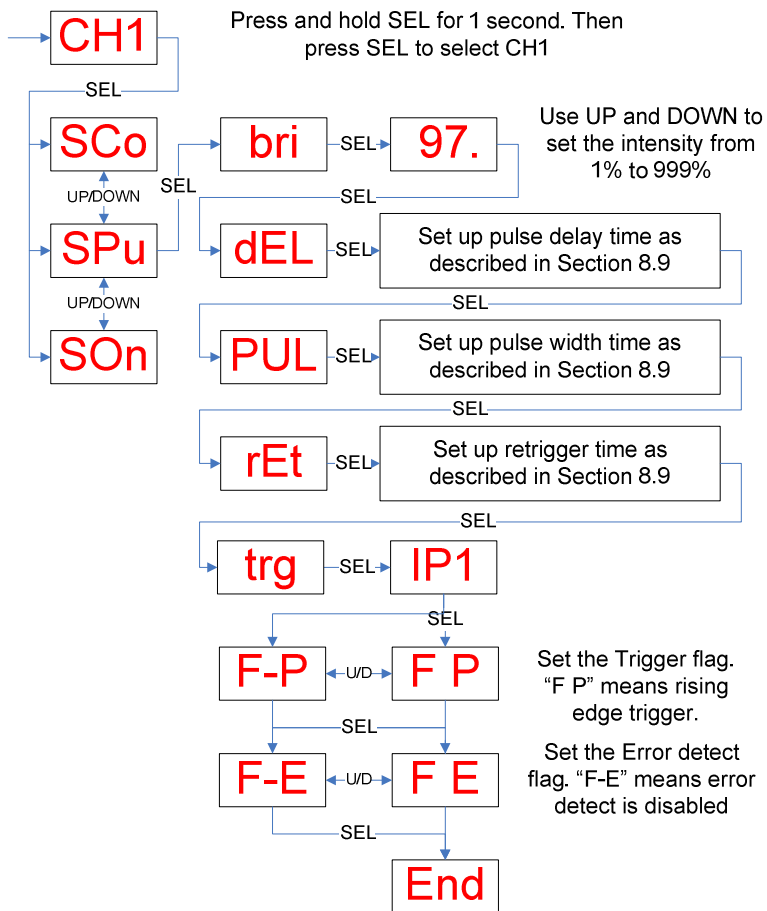

8.8 Setting Pulse Delay and Width Times

When the RC1XX displays numeric values for the user to change, the right hand digit flashes to indicate that the Up and Down buttons can be used to change the value.

To be able to set pulse delay and pulse width values a scheme is used where the exponent (power of ten) of the value is set. The exponent values are as follows:

Exp value	Number format	Range of values
E-2	9.99	Values are displayed in seconds from 10ms to 5 seconds in steps of 10ms.
E-3	999.	Values are displayed in milliseconds from 1ms to 999ms in steps of 1ms.
E-4	99.9	Values are displayed in milliseconds from 0.1ms to 99.9ms in steps of 0.1ms.

The flow diagram for entering timings on the keypad is given below.



When a light is pulsed, the display shows that a trigger has occurred by showing 'PUL' on the display.

8.9 Setting the Internal Trigger Timer

An internal timer is available for triggering in pulse mode. When this timer is turned on, the unit will trigger if in pulse mode. The delay and pulse width is the same as for external triggers. External triggers remain enabled.

The period of the timer (the time between triggers) is set as follows.

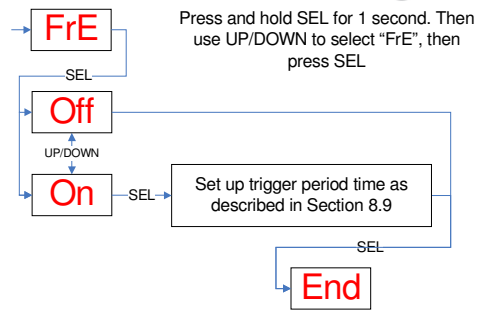

8.10 Key Lock

The keypad can be locked so that unauthorised users cannot change the configuration. This can be by setting a lock code. Users who know the lock code can unlock the keypad. The lock code is from 0 to 255, providing moderate protection. The lock code is entered by using the UP/DOWN buttons to change this number.

The lock code does not prevent a cold boot. Cold boot clears the lock code.

Unlocking the keypad

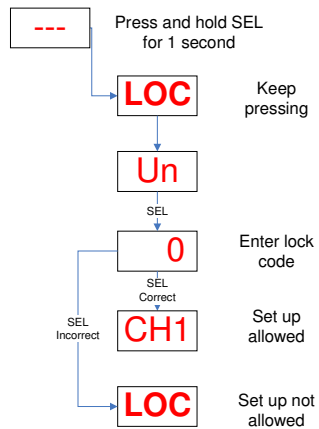

Locking the keypad

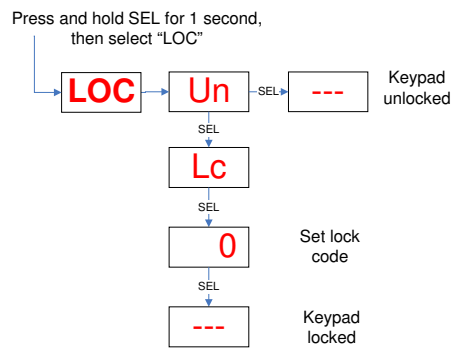

8.11 Viewing Trigger Status

When the unit is in pulse mode, it is possible to view the trigger input status and whether the light is pulsing. To enter this mode, press and hold SEL for 1 second. Then use UP/DOWN to select "trg" then press SEL. The following display is shown. Press SEL to cancel this display.

This trigger display works for pulse and switch modes. 'High' trigger is when the trigger input voltage is 3V or more, 'Low' means it is less than 0.5V.

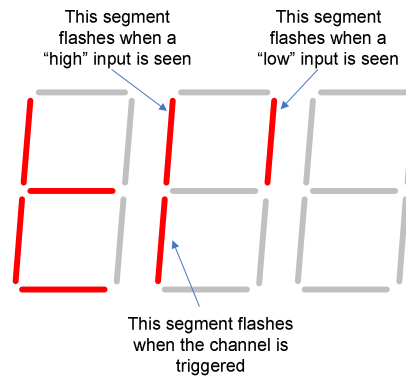

8.12 View Output Current

An approximate measure of the output current can be viewed from the keypad. The current is updated approximately every second, but can be slower for pulse mode.

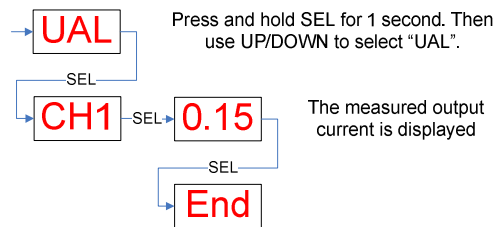

9 Ethernet Communication (RC120)

You may need to ask your network administrator for advice about setting up the Ethernet connection.

Download GardasoftMaint from the RC1XX software downloads at www.gardasoft.com. This program allows the IP addresses of controllers to be managed.

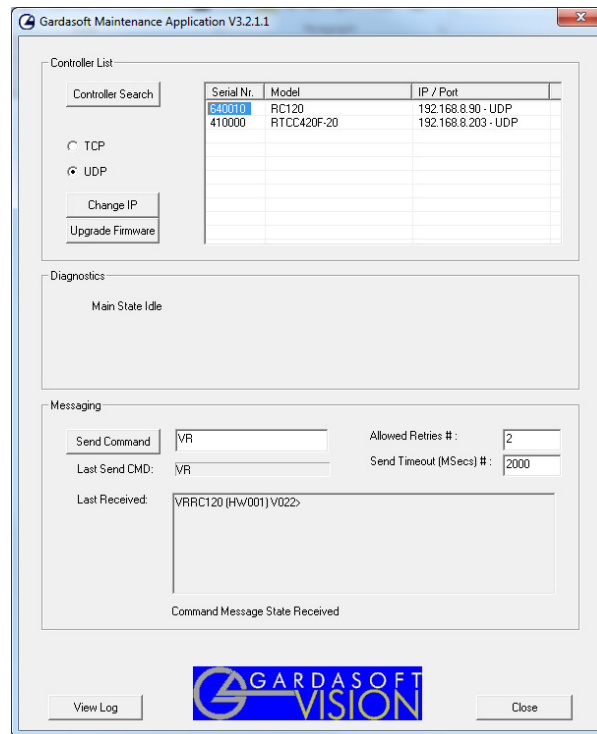

Application note "APP923 Troubleshooting Ethernet problems" is available on the Gardasoft website.

Ethernet set up is not affected by cold-booting the RC120.

9.1 Connection

The Ethernet link uses a 10Base-T connection on an RJ45 connector. The RC120 is usually connected to a network switch (or hub or router) but it is possible to connect it directly into the network port on a PC using a crossover cable.

When connecting direct to a PC, see "APP923 Troubleshooting Ethernet problems" for information on how to set up the IP addresses.

9.2 IP Address

The RC120 needs an IP address to communicate over Ethernet. There are two ways to get an IP address; either programmed into the unit or using DHCP.

For DHCP mode, the RC120 acquires its IP address, subnet mask and gateway address from a DHCP server. Otherwise the RC120 has a fixed IP address, subnet mask and gateway address.

DHCP mode or the IP address can be set and read the GardasoftMaint Program available for download at www.gardasoft.com.

Most networks use a DHCP server. If there is a PC on the network, you may be able to find out whether a PC on the same network uses DHCP as follows:

- Go to Control Panel
- Select Network Connections
- Right click on Local Area Connection. Select Properties
- From the list, select "Internet Protocol Version 4 (TCP/IPv4)", click Properties

If "Obtain an IP address automatically" is set, then DHCP is probably used. However, there may be an alternative fixed IP address on the "Alternative Configuration" tab.

You can find out what IP address is being used by a PC at any time by:

- Go to Control Panel
- Select Network Connections
- Right click on Local Area Connection. Select Status
- Select the Support tab. The IP address is displayed

When using a fixed IP address, you must ensure that you use an IP address that is not being used by any other device on the network. It is usual to keep the first three numbers of the IP address the same as other devices and to change only the last number. For example, if you have a network consisting of a PC (IP address 192.168.1.35) and two RC120s, the RC120s could be allocated addresses 192.168.1.201 and 192.168.1.202.

9.2.1 Automatic Sensing

The RC120 sends a message on three events:

- On power up
- When an IP address is received or renewed by DHCP
- When an enquiry message is received

On the first two events, the message is broadcast. On the third it is a reply to a single IP address.

An enquiry message is a UDP packet from source port 30310, destination port 30311 with the message body "Gardasoft Search" (8-bit ASCII, 13 characters).

The message output by the RC1XX is a UDP packet from source port 30311, destination port 30310. It is formatted as:

```
Gardasoft,RC120,000000,111111111111,22222222
```

(8-bit ASCII, 44 characters), where

000000	the serial number of the unit
111111111111	the MAC address in 6 HEX bytes
22222222	the IP address in 4 HEX bytes

For example for RC120 serial number 12345, IP address 192.168.1.103, MAC address 00.0B.75.01.80.99 the packet is formatted:

```
Gardasoft,RC120,012345,000B75018099,C0A80167
```

10 Webpage Configuration (RC120)

The RC120 has a webserver inside, so that it can be configured from a standard web browser, such as Internet Explorer.

To find the IP address of the RC120, use the “Controller Search” function of GardasoftMaint (see section 9). Then open a web browser window and type the IP address (for example 192.168.8.34) of the RC120 given by GardasoftMaint, into the URL box at the top of the browser. The main page of the RC120 webserver should now be shown.

10.1 Main Page

The main page shows general information about the RC120. Links are provided to the configuration pages.



10.2 General Setup Page

The General Configuration page allows the webpage protection password to be set or cleared and the internal trigger to be set up. Also any Ethernet command from Section 11 can be entered.

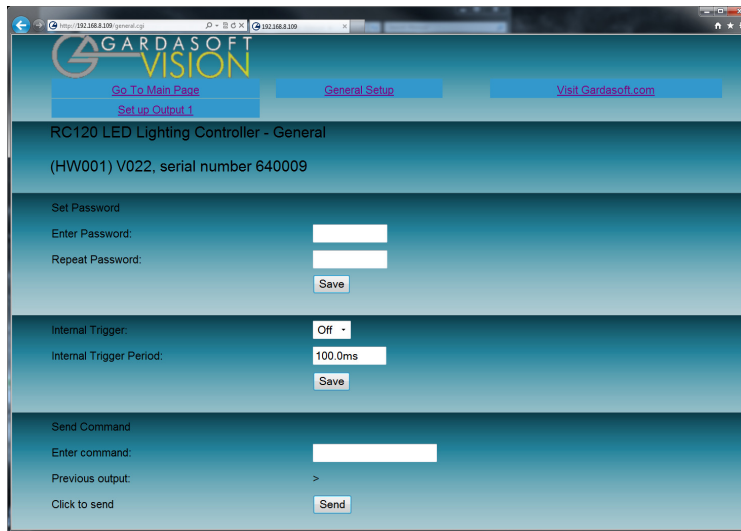

The screenshot shows a web browser window displaying the GARDASOFT VISION interface. The page title is "RC120 LED Lighting Controller - General" with the hardware ID "(HW001) V022, serial number 640009". The interface is divided into three main sections:

- Set Password:** Contains two input fields for "Enter Password:" and "Repeat Password:", followed by a "Save" button.
- Internal Trigger:** Features a dropdown menu for "Internal Trigger:" set to "Off", an input field for "Internal Trigger Period:" set to "100.0ms", and a "Save" button.
- Send Command:** Includes an input field for "Enter command:", a label "Previous output:" with a ">" symbol, and a "Send" button.

10.3 Configuration Page

The configuration page allows all the output parameters to be set up. Pressing the Submit button updates the RC120 configuration and save the changes to non-volatile memory.

The current rating for the light can be changed. Use this with care.

Some measured voltages and the actual output current are displayed on this page.



The screenshot displays the GARDASOFT VISION web interface for configuring an RC120 LED Lighting Controller. The browser address bar shows the URL <http://192.168.8.109>. The page header includes the GARDASOFT VISION logo and navigation links: [Go To Main Page](#), [General Setup](#), and [Visit Gardasoft.com](#). Below the header, there is a link for [Set up Output 1](#).

RC120 LED Lighting Controller - Channel 1 Configuration

(HW001) V022, serial number 640009

Mode:

Trigger:

Brightness (%):

Brightness 2 (Selected Mode) (%):

Pulse Delay:

Pulse Width:

Retrigger Delay:

Flags: Error Detect Pos Trigger Autosense Enabled

Click to update

Status: Connected

Dissipation: 1.0W

Measured Current: 0.497A

Supply Voltage: 24.7V

SafePower(TM) Voltage: 12.3V

Lighting Voltage: 10.3V

Expected Voltage: 10.3V

Voltage Drop: 2.0V to 2.2V

Duty Cycle: 100.0%

Trigger Count: 6213, TRIG1 = 0

Click to Refresh

Rating (For example 12V or 0.3A):

Click to change

11 Command Configuration (RC120)

The RC120 can be configured via the Ethernet connection using UDP or TCP/IP. A Configuration Program with source code is available for download from www.gardasoft.com.

11.1 Ethernet Communication (RC120)

Commands sent from a PC in UDP and TCP packets should be sent to destination port 30313. Replies will be sent back to the source port (so in the reply the source and destination ports will be swapped).

A TCP/IP connection timeouts and closes if it is idle for more than 10 seconds. The host must send regular commands or keepalive packets to keep the link open.

A carriage return (ASCII 13) character should be sent to terminate the command line, in case multiple TCP packets get joined together.

11.2 Command Structure

Communication consists of commands sent by the host (controlling PC). The command and any reply output generated by the command is returned in reply UDP or TCP/IP packets followed by <LF> <CR>. The last character sent is a ">" prompt ("greater than" symbol). Once this is received, the host knows that the command has been completed.

For example when sending the VR command the reply might be:

```
VRRRC120 (HW001) V002<LF><CR>>
```

Where

The red text is the command reflected back

The green text is the reply data

The blue text is control codes ASCII 10, ASCII 13

The black text is the prompt ">"

If there is an error (see error codes below) then a typical reply is:

```
VTErr 2<LF><CR>>
```

It is recommended that the host waits for the ">" symbol before sending the next command. UDP communications are not guaranteed to arrive, so the host software must be able to cope with lost messages.

Using the GT command, a host can request that a message is sent to it whenever an error occurs.

Several commands can be put into one command line by separating them by a semi-colon (;). The RC120 send any replies to the commands followed by a ">" character to show that the command line has completed.

All commands comprise a code of two letters followed by any optional parameters. All spaces in the commands are ignored.

Numeric parameters are separated by a comma (","). For a parameter which is a time period the default units are milliseconds. "s", "ms" or "us" can be added to the end of the number to indicate seconds, milliseconds or microseconds. For currents, "A" or "mA" can be added to indicate "amps" or "milliamps". **The default is amps.**

Note that parameters are in "USA/UK" format so that a half is written "0.5" not "0,5"

For example:

Parameter	Meaning
0.1	0.1 milliseconds
200us	200 microseconds
0.1s	0.1 seconds
100ma	100mA
2.45A	2.45A
2.3	2300mA or 2.3A

The command codes and their meaning are described below. The upper case commands are shown, followed by lower case letters denoting the numeric argument.

If a command is invalid in any way an error message is returned before the <LF> <CR> ">" reply.

Error number	Reason
Err 1	A parameter value is invalid
Err 2	Command not recognised
Err 3	Numeric value is wrong format
Err 4	Wrong number of parameters
Err 5	(This is only a warning) The command is accepted but a timing parameter was out of range and has been adjusted to a valid value.

Any changes made using Ethernet commands are not saved permanently until the AW command has been issued.

11.2.1 General Commands

Report the version of firmware running in the RC120

This command returns the firmware version. For example:

VR
 RC120 (HW001) V001

Set the rating of a light

This command sets the current or voltage rating for a light. If a current rating is being set, then the voltage rating value should be 0.

VL1,v,c

Where:

v = voltage rating (0 or 12 to 24)
 c = current rating (0 or 10mA to 2A)

Set continuous mode

The output is set to continuous mode at a percentage of full brightness.

RS1,s

Where:

s = setting in percent (s = 0 to 100)

Set pulse mode

The output can be set up to pulse on a trigger input. The delay from trigger to the start of the pulse, the length of the pulse and the brightness are configurable.

An error is generated if the brightness setting requires a current greater than the maximum current output or if the combination of pulse width and setting is not allowed.

If the retrigger time is omitted, then the minimum allowed retrigger time is set.

RT1,p,d,s

RT1,p,d,s,r

Where:

p = pulse width in milliseconds (0.1 to 999)
 d = delay from trigger to pulse in milliseconds (0 to 999)
 s = setting in percent (s = 0 to 999)
 r = retrigger delay. This parameter is optional.

Set switched mode

The output is set to switched mode at a percentage of full brightness.

RW1,s

Where:

s = setting in percent (s = 0 to 100)

Set the Trigger Input

This command sets which input is used for pulse and switch output modes.

RP1,p

Where:

p = trigger input (1 or 2)

Set the Option Flags**RE1,m**

Where:

m = flags:

bit 0 Not used

bit 1 = 0 E flag set (error detection enabled)

1 E flag cleared (error detection disabled)

bit 2 = 0 P flag set (positive triggers)

1 P flag cleared (negative triggers)

bit 3 = 0 S flag set (SafeSense enabled)

1 S flag cleared (SafeSense disabled)

Set Internal Trigger

Enable or disable the internal trigger. When enabled, all outputs are triggered simultaneously using an internal trigger signal. This setting can be saved to non-volatile memory using the AW command.

TT0 Disable internal trigger

TT1 Enable internal trigger (uses previously set period)

TT1,p Enable internal trigger and set the period

Where:

p = period of the triggers in milliseconds

For example:

TT1,200 Set the internal trigger to 200ms (5Hz)

TT1,500US Set the internal trigger to 500us (2KHz)

Save the settings to memory**AW**

Once the settings are saved to memory they are then retained when the unit is switched off. If this is not done, changes to the settings are volatile, and if the unit is switched off they revert to those in force when the last AW command was issued.

Clear Configuration**CL**

Clears the configuration and lighting ratings and sets the output to 50% continuous operation. The results of the VL, RS, RW, RU, RT, RE, RP, TT, AW commands are all cleared.

Show Configuration

ST

This command shows the configuration of the controller. A typical output for a RC1XX controller is:

CH1,MD0,S50.0,0.0,DL1.000ms,PU1.000ms,RT0.0us,IP1,FL0,CS0.000A,RA0.000A

Where:

CH Channel number (RC1xx units have 1 channel)

MD Mode: 0 = continuous, 1 = pulse, 2 = switched, 3 = select

S Brightness percentage settings:

1st setting used in all modes

2nd setting only used for select mode

DL Pulse delay

PU Pulse width

RT Retrigger delay

IP Input Trigger (set using the RP command)

FL Flags (set using the RE command)

CS Current rating of the light (after SafeSense™ has successfully completed sensing the light)

RA Configured voltage or current rating of the light (set using VL command)

When using Ethernet, use the following forms of the ST command as the command above will generate more data than can be sent in a reply packet.

ST0

Reports the general settings. Typical output is:

TM 1, TP 20.00ms

ST

Reports output settings.

Simulate an Input Trigger

TR1

Simulates a trigger pulse. If the unit is in pulse mode it pulses the output once and shows "PUL" on the display.

Enable Ethernet Messages

GTm

m = 0 to disable Ethernet messages

= 1 to enable Ethernet messages

When Ethernet messages are enabled, any error reports are sent to the most recent UDP or TCP address from which a command has been received.

Messages are of the form:

Evtc,e

Where c 1 for events concerning the lighting output, else 0
v event value, see appendix E

Clear any Errors**GR**

If Ethernet messages are not enabled, the last event or error number can be read by this command. Any error displayed on the unit is cleared, so if there was a lighting error, the RC1XX resumes auto-sensing on that channel.

The reply is in the same form as the GT command above. If there are no outstanding events or errors, then only the prompt ">" is returned.

Set/Clear the Webpage Password**EY****EY asc1, asc2, asc3, asc4, asc5, asc6**

This command sets the password required to access the webpages. If EY is entered on its own then the password is cleared. There are six optional parameters, which are decimal ASCII values for a password from one to six letters. A value of 65 is 'A', 66 is 'B', etc to 90 is 'Z'.

Disable Keypad**KBd,c**

- d = 0 Enable keypad
- d = 1 Disable keypad, but allow unlock code
- d = 2 Disable keypad, disable unlock code
- c Unlock code

In some applications it may be necessary to lock the keypad so that un-authorized operators cannot change the settings.

A unlock code can be set. This can be used as a low-security way of allowing trusted users to unlock the keypad. Ethernet commands and the web pages still work. The setting of this command is restored after a power cycle.

11.2.2 Command Summary

Command	Example	Effect
AW	AW	Save changes
CL	CL	Clear configuration
GT	GT1	Enable Ethernet messages
GR	GR	Clear any error condition.
EY	EY65,66	Set webpage password to "AB"
VR	VR	Read the firmware version
VL	VL1,0,0.5	Set the light rating to 0.5A
RS	RS1,65	Set unit to 65% brightness continuous
RW	RW1,50	Set unit to 50%, switch mode
RU	RU1,75,25	Set unit to selected mode at 75% and 25%
RT	RC1,3,4,50	Set unit to 3ms pulses, delayed by 4ms, at 50% brightness
RE	RE1,6	Set unit to ignore lighting errors and make its trigger input active low.
TT	TT1,1ms	Set internal triggers every 1ms
KB	KB1,23	Disable the buttons on the front panel. Set the unlock code to 23.
TR	TR1	Generate one Trigger pulse
ST	ST	Show Configuration Status

A. Specification

	RC100	RC120
User interface	Pushbutton	Ethernet and Pushbutton
Output channel	One constant current output with SafeSense™	
Output current	Up to 1.0A continuous or 1.0A pulsed	Up to 1.2A continuous or 2.0A pulsed
Output power	Max 25W	
Trigger input	Smart input compatible with 3V-24V, TTL, NPN, and PNP. Input impedance (nom): 50Kohm	
Pulse timing	From 100µs to 100ms in steps of 100µs	
Delay from trigger to pulse	From 2µs to 100ms in steps of 100µs	
Timing repeatability (Delay)	+/-5µs (Delay + Pulse up to 60ms) Otherwise +/-50µs	
Timing repeatability (Pulse width)	+/-0.1µs (Delay + Pulse up to 1ms) +/-5µs (Delay + Pulse from >1ms to 60ms) Otherwise +/-50µs	
Switch mode latency	Maximum 100us	
Trigger rate	Maximum 100Hz	
Output voltage	0V to 32V	
Supply voltage	Regulated 24VDC+/-10% A SELV power supply is required.	
Dimensions	101mm long by 35mm wide by 120mm high (excluding DIN fixing)	
Weight	175g	
Mounting	DIN rail mount as standard	
Operating temperature:	5 to 50°C	
Humidity:	Up to 95% non-condensing	

B. Restrictions

The following timings and restrictions are applied when commands are entered. Exceeding these values will cause an error to be returned.

The keypad interface prevents invalid values being entered.

B.1 Continuous Mode

The maximum continuous output current is 1A (RC100), 1.2A (RC120).

B.2 Switched Mode

The maximum delay from a trigger input changing to the output current being turned on or off is 100us. The maximum output current limit is the same as Pulse mode.

B.3 Pulse Mode

The maximum pulsed output current is 1.2A (RC100), 2A (RC120).

For high current pulses the following limits apply:

When a delay of 0us is set, the actual delay will be about 4us.

For pulse widths of 100us the output voltage and current cannot be measured. Because of this, fault detection is disabled and the following restrictions apply:

- For pulse currents greater than 0.5A, the duty cycle is restricted to 1%
- For pulse currents less than or equal to 0.5A, the duty cycle restricted to 10%

C. Error Codes

Error number	Reason
Err 1	A parameter value is invalid
Err 2	Command not recognised
Err 3	Numeric value is wrong format
Err 4	Wrong number of parameters
Err 5	This is a warning, not an error. One of the parameters is out of range. The value of the parameter has been adjusted. For example, sending an RT command with a delay of 0 gets a reply of "Err 5". The command is accepted but the delay is set to the minimum allowed value.
Err 19	A light has been connected to a channel but no rating has been set.
Err 8, 12	EEPROM corrupt. The configuration has been cleared.
Err 9, 20	Couldn't save settings to EEPROM.
Err 21, Err 22, Err 23	Sensing error. See section 6.6.
Err 27	Can't read Ethernet settings from EEPROM, so these may be incorrect.
PO, Err 34, Err 47	Internal power dissipation is too high. Output turned off.
OP, Err 35	Output current to lighting is too low.
OP, Err 43	The requested output current requires too high a voltage.
SH, Err 36	The output is short circuit.
SH, Err 42	The output current is too high.
HI, Err 37	The voltage required for the lighting has increased too much. Check for ageing of the lighting or a failed LED.
LO, Err 38	The voltage required for the lighting has decreased too much. Check for ageing of the lighting or a failed LED.
Err 39	Internal protection has prevented SafePower voltage going too high.
Err 46	The channel power output is greater than the maximum allowed 30W.

Any other errors are internal errors.

D. Fatal Error Codes

Error number	Reason
FAt, Err 44	The RC1XX is too hot. The RC1XX has a thermal cutout which operates around 65°C to 70°C, depending on conditions.
FAC, Err 40, Err 41, Err 45	Unit is outputting more current than expected.
FAS, Err 47	Internal protection has activated to prevent too much heat in the output driver.

E. Event Codes

Event messages are sent by Ethernet when a light is connected or an error occurs. The format of these is

Evt<channel>,<event code>;

These event messages are only sent after the GT1 command has been sent.

Event number	Reason
1 to 127	An error has occurred. The error code is given by the event number.
128	A light has been connected and is working.
129	A light has been connected but doesn't have a current or voltage rating.
130	Over temperature error occurred (FAt)
131	Over current error occurred (FAC)
132	An error has occurred while autosensing the rating of a light.
138	SafePower trainup has completed.
139	SafePower trainup has failed or been cancelled.
140	In switch output mode, the light has been turned off because the duty cycle is too high.

Gardasoft Traffic Strobe Lights

The products available at the time of writing include the following. Other products are also available. See www.gardasoft.com for details of the current range.

VTR1 Range

- Up to 300W per steradian output power
- Infra-red 740nm, 850nm, 940nm and White options
- Ethernet and RS232 options
- Trigger input and trigger output options
- 12 degree and 30 degree beam angle options

VTR2 Range

- Up to 3000W per steradian output power
- Infra-red 740nm, 850nm, 940nm and White options
- Ethernet, RS232 and RS422 options
- Trigger input and trigger output options
- 12 degree and 30 degree beam angle options

VTR4 Range

- Up to 6000W per steradian output power
- Infra-red 850nm and White options (others on request)
- Ethernet and RS232 options
- Trigger input and trigger output options
- 12, 14 degree and 28 degree beam angle options

VTR6 Range

- Up to 9000W per steradian output power
- Infra-red 850nm and White options (others on request)
- Ethernet and RS232 options
- Trigger input and trigger output options
- 12, 14 degree and 28 degree beam angle options

Gardasoft LED Lighting Controllers

The products available at the time of writing include the following. Other products are also available. See www.gardasoft.com for details of the current range.

RT/RC Range

- 1, 2, 4 or 8 output channels
- 2A and 20A maximum current version available
- 1, 2, 4 or 8 trigger inputs
- SafePower™ and SafeSense™
- Front panel, RS232 or Ethernet configuration
- Fast pulsing option

RC100	Lighting controller: 1 channel up to 1A pulsing, front panel
RC120	Lighting controller: 1 channel up to 2A pulsing, front panel and Ethernet
RT200-20	Lighting controller: 2 channels up to 20A pulsing, front panel
RT220-20	Lighting controller: 2 channels up to 20A pulsing, Ethernet
RT260-20	Lighting controller: 2 channels up to 20A pulsing, RS232
RT200F-20	Lighting controller: 2 channels up to 20A fast pulsing, front panel
RT220F-20	Lighting controller: 2 channels up to 20A fast pulsing, Ethernet
RT260F-20	Lighting controller: 2 channels up to 20A fast pulsing, RS232
RT420-20	Lighting controller: 4 channels up to 20A pulsing, Ethernet
RT420F-20	Lighting controller: 4 channels up to 20A fast pulsing, Ethernet
RT820F-20	Lighting controller: 8 channels up to 20A fast pulsing, Ethernet
RT860F-20	Lighting controller: 8 channels up to 20A fast pulsing, RS232

PP Range

- 2, 4 or 8 output channels up to 20A each
- 2, 4 or 8 trigger inputs
- SafeSense™ option
- Front panel, RS232 or Ethernet configuration
- Fast pulsing option

Machine Vision Timing Controller

CC320 Controller

- 8 digital inputs
- 8 digital outputs
- 1 or 2 wire Encoder input
- Very flexible operation
- Ethernet control
- Front panel configuration