

CamPerform CP80-25-M/C-72 CoaxPress Camera



User Manual

Ref. 1889-SU-01-D

Contents

Revision	3
General	4
Declaration of conformity	4
RoHS compliance	4
Scope of delivery	5
Optronis customer service	5
Remark, Attention	6
Precautions	6
Camera Power	6
Environmental Conditions	6
General Precautions	7
Camera	8
Electrical Interface	9
Auxiliary (Aux.) connector pinout	9
Camera Power	11
Indicator Lamp (LED)	12
CoaxPress Data Channels	12
Lens mount and handling	13
Nikon F-Mount adapter	13
C-Mount adapter	15
Important features	15
Frame format	15
Minimum Frame rate (@ internal synchronisation)	15
Maximum Frame rate (@ internal synchronisation)	15
Max. Frame Rate Examples:	17
Calculation of Exposure Time	17
Frame Rate (@ external synchronisation)	18
Technical Data	19
General	19
Spectral Response / Transmittance	20
Mechanical Dimensions	21
F-Mount Lens (/CM)	21
Synchronisation Input schematics	23
Synchronisation Output schematics	23
Internal Synchronisation Timing	24
Synchronisation Output	24
External Synchronisation Timing	25
Synchronisation Input “level detection”	25
Synchronisation Output “level detection”	25
Focal Length Calculation	26
Full Sensor Resolution	26
Reduced Sensor Resolution	26
Distance Washer	27
Camera firmware update	29
Camera mapping	31

Revision

Cameramodel	Date	Description
CP80-25-M/C-72 SNr. 1889-ST-xxx	30.04.2013	Firmware 6.01
CP80-25-M/C-72 SNr. 1889-ST-xxx	23.05.2013	Firmware 6.02 Gain = 1,39; Offset < 10
CP80-25-M/C-72 SNr. 1889-ST-xxx	11.11.2013	Firmware 8.0 - Add offset and gain calibration menu in xml file - Add 'Rolling shutter' mode in the xml file -Add of 'Granularity' mode which allows to set exposure time through register when using external synchronisation of trigger over CoaxPress
CP80-25-M/C-72 SNr. 1889-ST-xxx	28.11.2013	Firmware 8.1 - Add flash configuration in xml file (see FlashSaveWithAutoStart, FlashSaveWithoutAutoStart, DisableFlashLoad) - Add Pixel Format saving in the flash configuration

General

Declaration of conformity

Manufacturer: Optronis GmbH
Address: Ludwigstr. 2, 77694 Kehl, Germany

We certify and declare under our sole responsibility that the following apparatus

Product: CP80-25-M-72
CP80-25-C-72

conform with the essential requirements of the EMC Directive 2004/108/EC, based on the following specifications applied:

Specifications: EN 61000-6-3 Emission
EN 61000-6-1 Immunity

Kehl, 23.05.2013

Optronis GmbH
Dr. Patrick Summ
Managing Director

RoHS compliance



CamPerform CP80-25-M/C-72 cameras are Pb free manufactured.

Scope of delivery

CP80-25-M/C-72 CoaxPress camera

Options: /C: Color sensor (Bayer Pattern)
 (IR Cutoff Filter, Specification: 1830-SS-10)
 /M: Monochrome sensor

Lens mount: /CM: CMount
 /FM: FMount
 /FMG: FMount for Nikon G-Lens series

CoaxPress: up to 6,25Gbit/channel, 4 channels

Synchronisation Adapter cable

Programming cable (USB2) for firmware update

User Manual (CD-ROM)

Optronis customer service

Optronis GmbH
Ludwigstr 2
77694 Kehl
Germany
Tel: +49 (0) 7851 9126 0
Fax: +49 (0) 7851 9126 10
E-mail: info@optronis.com

For any questions or problems, please do not hesitate to ask our customer service. Please prepare the following information:

- Camera type: CP80-25-M-72 or CP80-25-C-72
- Serial-Number: see label at the bottom side of the camera
- Frame Grabber
- Operating System (Windows XP/Vista/32bit/64bit ...)
- Short description of the problem

Remark, Attention

This user manual is compliant with the firmware version v.6.02 of the camera.
The following signs are used in the user manual



Remarks and additional information



Attention

Precautions

Camera Power

Please use Power over CoaxPress or as an option the CP80-25-M/C-72 camera power supply (not included in shipment).

Environmental Conditions

Temperature range during operation: < + 45°C (housing temperature)
> 0°C (ambient temperature)

Humidity during operation < 80% non-condensed



At high ambient or housing temperatures the camera lifetime will be reduced. Avoid camera operation beyond temperature limits. Please ensure, that the housing temperature will be kept as low as possible by additional heatsinks.

General Precautions

Read the user manual carefully before using the camera.

Do not orientate the optical input of the camera to direct sunlight.

Keep the camera free protected from dirt, dust, grease and water.

Make sure that all the connecting cables are in good condition. Defective cables have to be replaced.

Always unplug the camera before cleaning it. Do not use cleaning liquids or sprays. Instead, use a dry and soft duster.



There are no serviceable parts inside the camera. Do not open the housing of the camera.

Warranty becomes void if the camera housing is opened.

Camera



- | | |
|--------------------------------------|--|
| 1: Camera housing | 2: Mounting holes 2x M4x6mm 1x ¼" x6mm |
| 3: Lens mount (Nikon-F) | 4: Nikon lens |
| 5: electrical interface (right side) | 6: Mounting holes 4x M4x6mm |

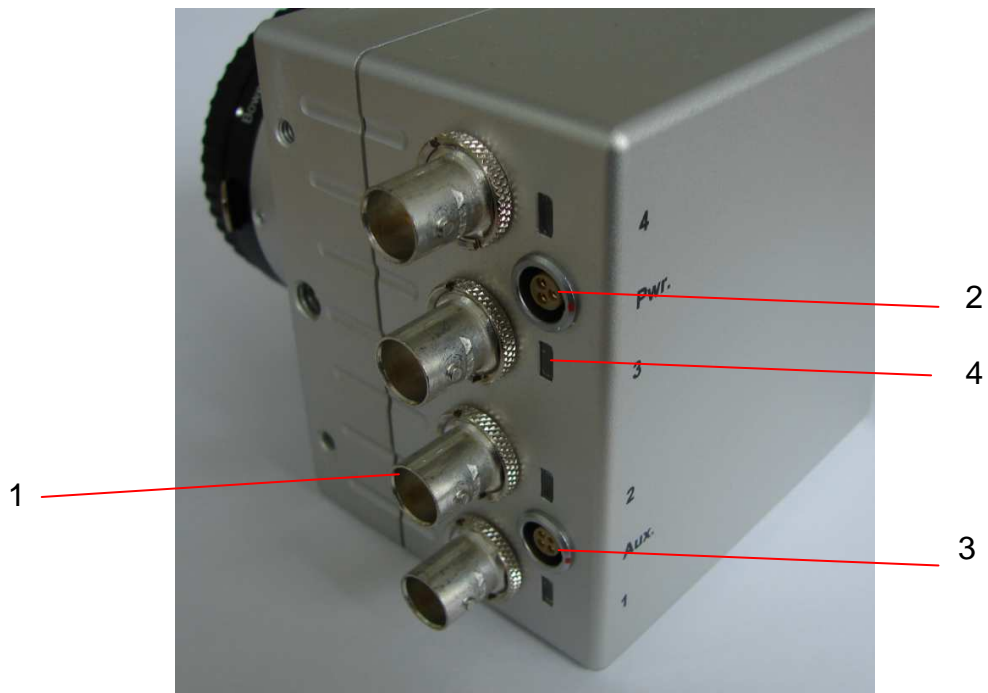

1: CoaxPress Channel
3: Auxiliary Connector

2: Power Connector
4: Indicator Lamp (LED)

Electrical Interface

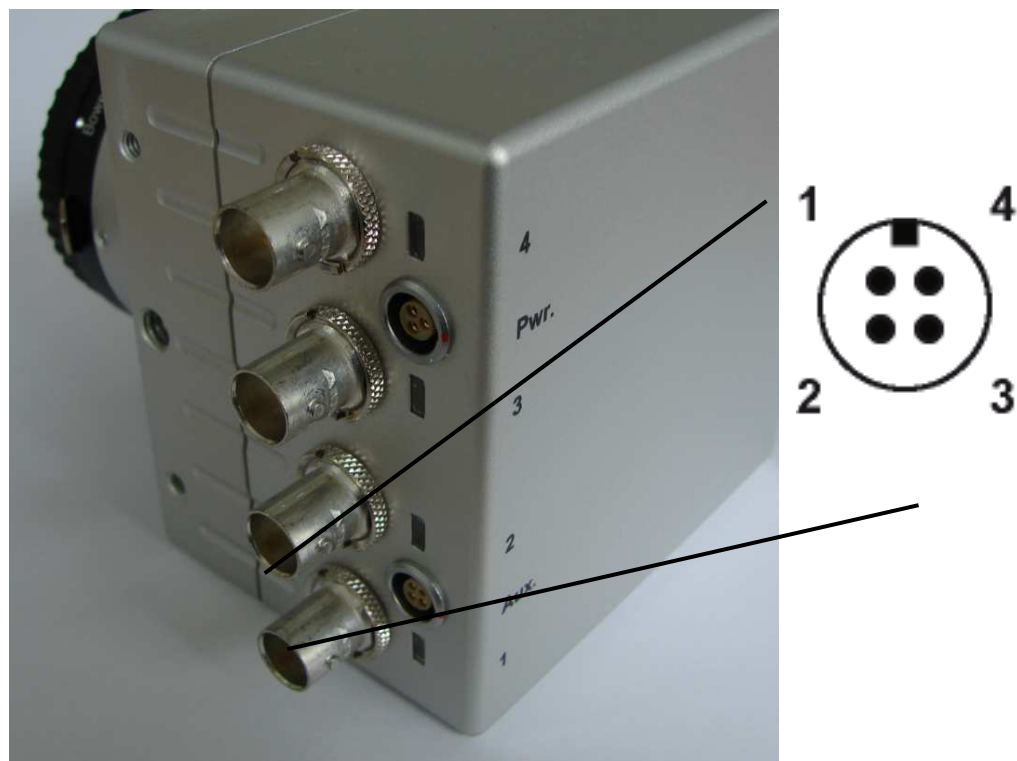

Auxiliary (Aux.) connector pinout

Auxiliary (Aux.) connector pinout		
Pin Nr.	Description	
1	Sync. In	External Synchronisation Input TTL level: <0,8Volt (low) > 2 Volt (high)
2	reserved	-

3	GND	Sync. Ground
4	Sync. Out	External Synchronisation Output (TTL level @ high impedance, 0 to 2 Volt @ 50 Ohms)



To operate SyncIn correctly, a SyncIn driver circuit has to be used.

Minimum Sink Current (TTL Low Level) of the SyncIn Driver has to be 5mA. At 5mA Sink Current the input level at the SyncIn camera input drops below 0,8Volts.

Source Current (TTL High Level).of the SyncIn Driver is negligible (0mA)

Easiest driver circuit is a Transistor working in open collector configuration.



SyncIn input voltage limit ranges from – 5 Volts to + 30 Volts. Voltages applied beyond these limits may damage the SyncIn Input.



SyncOut has a built in 50 Ohm driver.

At 50 Ohm termination, the driver voltage is in between 0 (low level) to ~2 Volts (high level). At high impedance termination, the driver voltage is in between 0 (low level) to ~4 Volts (high level).



SyncOut voltage limit ranges from 0 Volt to + 5 Volts. Voltages applied beyond these limits may damage the SyncOut Output.



The Auxiliary connector may also be used to update the firmware of the camera. Please use the USB2 programming adapter cable.

Camera Power

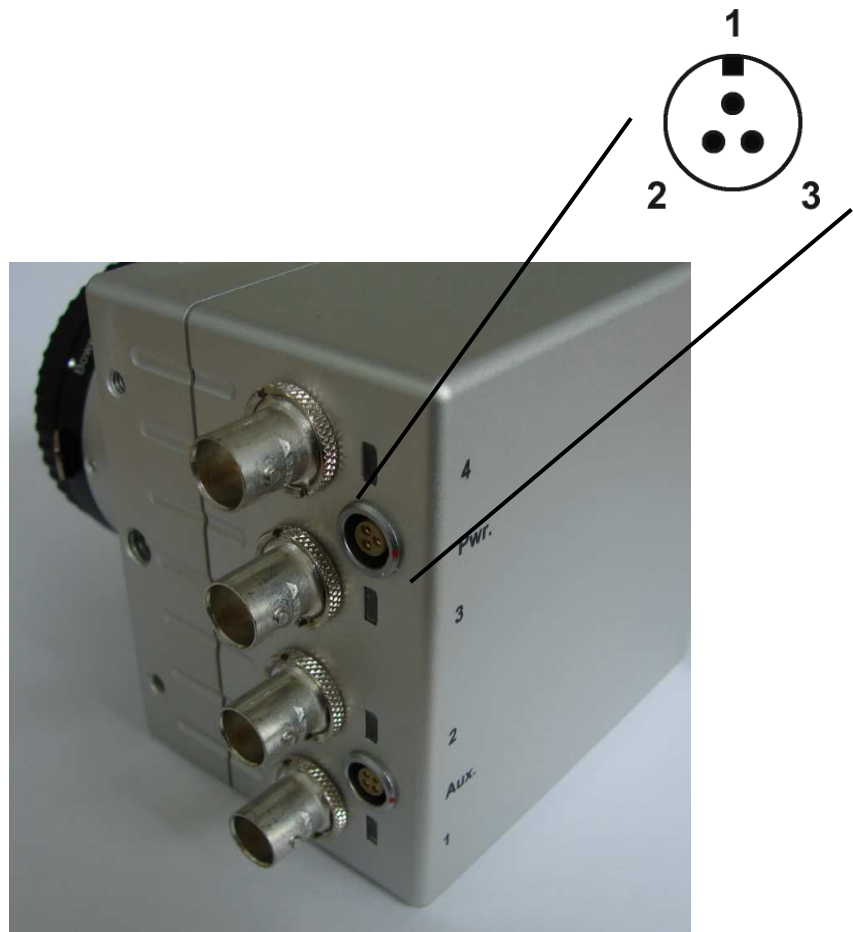

Figure: CP80-25-M/C-72 side view

Camera (Pwr.) connector type: Lemo EGG.0B.303CLL

Cable Connector: Lemo FGG0B303.CLAD56Z

Power (Pwr.) connector pinout		
Pin Nr.	Description	
1	VCC	DC Power +24Volt +/-5% (Ripple < 200mV) Inrush Current ~0,6A
2	GND	Power Ground
3	reserved	-



Alternatively Power over CoaxPress (PoCXP) can be used.

Indicator Lamp (LED)

State	Indication
No power	Off
System booting	Solid orange
Powered, but nothing connected (only for power over power connector)	Slow pulse red
Link detection in progress, PoCXP active	Fast flash green
Linkt detection in progress, PoCXP not in use	Fast flash orange
Camera / Grabber incompatible, PoCXP active	Slow flash alternate red / green
Camera / Grabber incompatible, PoCXP not in use	Slow flash alternate red / orange
Camera connected, but no data being transferred	Slow pulse green
Camera connected, waiting for event (e.g. trigger, exposure pulse)	Slow pulse orange
Camera connected, transferring frames	Solid green
Error during data transfer	500ms red pulse
System error	Fast flash red



Camera is in calibration mode, when all LEDs are flashing slowly. Calibration mode is directly after startup and can last about 10 seconds.

CoaxPress Data Channels

To operate the camera, all 4 CoaxPress Channels (Labeling: BNC 4x) have to be used. Channel 1 is Master link. Channel 2, Channel 3 and Channel 4 are Extension links. Channel 1 uses Power over CoaxPress (PoCXP). Speeds of the Downlink are 6,25Gbit/s, 5,00Gbit/s or 3,125Gbit/s depending on the speed transfer capabilities of the frame grabber.

Lens mount and handling

Nikon F-Mount adapter

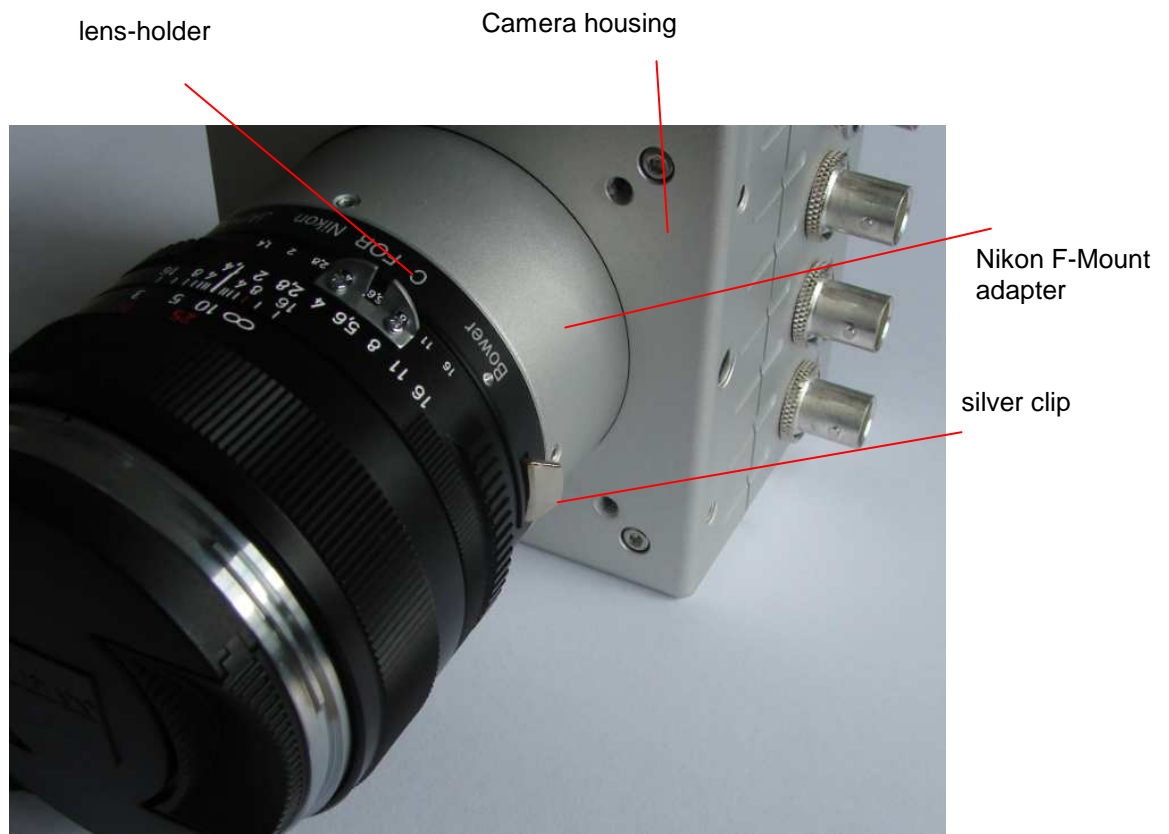
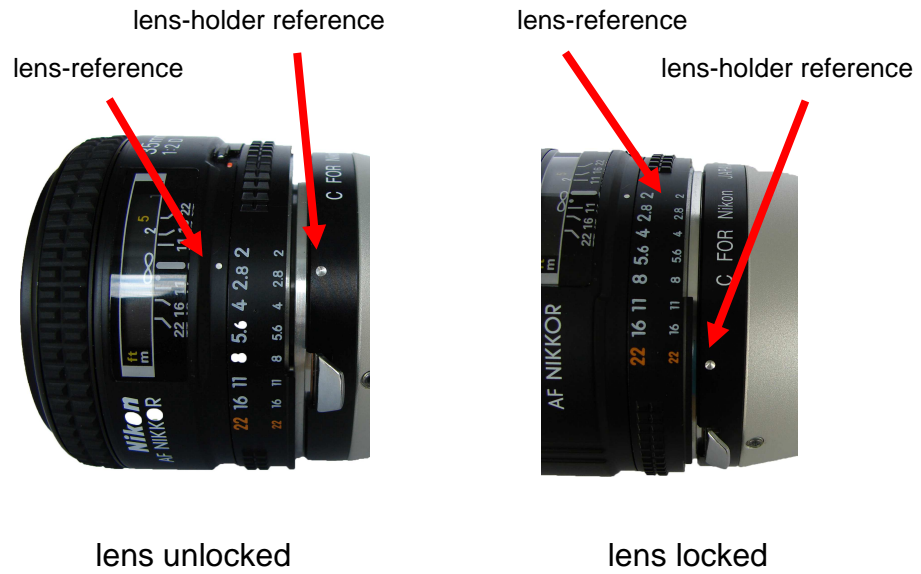

Figure: Camera with Nikon F-Mount adapter

To mount the lens, it has to be positioned on the lens-holder in a way, that the back surface of the lens is completely attached to the surface of the lens-holder.

The lens-reference has to be positioned in face to the lens-holder reference as shown in the figure below. Then, the lens has to be turned anti-clockwise until the silver clip on the lens-holder locks.



To unmount the lens, pull back first the silver clip in order to unlock the lens as shown below. Then (the silver clip has still to be pulled back) turn the lens clockwise until the lens is unmounted completely.



C-Mount adapter

To mount the C-Mount lens, unscrew the protective cover anti-clockwise and mount the C-Mount lens into the lens holder.

To unmount the lens, unscrew the C-Mount lens anti-clockwise.

Important features

The CamPerform CP80-25-M/C-72 CoaxPress cameras are a high resolution, high frame rate CMOS area scan camera that are designed for industrial use. The image sensor and the camera offer exceptional high performance:

- excellent image quality
- excellent sensitivity
- low noise
- monochrome and color
- internal and external synchronisation
- Region of Interest (ROI)

Frame format

The Frame format (frame resolution) of the camera is 5120 active Pixels in horizontal (x) direction and 5120 active Pixels in vertical (y) direction at full resolution. The frame format can be reduced by factor of 256 Pixel in horizontal direction and factor of 4 Pixel in vertical direction.

The frame format can be reduced by selecting a region of interest (ROI).

Minimum Frame rate (@ internal synchronisation)

Minimum frame rate is limited to 10 fps in free run mode.

Maximum Frame rate (@ internal synchronisation)

The minimum frame interval (maximum frame rate) that can be reached by the camera internal synchronisation mode depends on the CoaxPress Speed (Bit Rate).

Compliance labeling	Bit Rate (Gbps)	Maximum frame rate	
CXP6	6,250	72	

Figure: Supported high speed link bit rates

Frame Rate (@ external synchronisation)

For external synchronisation please apply a TTL signal to the Sync In and Sync Out BNC adapter of the adapter cable (scope of delivery). External synchronisation may be operated in level detection mode. Please see the external synchronisation timing for more information about resulting frame rates and exposure times.

Alternatively SyncIn can be applied directly between Pin 1 and Pin 3 on the camera power (Pwr.) connector, Sync Out between Pin 4 and Pin 3. The synchronisation output can be used to synchronise other devices as e.g. additional cameras or external light flashes.



The External synchronisation frame rate range can reach any value between 10 fps and maximum Frame Rate @ internal synchronisation.

Technical Data

General

Power Source	+ 24 Volt +/- 5% DC < 200mV ripple Alternatively PoCXP
Power	approx. 12 Watt
Pixel Number	5120x5120
Pixel size	4,5 µm x 4,5 µm
Active area	23,04 mm x 23,04 mm
Sensor responsivity	3,3 Volt/lux.s
Sensor S/N ratio	53 dB (Linear)
Shutter	Global, efficiency ~99,9%
Minimum Ambient Temperature	0 °C
Maximum Housing Temperature	+ 45 °C
Humidity	< 80% relative, non-condensed
Interface	CoaxPress BNC 4x CXP6
Uplink	Over CoaxPress
Video interface	CoaxPress
Size	85 mm x 85 mm x 99,5 mm (F-Mount)
Weight	approx. 600g without lens

Spectral Response / Transmittance

Spectral response (Monochrome / Color Sensor)

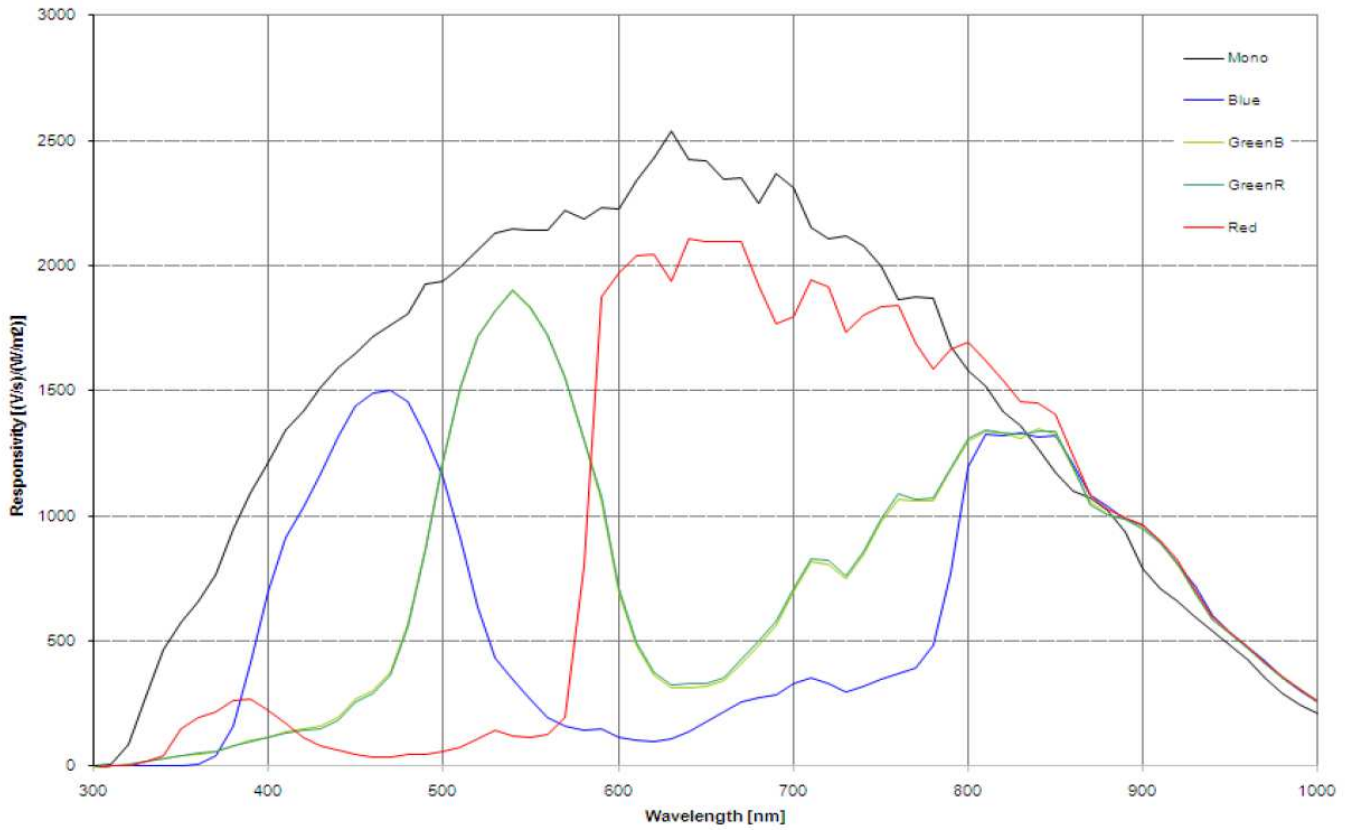

Mechanical Dimensions

F-Mount Lens (/CM)

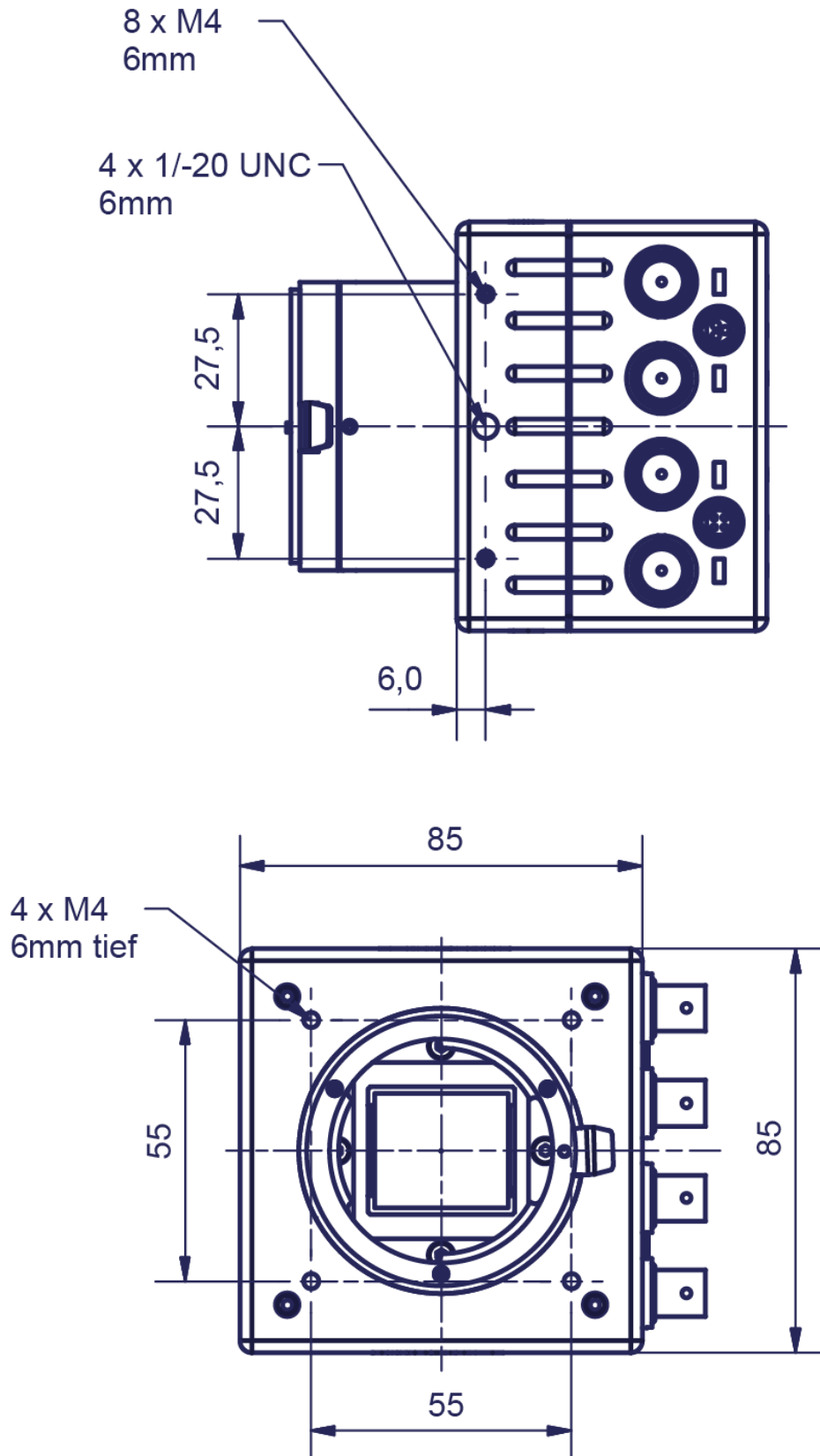

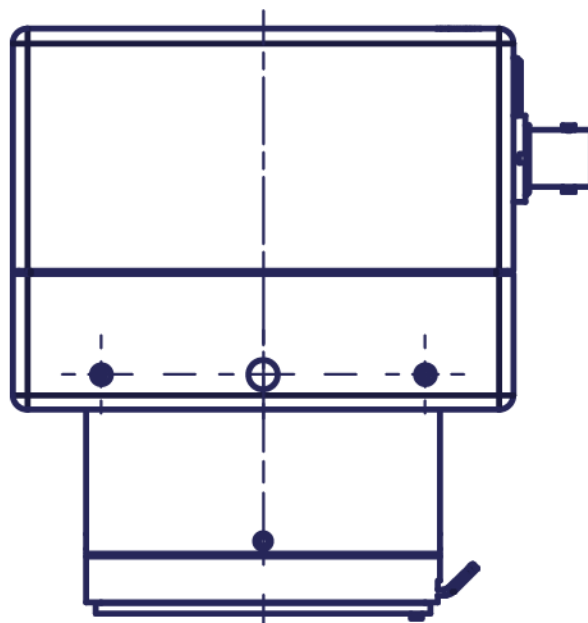
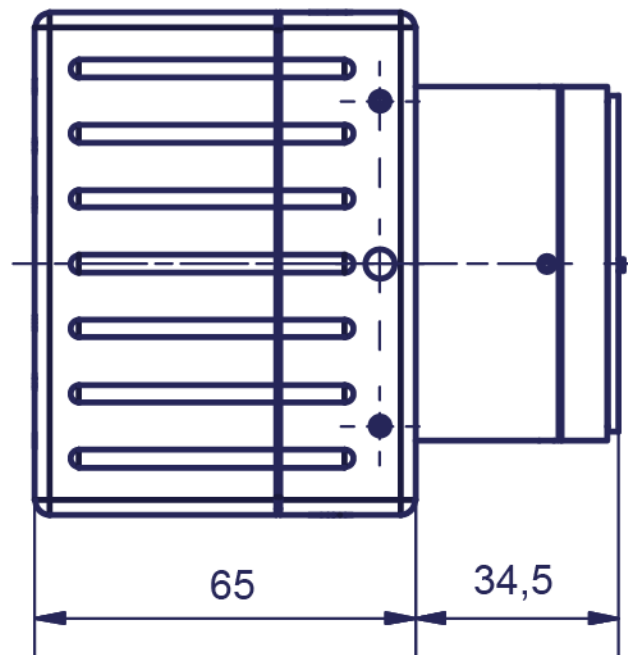

Figure : Side View (all dimensions in mm)

Screw threads in socket:

M4 min. 6 mm depth

1 x ¼ `` min. 6 mm depth (in the middle)

Synchronisation Input schematics

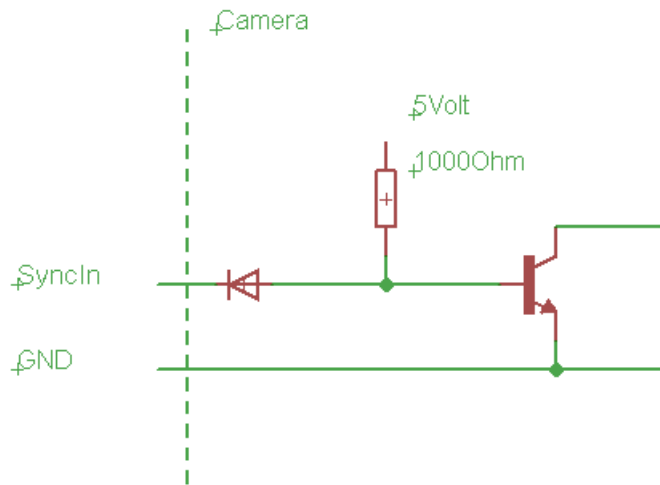

Figure: SyncIn Schematics (for illustration only)

Synchronisation Output schematics

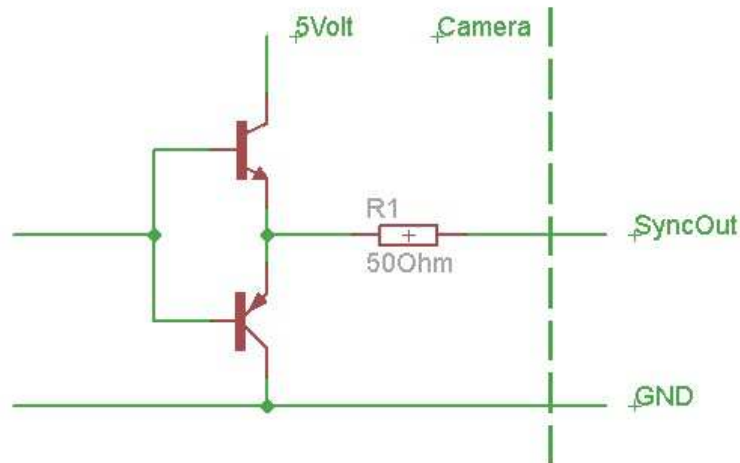
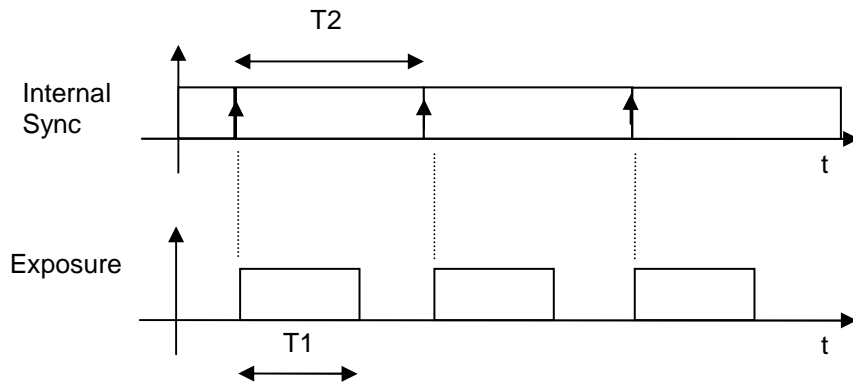

Figure: SyncOut Schematics (for illustration only)

Internal Synchronisation Timing



T1: Exposure time, selected by software

T2: Frame Interval (1/Frame Rate), selected by software

Synchronisation Output

Logic 1 during Exposure Time (T1)

External Synchronisation Timing

Synchronisation Input “level detection”

positive level:

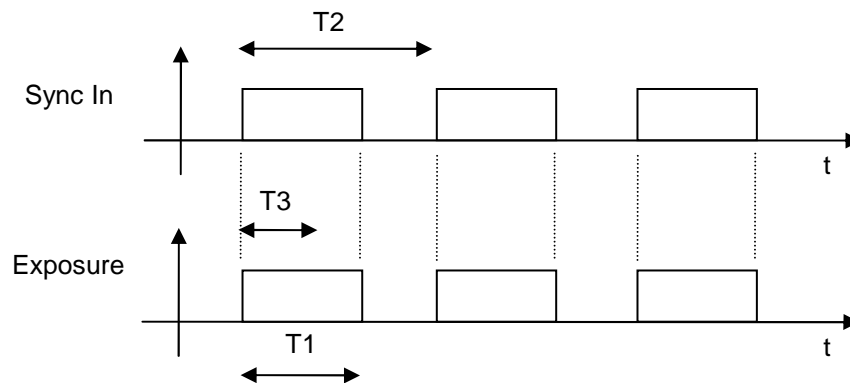

Sync In rising level to Exposure Delay: ~6,0usec +/- 530nsec typical

T1: Exposure time

T2: 1/Frame Rate

T3: 1/Maximum Frame Rate (limited by readout of the sensor)
depends on frame format and Camera Link® mode

<u>T1>T3:</u>	<u>T1<T3:</u>
T1 max: : no limit < 1sec recommended due to shutter efficiency and thermal noise T2 max: no limit < 1sec recommended due to shutter efficiency and thermal noise T2 min: T1	T1 max: : no limit < 1sec recommended due to shutter efficiency and thermal noise T2 max: no limit < 1sec recommended due to shutter efficiency and thermal noise T2 min: T3

Synchronisation Output “level detection”

Logic 1 during Exposure Time (T1)

Focal Length Calculation

Full Sensor Resolution

The required focal length of the lens at full sensor resolution (5120x5120 Pixel) is calculated as follows:

$$Focal\ Length\ [mm] = \frac{A}{1 + \frac{B}{32,583}}$$

A: Distance from lens to object in mm

B: Size of the object in mm

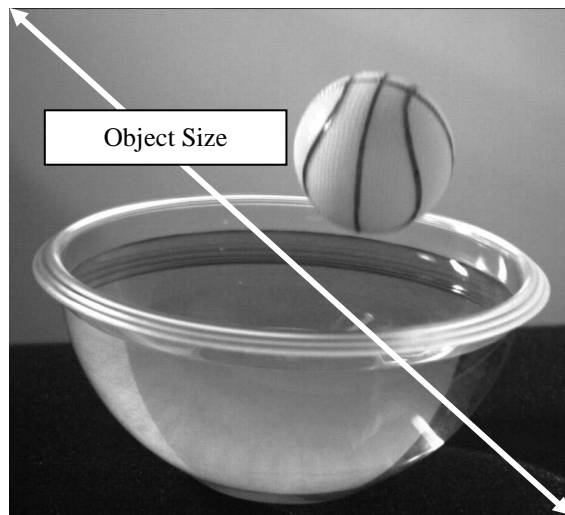

Example:

A: Distance from lens to object = 300 mm

B: Object Size = 100 mm

calculated focal length = (300 : (1 + (100 : 32,583))) = 73,7 mm

Reduced Sensor Resolution

At reduced sensor resolutions (e.g. 1920 horizontal x 1080 vertical pixels) the focal length is calculated as follows:

$$Sensor\ Size\ [mm] = 0,0045 \cdot \sqrt{C^2 + D^2}$$

$$Focal\ Length\ [mm] = \frac{A}{1 + \frac{B}{Sensor\ Size\ [mm]}}$$

- A: Distance from lens to object in mm
- B: Object size in mm
- C: Number of horizontal pixels
- D: Number of vertical pixels

Example:

- C: Number of horizontal pixels = 1920
- D: Number of vertical pixels = 1080

$$\text{Sensor Size [mm]} = 0,0045 \cdot \sqrt{1920^2 + 1080^2} = 9,9$$

- A: Distance from lens to object = 300 mm
 - B: Object size = 100 mm
- calculated focal length = $(300 : (1 + (100 : 9,9))) = 27 \text{ mm}$

when a lens with focal length of 35 mm has to be used, and the object size has to be kept at 100 mm, the distance from lens to object has to be changed as follows:

$$\text{Distance to Object [mm]} = \text{Focal Length} \cdot \left(1 + \frac{\text{Object Size}}{\text{Sensor Size}} \right)$$

at a focal length of 35mm, an object size of 100mm and a sensor size of 15,4mm the new distance from lens to object is calculated as:

$$35 \cdot (1 + (100 : 9,9)) = 388 \text{ mm}$$

The distance from lens to object has to be increased from 300mm to 388mm.

Vice versa, when the distance from lens to object has to be reduced, the focus of the lens will come to its limit. and the required magnification factor can no more performed by the lens itself. In this case, a distance washer has to be placed between the lens interface of the camera and the lens.

Distance Washer

The length of the distance washer can be calculated as follows:

$$\text{Length of the Distance Washer [mm]} = \text{Focal Length} \cdot \frac{\text{Sensor Size}}{\text{Object Size}}$$

Example:

Sensor Size as calculated above = 9,9mm

required Object Size=9,9mm

(The required magnification factor is = 1 : 1)

focal length of the lens = 35mm

calculated Length of the Distance Washer = 35 · (9,9 : 9,9) = 35mm

Camera firmware update

Camera firmware update is available through the USB programming cable and the CXP_Flash_Consumer software (located in the CXPFlash_Setup folder) delivered with the camera.

Please go through the following steps :

- 1) Switch OFF camera
- 2) Connect USB cable to PC and camera Aux. input.
- 3) Install USB driver on PC if it is not already done.

To install USB driver, launch USB_Setup.exe (located in the CXPFlash_Setup folder) and then Reboot PC.

- 4) Switch ON camera
- 5) Launch CXP_Flash_Consumer.exe

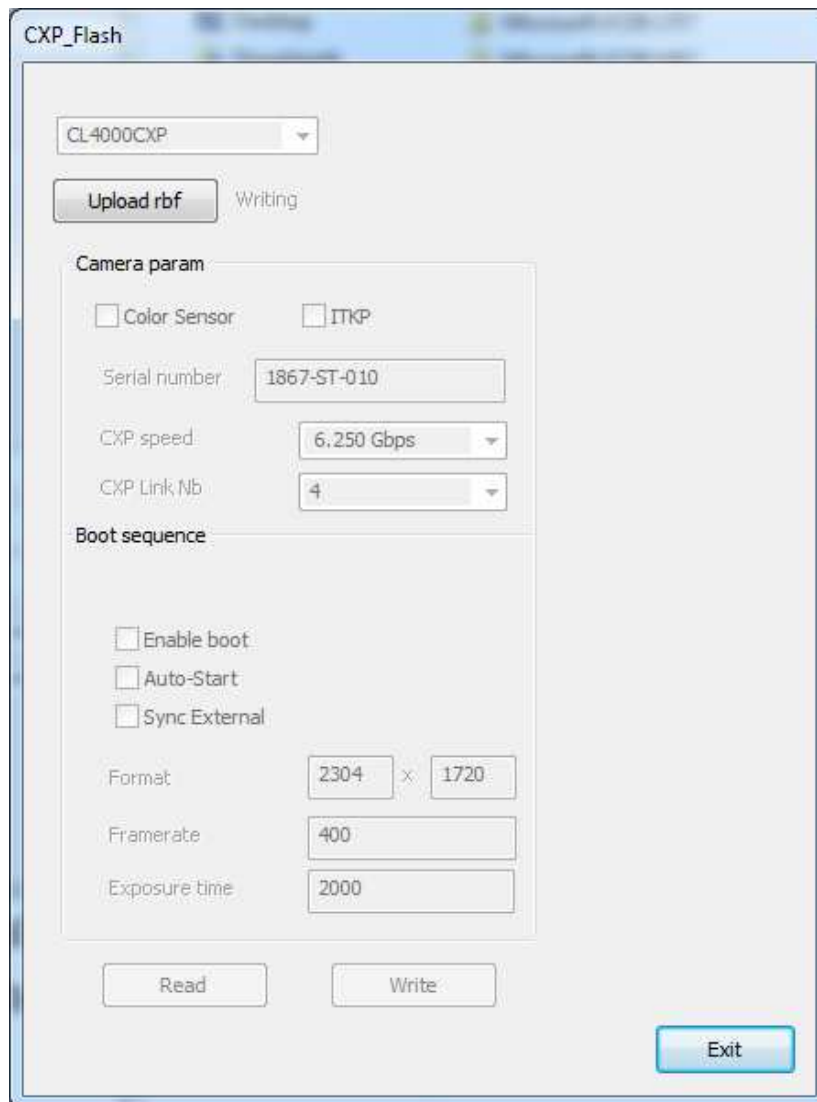

Click on "Upload rbf" and select the file cxp9xxx.rbf.
Wait until finished.

- 6) Click on Exit.
- 7) Switch OFF camera and switch ON camera.

Camera mapping

This part is an extract of the GenICam xml file.

Addresses are given in hexadecimal format and Length is given in bytes.

The hexadecimal mask (if specified) gives the bytes that can be accessed.

Access types : RO (Read Only), RW (Read and Write)

DeviceVendorName

Name of the manufacturer of the device.

Address : 0x2000

Length : 32

Access : RO

DeviceModelName

This feature provides the model of the device

Address : 0x2020

Length : 32

Access : RO

DeviceManufacturerInfo

This feature provides extended manufacturer information about the device

Address : 0x2040

Length : 48

Access : RO

DeviceVersion

This feature provides the version of the device

Address : 0x2070

Length : 32

Access : RO

DeviceFirmwareVersion

Version of the firmware in the device

Address : 0x2090

Length : 32

DeviceID

This feature stores a camera identifier

Address : 0x6028

Length : 16

Access : RO

DeviceReset

Resets the device to its power up state. Write 0x1 to reset the device.

Address : 0x4000

Length : 4

Access : RW

WidthMax

Maximum width (in pixels) of the image

Address : 0x6000

Length : 4

Mask : 0xFFFF0000

Access : RO

Width

This feature represents the actual image width expelled by the camera (in pixels).

Minimum : 256

Increment : 256

Maximum : WidthMax

Address : 0x6000

Length : 4

Mask : 0x0000FFFF

Access : RW

HeightMax

Maximum height (in pixels) of the image

Address : 0x6004

Length : 4

Mask : 0xFFFF0000

Access : RO

Height

This feature represents the actual image height expelled by the camera (in pixels).

Minimum : 4

Increment : 4

Maximum : HeightMax

Address : 0x6004

Length : 4

Mask : 0x0000FFFF

Access : RW

OffsetX

Horizontal offset from the origin to the area of interest (in pixels)

Minimum : 0

Increment : 256

Maximum : WidthMax-Width

Address : 0x60D0

Length : 4

Access : RW

OffsetY

Vertical offset from the origin to the area of interest (in pixels)

Minimum : 0

Increment : 4

Maximum : HeightMax-Height

Address : 0x60D4

Length : 4

Access : RW

PixelFormat

This feature indicates the format of the pixel to use during the acquisition

Write 0x0101 for Mono8 format (8-bits monochrom)

Write 0x0102 for Mono10 format (10-bits monochrom)

Address : 0x60F0

Length : 4

Access : RW

AcquisitionMode

This feature controls the acquisition mode of the device

Write 0x00 for continuous trigger (Continuous)

Write 0x01 for external trigger (SingleFrame)

Write 0x02 for trigger over CoaxPress (CoaxPress)

Address : 0x6018

Length : 4

Mask : 0x000000FF

Access : RW

AcquisitionStart

This feature starts the Acquisition of the device

Write 0x01 to start acquisition.

Write 0x00 to stop acquisition.

Address : 0x601C

Length : 4

Mask : 0x000000FF

Access : RW

AcquisitionFrameRate

Frame rate in Hz

Minimum : 16

Increment : 1

Maximum : AcquisitionFrameRateMax

Address : 0x6008 (for integer values), 0x60C0 (for floating values)

Length : 4

Access : RW

AcquisitionFrameRateMax

Maximum frame rate in Hz

Address : 0x600C (for integer values), 0x60C4 (for floating values)

Length : 4

Access : RO

ExposureTime

Sets the Exposure time (in microseconds) when ExposureMode is Timed

Minimum : 98

Increment : 1

Maximum : ExposureTimeMax

Address : 0x6010 (for integer values), 0x60C8 (for floating values)

Length : 4

Access : RW

ExposureTimeMax

Maximum Exposure time (in microseconds) when ExposureMode is Timed

Address : : 0x60BC (for integer values), 0x60CC (for floating values)

Length : 4

Access : RO

GranularityMode

Write 0x01 to activate Granularity mode. In that mode, exposure time is set by register (ExposureTime) when using external triggering or trigger over CoaxPress

Write 0x00 to deactivate Granularity mode

Address : 0x6018

Length : 4

Mask : 0x0000FF00

Access : RW

ShutterMode

Select Global shutter mode or rolling shutter mode.

Warning : in rolling shutter mode, acquisition mode can only work in continuous mode.

Write 0x01 to select Global shutter mode.

Write 0x00 to select Rolling shutter mode.

Address : 0x6180

Length : 4

Mask : 0x000000FF

Access : RW

FlashSaveWithAutoStart

This feature saves the current configuration into flash. After reboot, the camera loads the saved configuration and starts the acquisition automatically.

FlashSaveWithoutAutoStart

This feature saves the current configuration into flash. After reboot, the camera loads the saved configuration without starting the acquisition automatically.

DisableFlashLoad

This feature disables the flash configuration load at the camera boot.

IndicatorLamps

Switch ON/OFF indicator lamps.

Write 0x00 to switch ON the indicator lamps.

Write 0x01 to switch OFF the indicator lamps.

Address : 0x601C

Length : 4

Mask : 0x00FF0000

Access : RW

ColorSensor

Has camera a color sensor.

Return 0x1 for a color sensor and 0x0 for a monochrom sensor

Address : 0x6038

Length : 4

Access : RO

Gen<i>Cam

Optronis ships together with the CP80-25-M/C-72 camera a XML file that is Gen<i>Cam compatible. The XML file follows the SNFC (Standard Features Naming Convention).

Please ask, if needed, the Optronis customer service for the availability of this XML file.

