



i

microEnable 5 marathon ACX-DP

Product Profile of microEnable 5 marathon ACX-DP

Scalable, intelligent high performance frame grabber for highest requirements on image acquisition and preprocessing by new generation standard

- ◆ Support of fastest CoaXPress camera input
- ◆ Easy-to-use configuration software
- ◆ High performance image acquisition
- ◆ Industrial multi-device, multi-camera support
- ◆ DMA 1800 / up to 1800 MB/s PCIe Data bandwidth (PCIe x4 Gen2)
- ◆ Supports opto-decoupled signals via front I/O
- ◆ Broad support of Third-party software interfaces
- ◆ Versatile application and industry usage
- ◆ Flexible and extensible model series
- ◆ Power over CoaXPress



Technical Description

Advanced microEnable 5 marathon frame grabber with 2* CoaXPress ports (DIN 1.0/2.3) up to for 2* independent CXP-6® cameras, 512 MB DDR3RAM acquisition and image processing buffer, Xilinx Kintex 7 system processor, PCIe x4 (Gen 2) bus interface, DMA1800 technology. Documentation, SDK, supporting software tools, functional libraries with acquisition applets and drivers in delivery.

Article Details

Product Name	microEnable 5 marathon ACX-DP
Match Code	mE5-MA-ACXDP
Article No.	150503
Category	A-Series (image acquisition board)

Device Features

Processor	System Processor
On Board Memory	1 GByte DDR3-RAM
Processor Board Interface	n/a
Data Forwarding	n/a
I/O Module Interfaces	Trigger/GPIO-IF (Opto Trigger, TTL Trigger)



Camera Interface

Standard	CoaXPress 1.0/1.1
Configurations	CXP-1, CXP-2, CXP-3, CXP-5, CXP-6; up to 2 cameras
Connectors	2* DIN 1.0/2.3
Cable Length	standard conform
Power Output	Power over CXP 13W/24V per cable, SafePower
Camera Support	Area scan camera, line scan camera
Sensor Type	Grayscale sensor, CFA sensor (Bayer), RGB sensor
Sensor Resolution	16k*64k (area scan sensor), 32k (line scan sensor)
Bit Depth	8-16-bit (grayscale), 24-48-bit (color)
Data Bandwidth	2* 6,25 Gbit/s
Test Environment	Camera Simulator

Controls and General Purpose I/Os

Trigger Board GPIO Interfaces	TTL Trigger board: 8 TTL in and 8 TTL out, max. input freq: 20 MHz; Opto Trigger boards (options): Up to 8 single-ended opto-coupled in (4,5V-28V) or 4 differential opto-coupled in (4,5-28V, RS422 compliant); 8 opto-coupled out (4,5V-28V), max. input freq: 1 MHz
On-board GPIO Interface	4 opto-coupled inputs (4,5 V -28 V), optional 2 opto-coupled differential inputs (RS422); 4 opto-coupled outputs (4,5 – 28 V); Shaft encoder input, programmable rescaler, multiple-camera synchronization
On-board Front GPIO Interface	2 opto-coupled differential inputs (RS422) and 1 opto-coupled differential / single ended input; optional (conf.): 4 opto-coupled Inputs (4,5 V -28 V) with up to 1 MHz frequency; 2 TTL outputs, up to 20 MHz frequency; shaft encoder input, programmable rescaler: multiple-camera synchronization; RS485 interface (PLC connection) scheduled
Synchronization and Control	Configurable Trigger System supporting several trigger modes (grabber controlled, external trigger, gated, software trigger) and shaft encoder functionality with backward compensation, Multi-Camera-Synchronization
GPIO Summary	8in/8out (max.), TTL or opto-coupled



Host PC Interface

PC Bus Interface	PCI Express x4 (Gen 2), DMA1800
PC Bus Interface Performance	up to 1.800 MB/s (sustainable)

Physical and Environmental Information

Dimensions	PCIe Standard height, half length card: 167.64 mm length x 111.15 mm height
Approximate Weight	tbd
Power Consumption / Power Source	typ. 0.96 A @ 12V (actual values depend on processing), max load ca. 2.15 A
Operating Temperature	50° (0 LFM*), 60° (100 LFM*) FPGA operating temperature: 0°C to 85°C *LFM = Linear Feet per Minute, unit for measuring airflow velocity
Storage Temperature	'-50°C up to 80°C
Relative Humidity	5% - 90% non-condensing (operating), 0% - 95% (storage)
MTBF	pending
Compliances	CE, RoHS, WEEE, REACH

Software

Software Drivers	Windows 7 / 8 / 10 (32-bit), Windows 7 / 8 / 10 (64-bit), Linux 32-bit, Linux 64-bit
Software Tools	microDisplay (Acquisition control and viewer), microDiagnostics (Service tool), GenICam Explorer (Camera configuration tool), SDK, Documentation, Device Drivers
Software API	Silicon Software SDK, .net interface
FPGA Programming	not programmable
BV Software Compatibility	Common Vision Blox, Halcon, Cognex, Labview others on request

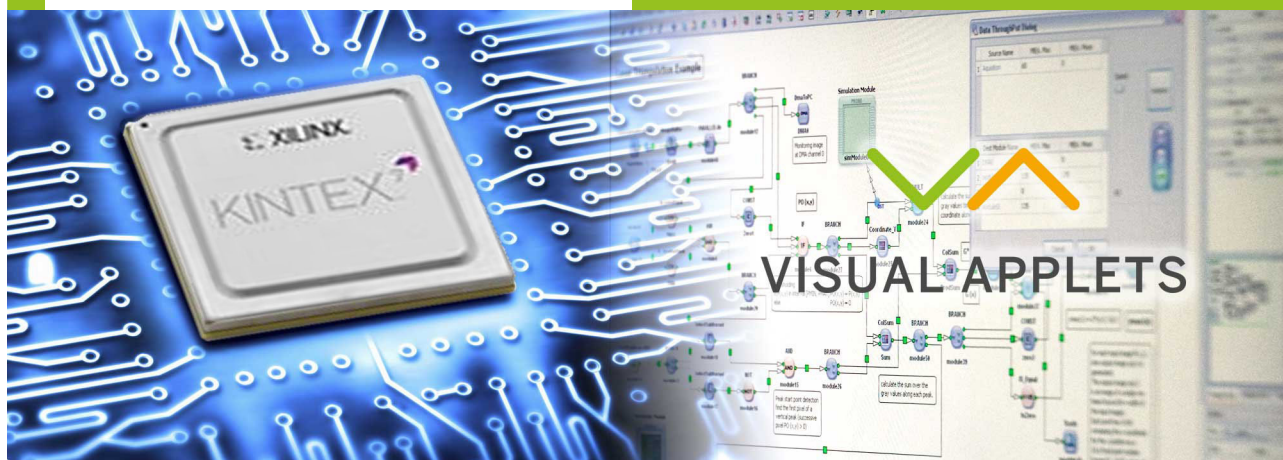

VisualApplets

Often, the goal of industrial image processing applications is to find 100% of all errors and to work in high resolution to identify even the smallest details, to acquire images in the shortest time possible, to detect defects and to forward the results. These tasks frequently require more computing power than a “standard system” can offer. There are solutions that begin the image processing right after the acquisition process but before the camera images are written to storage and taken over by the software.

The processors used in such solutions are designed for image processing. They process data with extremely high parallelism, thus guaranteeing the necessary data throughput. On all its frame grabbers, Silicon Software uses this FPGA technology. In the A-Series (frame grabbers with expanded image recording functions), we have already programmed important and valuable functions that can be activated via the configuration software. For V-Series models (programmable frame grabbers for individual image processing functions), we have released the FPGA for you, as our customer, for individual programming.

To ease your entry into hardware programming, we have developed software that enables you to graphically program FPGAs using data flow diagrams. This program is called VisualApplets.

VisualApplets makes it possible for you to write complex applications on your own, even after a short time, for the special processor. Even without hardware programming expertise. The program is geared toward both software programmers and application engineers. Program in the language of image processors without using hardware code. The simulation works with a rapid image output with which you can immediately check your algorithms and image processing steps.

We have built in many automatic correction functions and generators so that you can concentrate on your actual work. And should an error sneak in, you are immediately made aware of it in color, and solution approaches are offered to you.

An SDK output generates executable example code in C/C++, listing all the parameters (hardware register), in order to control the image processing application out of your software.

What does real time mean? By using FPGA technology, you have a deterministic relationship to the application that works after the start with a constant delay (latency) that is determined by the image processing algorithm. In most cases, this latency lies in the micrometer range.

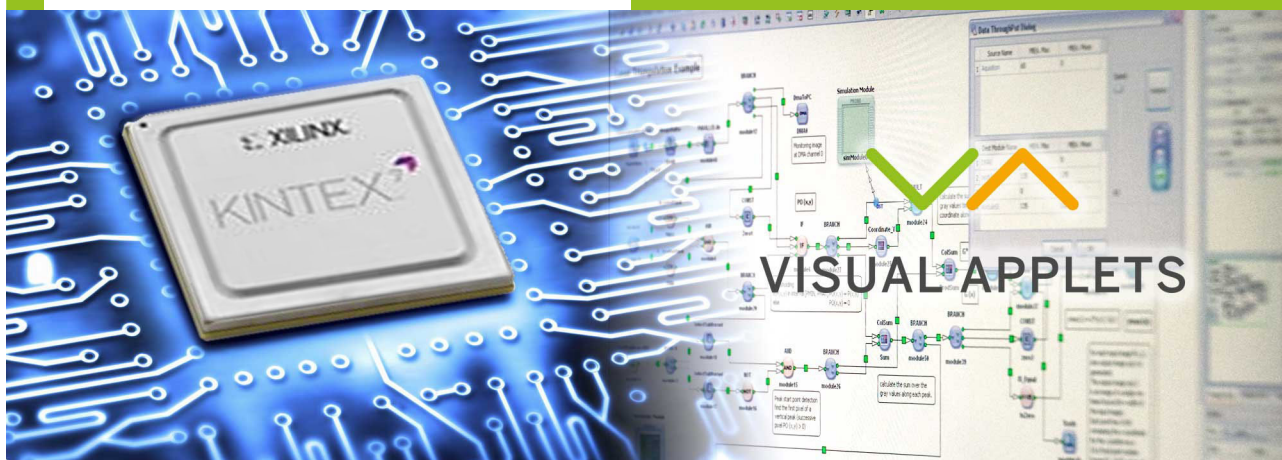

VisualApplets (ctd.)

VisualApplets simplifies image processing programming for you. You can fall back on libraries with over 200 operators. You can create your own libraries for commonly used image processing steps or import them from available hardware code (EDIF over VHDL/Verilog).

With VisualApplets, you acquire a powerful tool that offers you new ways forward for your system solution.

VisualApplets is available for Silicon Software V-Series frame grabbers, including VisualApplets-compatible cameras and imaging devices.

V-Series frame grabbers are already pre-licensed for use with VisualApplets in the basic version. VisualApplets offers several versions of its programming environment; additionally, you can license further operator libraries to expand the range of functions.

In 2006, VisualApplets was honored with the international Vision Award. It has been successfully used in the most diverse industrial applications, both using frame grabbers and in VisualApplets-compatible industrial cameras and image processing devices.

Technical Setup

Board/Housing Measurement

Height: 111,15 mm
 Length: 167,64 mm
 Width: no width
 Mounting: PCIe slot
 Screw Mounting: no screw mounting
 Protection Class: no class defined
 Material: PCB, RoHS compliant
 Screws: no screws

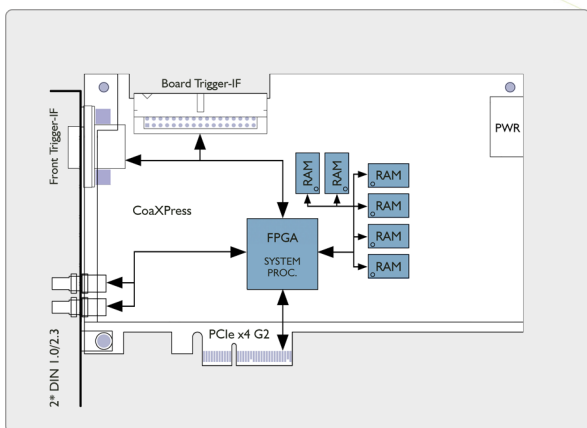
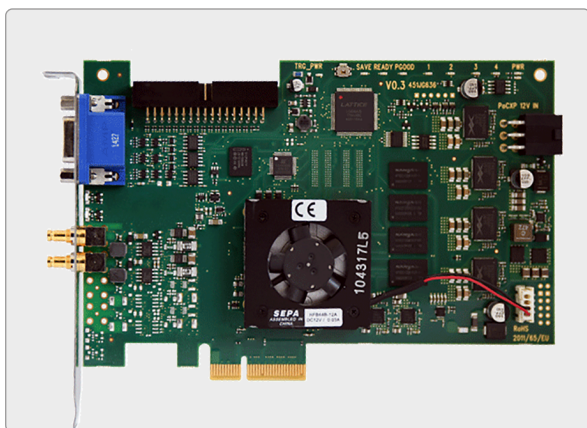

PRODUCT VARIATIONS

microEnable 5 marathon ACX-QP
 microEnable 5 marathon ACX-SP
 microEnable 5 marathon VCX-QP

PRODUCT EXTENSIONS

Opto-coupled Trigger Board – mE5, Match Code: TRG-
 OPT05, Art.No.: 155010
 TTL Trigger Board – mE4, Match Code: TRG-TTL4, Art
 No.: 101250

ORDERING INFO

- ◆ microEnable 5 marathon ACX-DP,
 mE5-MA-ACXDP, Art No.: 150503



Copyright © Silicon Software, 2019

Generated on 11. March 2019



Silicon Software GmbH
Konrad-Zuse-Ring 28
68163 Mannheim
Germany

[t] +49.621.798507-0
[f] +49.621.798507-10
[e] info@silicon.software
[w] <https://silicon.software>



Silicon Software Inc
1 Tara Boulevard, Suite 200
Nashua, NH 03062
USA

[t] +1.888.808 3670
[f] +1.888.808 3670
[e] americas@silicon.software
[w] <https://silicon.software>



Silicon Software Americas Inc
3055 St-Martin Blvd., Suite 500
Laval, Qc., H7T0J3
Canada

[t] +1.888.808 3670
[f] +1.888.808 3670
[e] americas@silicon.software
[w] <https://silicon.software>

We reserve the right of technical modifications, changes of the equipment features and adaptations to current specification. Typing and setting mistakes and other errors cannot be excluded and are therefore also reserved. In recent publications availability, also by technical generation, previous cease to be valid.