SILICON SOFTWARE

A-Series GigabitEthernet

microEnable IV AQ4-GPoE

Quad port PCIe frame grabber for GigE Vision with PoE support

The microEnable IV AQ4-GPoE is a quad-port frame grabber for four independent GigE Vision cameras with Power over Ethernet support.

All integrated image acquisition and image pre-processing functions of the microEnable IV VQ4-GPoE are executed on the system FPGA in real time, and offer high performance and robust and reliable acquisition technology at the same time.

Whenever a professional environment for GigabitEthernet based system is required, microEnable IV AQ4-GPoE will guarantee an industrial use with comprehensive Machine Vision features. On-board image reconstruction will reduce the interrupt load of the system and the load by memory transfer. The host-CPU is dramatically unburdened. Among others, optimized drivers and the use of jumbo packets help to work with a secure and fail-save image processing system and industrial performance. With its wide range of additional functionality and essential functions, microEnable IV AQ4-GPoE enables the professional use of GigabitEthernet in the Machine Vision industry, which was well-known from Camera Link environments. Digital interfaces for signal input and output allow for a control of external devices with low latencies, and a Software Development Kit (SDK) tailored for Machine Vision enables the comfortable integration of application of your own.

Product Features	
✓	Acquisition Buffer
▶	256 MB DDR-RAM
✓	FPGA System Processor
	FPGA Vision Processor
	Xilinx Spartan 2
	Xilinx Spartan 3
✓	Sustainable Transfer Rate (max.)
▶	760 MBytes/sec.

Camera Interface	
	Camera Link
	Power over Camera Link
✓	GigE Vision

GigabitEthernet Standards	
✓	GigE Vision
✓	Gen<i>Cam
✓	Power over Ethernet (PoE)
✓	Link Aggregation (in preparation)

Camera Interface	
	Camera Link Connectors
	MDR26
	SDR26
✓	GigabitEthernet Connectors
	RJ45
	4 RJ45 with PoE Support

PC Interface	
	PCI 32/64bit
✓	PCI Express
	PCIe x1 (single lane)
▶	PCIe x4 (quad lanes)

Connectivity Features	
✓	GPIO/Trigger Connector
	PixelPlant Connector
	CLIO Connector

Acquisition Features	
	Camera Pixel Clock Support
	85 MHz
✓	Area Scan Cameras
▶	8k * 4k max. image size
✓	Line Scan Cameras
▶	16k max. image width
✓	Grayscale Cameras
▶	8bit resolution
▶	16bit resolution
✓	Color Cameras
▶	24bit resolution (RGB)
▶	48bit resolution (RGB)
▶	24bit resolution (Bayer CFA)
▶	36bit resolution (Bayer CFA)
	Mixed Mode (requires VisualApplets)
	Area Scan + Line Scan Cameras
	Grayscale + Color Cameras
	Arbitrary Combinations

AddOn Products	
✓	GPIO Boards
✓	GPIO Boards, opto-isolated
	CLIO (Camera Link Replicator)
	PixelPlant (Processing Extension)

Physical Board Properties	
▶	168 mm length x 111 mm height
▶	Operating temperature 0°C - 40°C

Any information without obligation. Technical specifications and scope of delivery are liability-free and valid until revocation. Mistakes are excepted.



Image Acquisition Features

- Synchronous Acquisition Process
- Multi-Camera Acquisition Ability
- Knee Lookup Table
- Basic Image Processing, e. g. Brightness, Contrast and Gamma Correction
- Real-Time Bayer Conversion
- Internal 16bit Processing
- Regions of Interest (ROI)
- Hardware Generated Image Number
- Reads Gen<i></i>Cam Configuration
- Highly Customizable I/O System
- Dig I/O Signals

... and further ones

Special Features

- Support of Jumbo Packets (*future feat.*)
- Automatic Image Reconstruction from Data Packets
- Reduction of Interrupt Load to 1 IRQ/img
- 0% CPU Load

... and further ones

Software Products

- ✓ Device Drivers
- ✓ Firmware Flasher
- ✓ microDisplay
- ✓ microDiagnostics
- ✓ GigE Explorer
- ✓ microEnable SDK

Processing Libraries

incl.	AcquisitionApplets
	SmartApplets Base
	SmartApplets Extended
	VisualApplets Base
	VisualApplets Blob
	VisualApplets Compression

Processing Licenses (Base version)

- SmartApplets enabled
- VisualApplets enabled

Operation Systems

✓ Windows XP	32bit	64bit
✓ Windows Vista	32bit	64bit
✓ Windows 7	32bit	64bit
✓ Linux (Kernel 2.6.23+)	32bit	64bit

Hardware/Software Compatibility

new product line

Required Accessory

- ✓ Power Supply (48V), internal, 30W

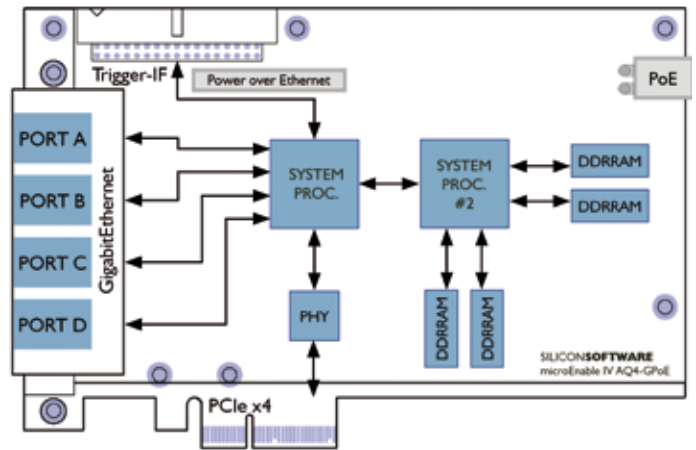

Schematic layout of microEnable IV AQ4-GPoE

Supported Features Sorted by Hardware Applets for

microEnable IV AQ4-GPoE

		Quad Area Bayer 24	Quad Area Gray 8	Quad Area Gray 16	Quad Area RGB 24	Quad Line Gray 8	Quad Line Gray 16	Quad Line RGB 24
Camera Support	GigE Vision	■	■	■	■	■	■	■
	Gen<i></i>Cam	■	■	■	■	■	■	■
Camera Type	Area Scan / Line Scan	A	A	A	A	L	L	L
	GrayScale / RGB / Bayer	BAY	G	G	RGB	G	G	RGB
	Supported Cameras	4	4	4	4	4	4	4
Color Processing	White Balancing	■						
	Bayer Bilinear Algorithm	■						
	Look-up Table		■					
Image Enhancement	Image Enhancements		■					
	Median Filter		■					■
	Image Processing		■					■
Image Correction	Image Format Reconstruction	■	■	■	■	■	■	■
	Signal Control	■	■	■				
Performances	Digital input signals	2	2	2				
	Digital output signals	2	2	2				
	I/O boards opto/TTL available	■	■	■	■	■	■	■
Image Formats	Max. width [in k pixels]	4	8	8	8	16	16	16
	Max. height [in k lines]	8	4	4	4	16	16	16
	Gray8 (8bit output)		■			■		
	Gray16 (16bit output)			■			■	
	RGB 24 (3x8bit output)	■			■			■

Any information without obligation. Technical specifications and scope of delivery are liability-free and valid until revocation. Mistakes are excepted.

