



Technical Details



# DFK 33UP2000 Technical Reference Manual



<b>1. Quick Facts</b>	<b>4</b>
<b>2. Dimensional Diagrams</b>	<b>6</b>
2.1 DFK 33UP2000 C-Mount with Tripod Adapter .....	6
2.2 DFK 33UP2000 C-Mount without Tripod Adapter .....	7
2.3 DFK 33UP2000 CS-Mount with Tripod Adapter .....	8
2.4 DFK 33UP2000 CS-Mount without Tripod Adapter .....	9
<b>3. I/O Connector</b>	<b>10</b>
3.1 12-pin I/O Connector .....	10
3.1.1 TRIGGER_IN .....	11
3.1.2 STROBE_OUT .....	11
<b>4. Spectral Characteristics</b>	<b>12</b>
4.1 IR-Cut Filter .....	12
4.2 Spectral Sensitivity - P2000 .....	12
<b>5. Camera Controls</b>	<b>13</b>
<b>5.1 Sensor Readout Control</b> .....	<b>13</b>
5.1.1 Pixel Format .....	13
5.1.1.1 8-Bit Bayer Raw .....	14
5.1.1.2 10-Bit Packed Bayer Raw .....	14
5.1.1.3 YUV 4:1:1 .....	14
5.1.1.4 8-Bit Monochrome .....	14
5.1.2 Resolution .....	15
5.1.3 Readout Modes .....	15
5.1.4 Frame Rate .....	16
5.1.5 Partial Scan Offset .....	18
<b>5.2 Image Sensor Control</b> .....	<b>19</b>
5.2.1 Exposure Time .....	19
5.2.2 Gain .....	19
<b>5.3 Automatic Exposure and Gain Control</b> .....	<b>19</b>
5.3.1 Auto Exposure .....	20
5.3.2 Auto Gain .....	20
5.3.3 Auto Reference Value .....	20
5.3.4 Highlight Reduction .....	21
5.3.5 Auto Exposure Limits .....	21
5.3.6 Auto Gain Limits .....	22
<b>5.4 Trigger</b> .....	<b>23</b>
5.4.1 Trigger Mode .....	23
5.4.2 Trigger Polarity .....	23
5.4.3 Software Trigger .....	24
5.4.4 Trigger Burst Count .....	24



5.4.5	Trigger Source .....	24
5.4.6	Trigger Overlap .....	25
<b>5.5</b>	<b>Trigger Timing Parameters .....</b>	<b>25</b>
5.5.1	Trigger Delay .....	25
5.5.2	Trigger Debounce Time .....	26
5.5.3	Trigger Mask Time .....	26
5.5.4	Trigger Noise Suppression Time .....	26
<b>5.6</b>	<b>Digital I/O .....</b>	<b>27</b>
5.6.1	General Purpose Input .....	27
5.6.2	General Purpose Output .....	27
<b>5.7</b>	<b>Strobe .....</b>	<b>28</b>
5.7.1	Strobe Enable .....	28
5.7.2	Strobe Polarity .....	28
5.7.3	Strobe Operation .....	29
<b>5.8</b>	<b>White Balance .....</b>	<b>29</b>
5.8.1	Auto White Balance .....	29
5.8.2	White Balance Mode .....	30
5.8.3	Manual White Balance .....	31
<b>5.9</b>	<b>Image Processing .....</b>	<b>33</b>
5.9.1	Gamma .....	33
5.9.2	Lookup Table .....	34
<b>5.10</b>	<b>Color Processing .....</b>	<b>35</b>
5.10.1	Hue .....	35
5.10.2	Saturation .....	35
<b>5.11</b>	<b>Region of Interest for Auto Functions .....</b>	<b>36</b>
5.11.1	Auto Functions ROI Enable .....	36
5.11.2	Auto Functions ROI Preset .....	36
5.11.3	Auto Functions ROI Custom Rectangle .....	37
<b>5.12</b>	<b>User Sets .....</b>	<b>38</b>
5.12.1	User Set Selector .....	38
5.12.2	Load User Set .....	38
5.12.3	Save User Set .....	39
5.12.4	Default User Set .....	39
<b>6.</b>	<b>Revision History .....</b>	<b>40</b>



## 1 Quick Facts

<b>General</b>	
Vision Standard	USB3 Vision
Dynamic Range	8/10
Resolution	1920x1200
Frame Rate	129
Pixel Formats	8-Bit Monochrome 8-Bit Bayer (BG) 10-Bit Bayer Packed (BG) YUV 4:1:1

<b>Optical Interface</b>	
IR-Cut filter	Yes
Sensor Type	ON Semiconductor P2000
Shutter Type	Global
Sensor Format	2/3 inch
Pixel Size	4.8 $\mu\text{m}$
Lens Mount	C/CS

<b>Electrical Interface</b>	
Interface	USB 3.0
Supply voltage	4.75 VDC to 5.25 VDC
Current consumption	approx 900 mA @ 5 VDC
I/O Connector	12-pin connector for trigger and strobe or general purpose input/output

<b>Mechanical Data</b>	
Dimensions	H: 29 mm, W: 29 mm, L: 43 mm
Mass	65 g

<b>Adjustments</b>	
Shutter	50 $\mu\text{s}$ to 10 s
Gain	0 dB to 32 dB



<b>Environmental</b>	
Temperature (operating)	-5 °C to 45 °C
Temperature (storage)	-20 °C to 60 °C
Humidity (operating)	20 % to 80 % (non-condensing)
Humidity (storage)	20 % to 95 % (non-condensing)



# Dimensional Diagrams

## 2 Dimensional Diagrams

### 2.1 DFK 33UP2000 C-Mount with Tripod Adapter

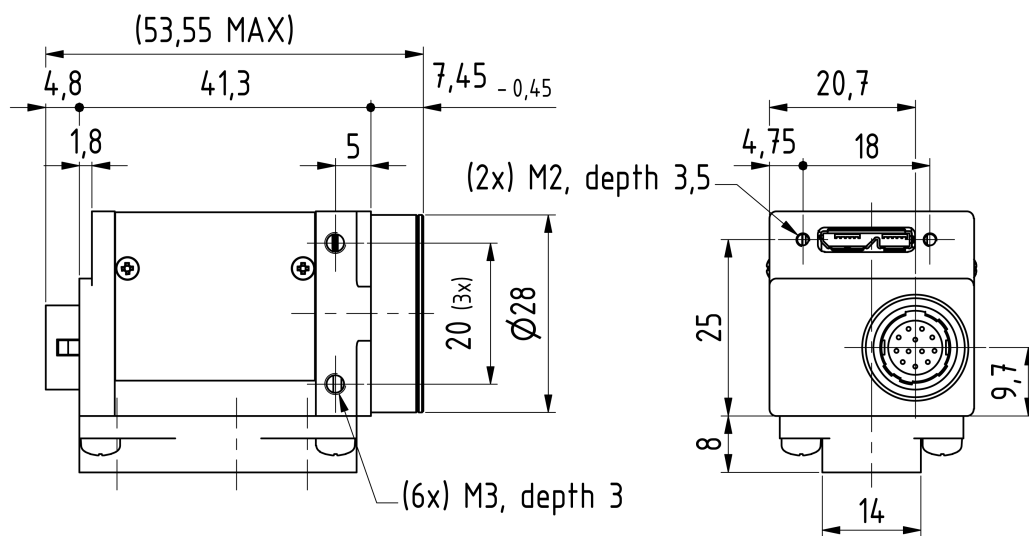
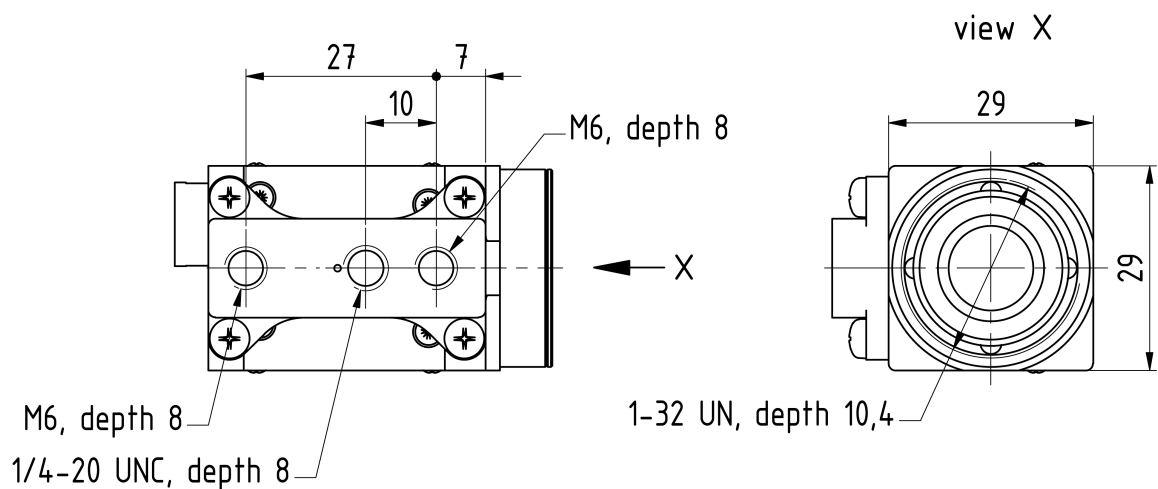

Dimensions: mm  
Tolerances: DIN ISO 2768-f

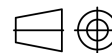



## 2.2 DFK 33UP2000 C-Mount without Tripod Adapter

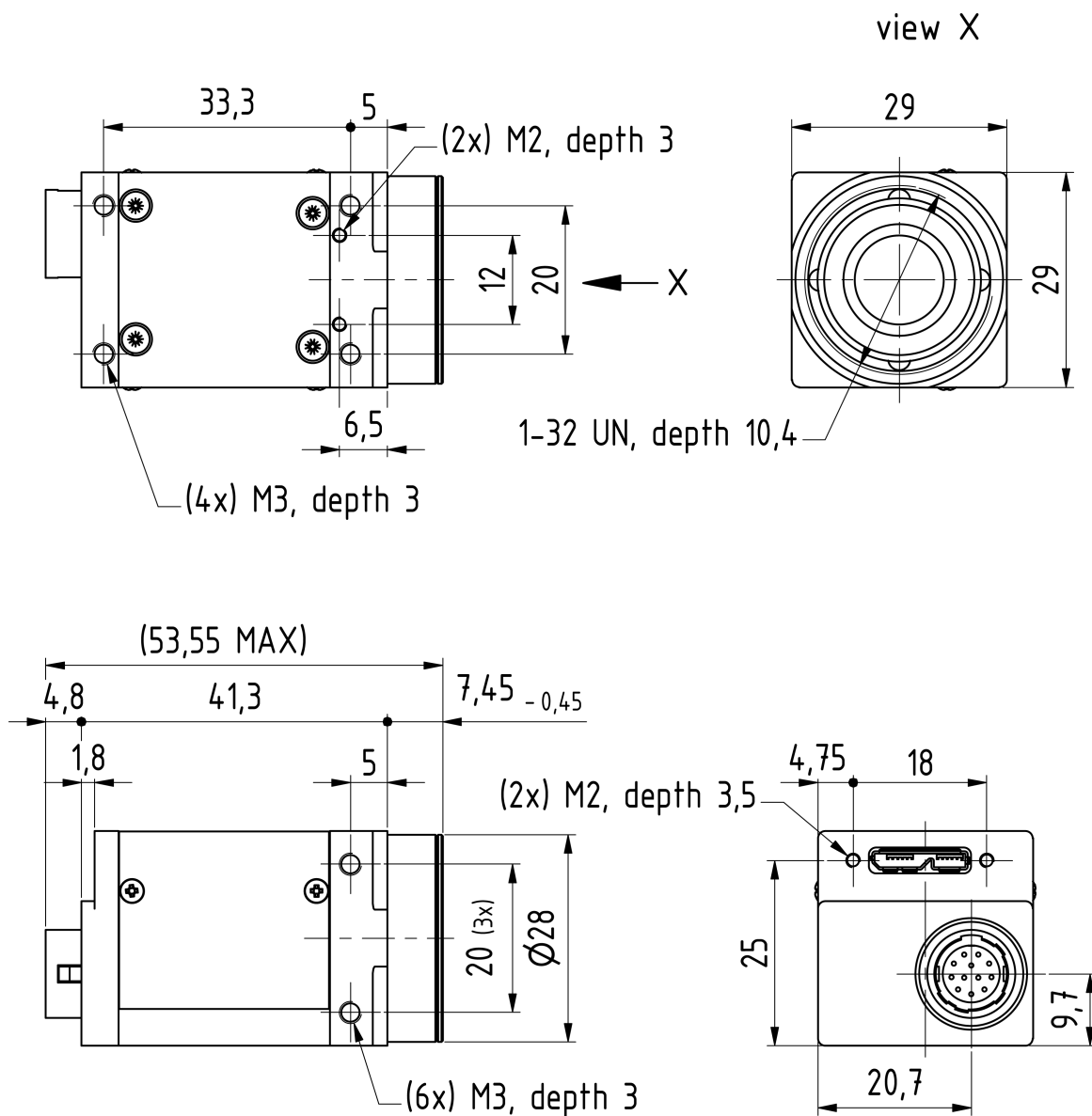

Dimensions: mm  
Tolerances: DIN ISO 2768-f

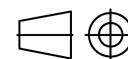



# Dimensional Diagrams

## 2.3 DFK 33UP2000 CS-Mount with Tripod Adapter

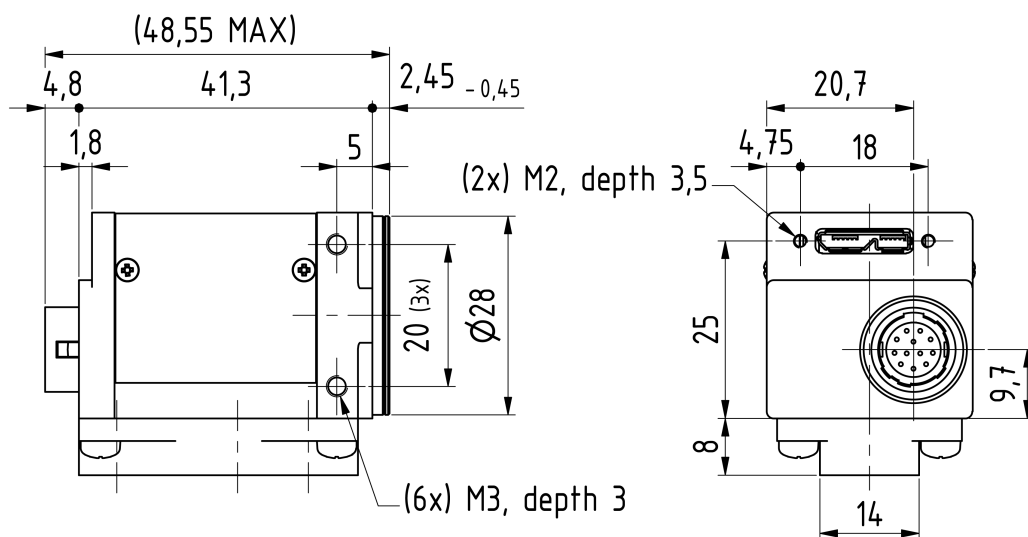
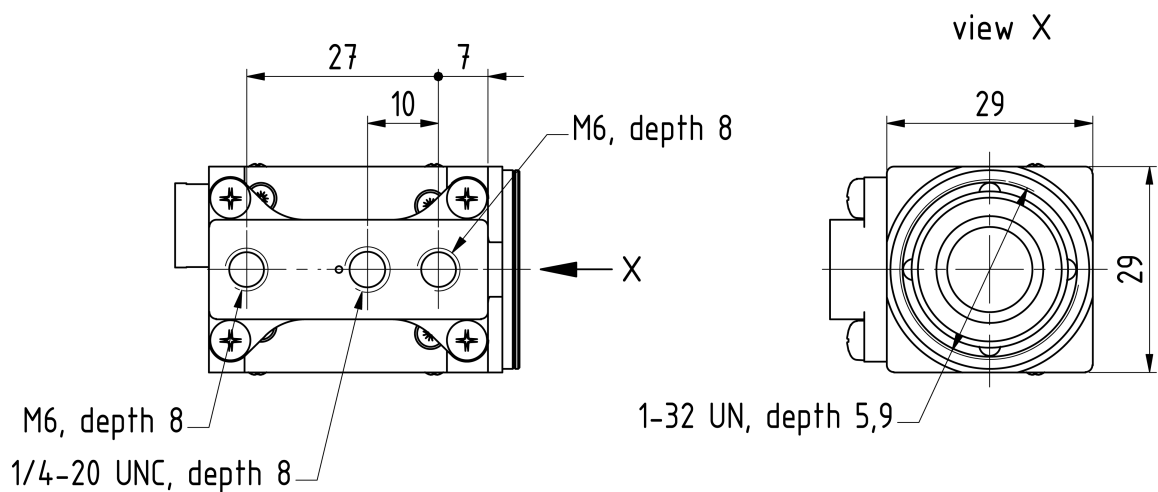

Dimensions: mm  
Tolerances: DIN ISO 2768-f







## 2.4 DFK 33UP2000 CS-Mount without Tripod Adapter

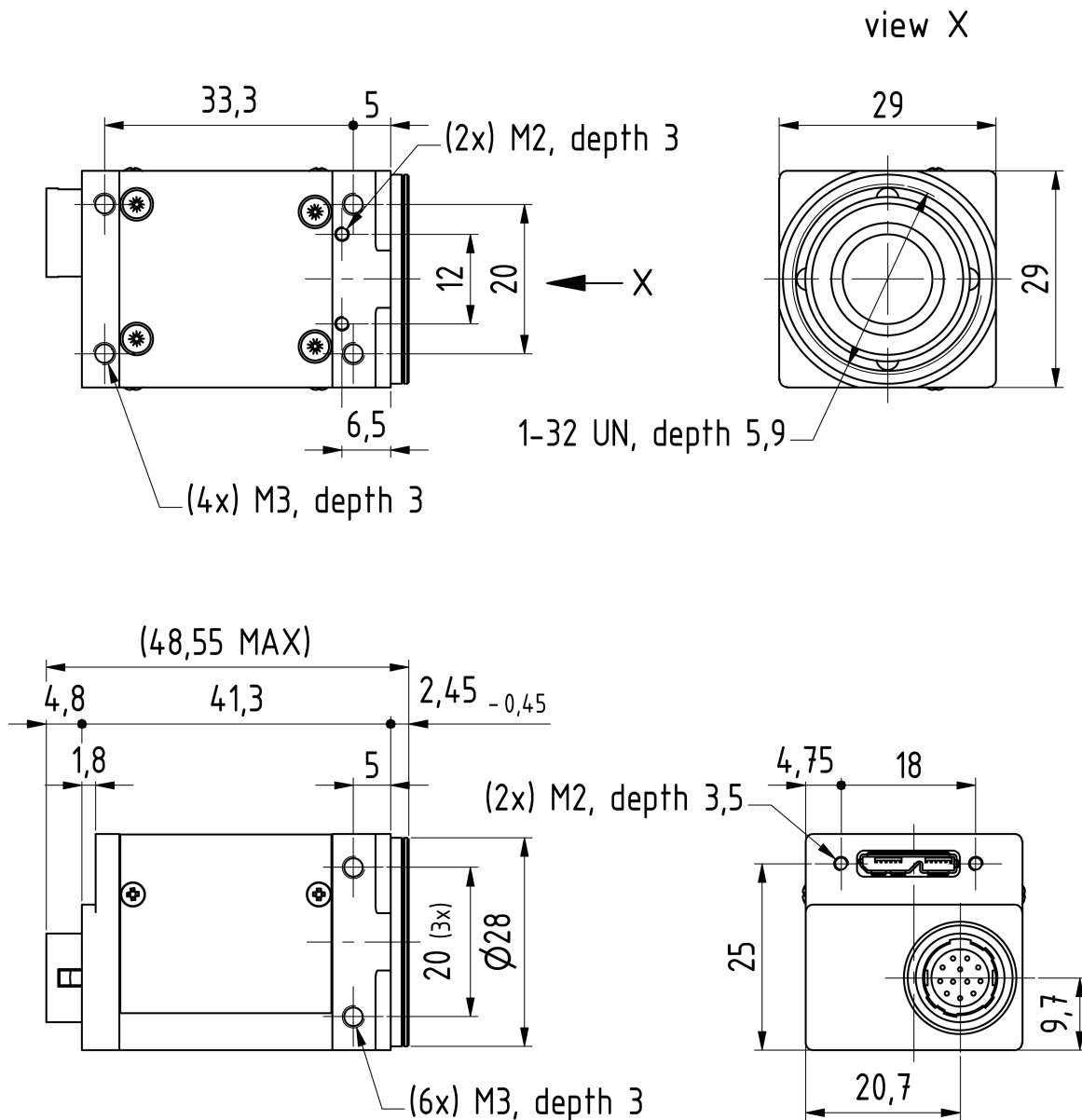

Dimensions: mm  
Tolerances: DIN ISO 2768-f

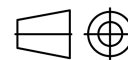



## 3 I/O Connector

### 3.1 12-pin I/O Connector

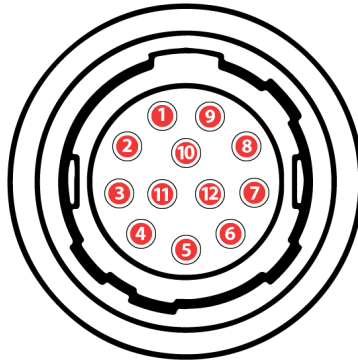

Rear view of camera

Pin	Signal	I/O	Remarks	Characteristics			
				Min	Typ	Max	Unit
1	do not use		-	-	-	-	-
2	do not use		-	-	-	-	-
3	n.c.		-	-	-	-	-
4	n.c.		-	-	-	-	-
5	n.c.		-	-	-	-	-
6	n.c.		-	-	-	-	-
7	GND_I/O	G <sup>3</sup>	External Ground	-	-	-	-
8	n.c.		-	-	-	-	-
9	n.c.		-	-	-	-	-
10	STROBE_OUT	O <sup>3</sup>	Open drain	-	-	24.0 <sup>1</sup>	V
11	TRIGGER_IN (+)	I <sup>3</sup>	Optocoupler signal	3.3 <sup>2</sup>	-	24.0 <sup>2</sup>	V
12	TRIGGER_IN (-)	I <sup>3</sup>	Optocoupler ground	-	-	-	-

<sup>1</sup> max. 0.2A (ID) for open drain MOSFET!

<sup>2</sup> min. 3.5 mA driver strength required!

<sup>3</sup> G: Ground O: Output I: Input

The part number of this Hirose connector is HR10A10R-12P(73). To realize an I/O cable you need a Hirose connector HR10A-10P-12S(73).



## 3.1.1 TRIGGER\_IN

The *TRIGGER\_IN* line can be used to synchronize the start of the exposure time with external events. The [Trigger](#) section describes in detail how the image sensor's behavior can be controlled.

The current input signal can also be read directly through the [General Purpose Input](#) feature.

## 3.1.2 STROBE\_OUT

The *STROBE\_OUT* line's main usage is to indicate the integration time of the image sensor which allows flashes, strobes or other light sources to be synchronized with camera operation. The line's behavior can be controlled through the [Strobe](#) controls.

The output signal can also be directly controlled through the [General Purpose Output](#) feature.



## 4 Spectral Characteristics

### 4.1 IR-Cut Filter

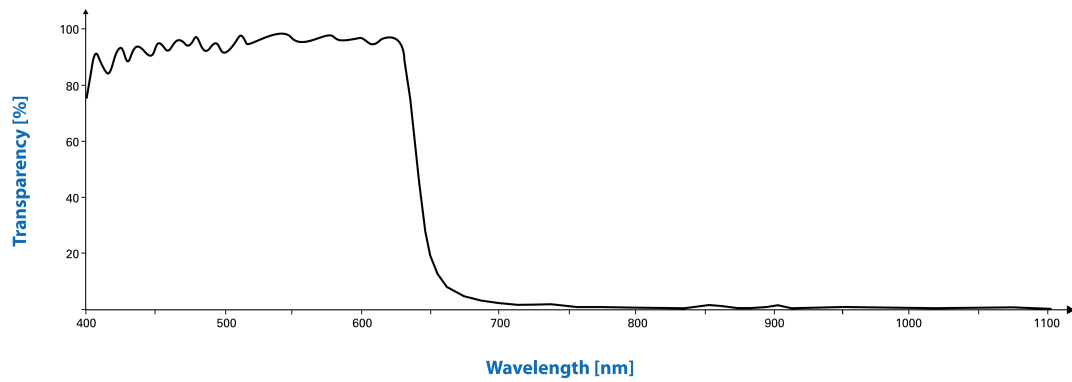

### 4.2 Spectral Sensitivity - P2000

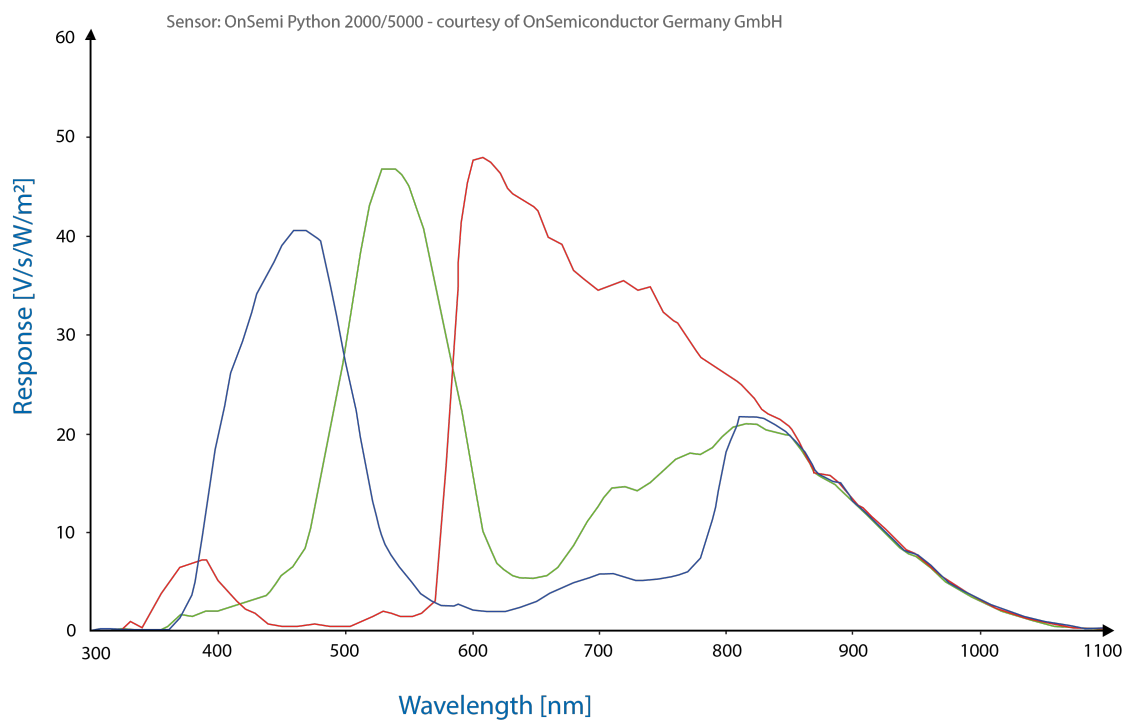



## 5 Camera Controls

This section describes the parameters available for the DFK 33UP2000 camera.

The actual name of the parameter depends on the driver technology used to access the camera. Parameter names are listed for the three most common ways to access the cameras:

- *USB3 Vision* (cross platform, via 3rd party driver)
- UVC/V4L2 (on Linux, via `uvccvideo`)
- *IC Imaging Control* (on Windows, via *Device Driver for The Imaging Source USB Cameras*)

### 5.1 Sensor Readout Control

#### 5.1.1 Pixel Format

The pixel format defines the data type of the pixels transmitted to the computer. The bits per pixel needed for a particular pixel format influence the required bandwidth.

The way the pixel format is controlled varies greatly between the driver technology used to access the camera:

- When using *USB3 Vision*, the pixel format is controlled through the `PixelFormatGenlCam` feature.
- When using the `uvccvideo` driver on Linux, the pixel format is defined by `video4linux2`.
- When using *IC Imaging Control*, the pixel format is part of the video format - a parameter which combines pixel format, resolution and readout mode. For more information, refer to the *IC Imaging Control* documentation sections on `VideoFormat` and `VideoFormatDesc`.

The DFK 33UP2000 color camera supports multiple pixel formats with variable bits-per-pixel settings. The names of the pixel formats and the way to select them depends on the driver used to control the camera. The following table contains a short overview of all possible formats followed by a more detailed description.

Pixel Format	Bits Per Pixel	USB3 Vision	UVC	TIS UVC Driver"
8-Bit Bayer (BG)	8	BayerBG8	BA81	RGB32, Y800
10-Bit Packed Bayer (BG)	10	BayerBG10p	BGAp	RGB64, Y16
YUV 4:1:1 (a)	12	YCbCr411_8		
YUV 4:1:1 (b)	12	YCbCr411_8_CbYYCrYY	Y411	Y411
8-Bit Monochrome	8	Mono8		



## 5.1.1.1 8-Bit Bayer Raw

This format transmits data using one byte for each pixel.

*USB3 Vision* drivers see this pixel format as one of the 8-bit bayer raw formats (BayerGR8, BayerRG8, BayerGB8, BayerBG8).

UVC drivers see it with the *FourCC* GRBG, RGGB, GBRG or BA81.

The *Device Driver for The Imaging Source USB Cameras* simplifies this variety of possible pixel formats, and offers two video formats instead: RGB32 and Y800. The RGB32 format results from the driver's automatic debayering of the raw image data, while the Y800 format contains the raw data which is reinterpreted as monochrome.

## 5.1.1.2 10-Bit Packed Bayer Raw

This format transmits data using 5 bytes for each group of 4 consecutive pixels.

*USB3 Vision* drivers see this pixel format as one of the 10-bit packed bayer raw formats (BayerGR10p, BayerRG10p, BayerGB10p, BayerBG10p).

UVC drivers see it with the *FourCC* GRAp, RGAp, GBAp or BGAp.

The *Device Driver for The Imaging Source USB Cameras* simplifies this variety of possible pixel formats, and offers two video formats instead: RGB64 and Y16. The RGB64 format results from the driver's automatic debayering of the raw image data, while the Y16 format contains the raw data which is reinterpreted as monochrome. Since the DFK 33UP2000 camera offers both 10-bit packed and 16-bit bayer raw pixel formats, the driver uses the 10-bit packed format when the RGB64 or Y16 video format is selected.

## 5.1.1.3 YUV 4:1:1

This format transmits an 8-bit luminance value for every pixel and a pair of chrominance values for every four pixels.

The two YUV 4:1:1 pixel formats only differ in their byte order.

The camera converts the raw pixel data from the sensor to YUV 4:2:2. Since YUV 4:2:2 averages to 1.5 bytes per pixel, the YUV 4:2:2 pixel format requires two 50% more bandwidth than the 8-bit raw format, thus reducing the maximum possible frame rate.

*USB3 Vision* drivers see this pixel format as YCbCr411\_8 and YCbCr411\_8\_CbYYCrYY.

UVC drivers see it with the *FourCC* Y411.

The *Device Driver for The Imaging Source USB Cameras* offers this pixel format as the Y411 video format.

## 5.1.1.4 8-Bit Monochrome

The camera generates the pixel data by debayering the raw pixel data and transmitting only the luminance information.



USB3 Vision drivers enumerate this pixel format as `Mono8`.

UVC drivers do not have access to this format.

## 5.1.2 Resolution

The DFK 33UP2000 allows the user to specify which rectangular region of the image sensor to read out during camera operation. The size of this rectangle determines the number of pixels that have to be transferred for each frame and has a significant influence on the required USB bandwidth.

Lowering the resolution also often allows the image sensor to operate at a higher frame rate. Changes in the vertical resolution have more effect on the maximum frame rate than changes in the horizontal direction.

The way the resolution is controlled varies greatly between the driver technology used to access the camera:

- When using *USB3 Vision*, the resolution is controlled through the GenICam features `Width` and `Height`.
- When using the `uvcdiag` on Linux, the resolution is selected from a list of fixed formats. Dynamic frame sizes are not available.
- When using *IC Imaging Control*, the resolution is part of the video format, a parameter that combines pixel format, resolution and readout mode. For more information, refer to the *IC Imaging Control* documentation sections on `VideoFormat` and `VideoFormatDesc`.

Parameter	Horizontal Resolution
Minimum	256
Maximum	1920
USB3 Vision: GenICam	<code>Width</code>

Parameter	Vertical Resolution
Minimum	16
Maximum	1200
USB3 Vision: GenICam	<code>Height</code>

## 5.1.3 Readout Modes

The DFK 33UP2000 camera offers different sensor readout modes.

By default, the camera outputs all pixels of the image sensor.

In *skipping* modes, the image sensor regularly skips a number of rows and/or columns during readout. The resulting output image is smaller but contains the same field of view than the image produced by default readout mode.



In *binning* modes, a number of neighboring pixels is merged into one output pixel during readout. The nature of this merge operation is sensor-specific, most sensors either add the pixel values or average them.

Generally, binning modes provide better image quality than skipping modes. However, skipping modes usually provide a higher maximum frame rate.

The way the readout modes are controlled depends greatly upon which driver technology is used to access the camera:

- When using *USB3 Vision*, the readout mode is controlled through the *GenICam* features `DecimationHorizontal`, `DecimationVertical`, `BinningHorizontal` and `BinningVertical`.
- Selecting readout modes is currently not supported through UVC in Linux.
- When using *IC Imaging Control*, the readout mode is part of the video format - a parameter that which combines pixel format, resolution and readout mode. For more information, refer to the *IC Imaging Control* documentation sections on `VideoFormat` and `VideoFormatDesc`.

The following readout modes are supported:

- Default
- Skipping 2X

## 5.1.4 Frame Rate

The frame rate is specified in frames per second and determines the camera's operating speed.

The way the frame rate is controlled depends greatly upon which driver technology is used to access the camera:

- When using *USB3 Vision*, the frame rate is controlled through the *GenICam* feature `AcquisitionFrameRate`.
- When using `uvcdm` on Linux, the frame rate is selected from a list of available frame rates.
- When using *IC Imaging Control*, the frame rate is selected from a list of available frame rates through APIs such as `Grabber::setFPS` or `ICImagingControl.DeviceFrameRate`.

The range of available frame rates depends on other camera settings such as pixel format, resolution and readout modes.

Parameter	Frame Rate
Minimum	Depending on Pixel Format, Resolution, and Readout Mode
Maximum	Depending on Pixel Format, Resolution, and Readout Mode
USB3 Vision: GenICam	<code>AcquisitionFrameRate</code>





The following tables show the maximum frame rate for some combinations of pixel format and resolution.

## 8-Bit Bayer Raw

Width	Height	Maximum Frame Rate
1920	1200	129
1920	1080	142
640	480	577

## 10-Bit Packed Bayer Raw

Width	Height	Maximum Frame Rate
1920	1200	128
1920	1080	142
640	480	577

## YUV 4:1:1 (a)

Width	Height	Maximum Frame Rate
1920	1200	108
1920	1080	120
640	480	577

## YUV 4:1:1 (b)

Width	Height	Maximum Frame Rate
1920	1200	108
1920	1080	120
640	480	577

## 8-Bit Monochrome

Width	Height	Maximum Frame Rate
1920	1200	129
1920	1080	142
640	480	577



## 5.1.5 Partial Scan Offset

If the selected resolution is smaller than the sensor size, the part of the sensor that is actually read out can be specified by the *Partial Scan Offset X* and *Partial Scan Offset Y* parameters. By default, the camera automatically positions the offsets so that the center of the sensor is used.

Parameter	Partial Scan Offset X
Minimum	0
Maximum	1664
USB3 Vision: GenICam	OffsetX
UVC	ROI Offset X
VCD Property	VCDID_PartialScanOffset \VCDElement_PartialScanOffsetX

Parameter	Partial Scan Offset Y
Minimum	0
Maximum	1184
USB3 Vision: GenICam	OffsetY
UVC	ROI Offset Y
VCD Property	VCDID_PartialScanOffset \VCDElement_PartialScanOffsetY

If *Partial Scan Offset X* or *Partial Scan Offset Y* is configured to a value that would be invalid with the current setting of [Resolution](#) setting, the camera uses the maximum possible value.

Parameter	Partial Scan Auto Center
On	Automatically configure Partial Scan Offset X/Y so that the center area of the sensor is read out
True	
Off	Control Partial Scan Offset X/Y manually
False	
USB3 Vision: GenICam	OffsetAutoCenter
UVC	ROI Auto Center
VCD Property	VCDID_PartialScanOffset \VCDElement_PartialScanAutoCenter



## 5.2 Image Sensor Control

### 5.2.1 Exposure Time

The *Exposure Time* parameter defines the time the camera opens its (electronic) shutter when it is taking an image.

Parameter	Exposure Time
Minimum	50 $\mu$ s
Maximum	10 s
Default	auto
USB3 Vision: GenICam	ExposureTime
UVC	Exposure Time (us)
VCD Property	VCDID_Exposure\VCDElement_Value

### 5.2.2 Gain

The *Gain* parameter defines the amplification that is applied to the image at sensor level.

Parameter	Gain
Minimum	0 dB
Maximum	32 dB
Default	auto
USB3 Vision: GenICam	Gain
UVC	Gain (db/100)
VCD Property	VCDID_Gain\VCDElement_Value

## 5.3 Automatic Exposure and Gain Control

The DFK 33UP2000 camera can automatically control gain and exposure time. These automatic functions are enabled by default.

In order to optimize image parameters, a region of interest can be specified for automatic functions which enables fine-grained control over the image area for that the image parameters are optimized. A selection of pre-defined area presets is available, but the user can also specify the coordinates of a custom rectangle.

In certain situations, it is desirable to limit the range of the auto-controlled parameters. For example, one might want to avoid high gain settings in order to keep noise levels low. Other applications require limiting the maximum exposure time so that



movements do not get blurred. Therefore, the ranges of the gain and exposure parameter can be limited.

If both auto exposure and auto gain are active, the camera tries to lower the gain value in order to reduce noise and improve the image quality.

### 5.3.1 Auto Exposure

Parameter	Auto Exposure
Continuous	Enable Auto Exposure
True	
Off	Disable Auto Exposure
False	
USB3 Vision: GenICam	ExposureAuto
UVC	Auto Shutter
VCD Property	VCDID_Exposure\VCDElement_Auto

### 5.3.2 Auto Gain

Parameter	Auto Gain
Continuous	Enable Auto Gain
True	
Off	Disable Auto Gain
False	
USB3 Vision: GenICam	GainAuto
UVC	Auto Gain
VCD Property	VCDID_Gain\VCDElement_Auto

### 5.3.3 Auto Reference Value

The *Auto Reference Value* parameter specifies the target brightness for both auto exposure and auto gain.



Parameter	Auto Reference Value
Minimum	0
Maximum	255
Default	128
USB3 Vision: GenICam	ExposureAutoReference
UVC	ExposureAutoReference
VCD Property	VCDID_Exposure\VCDElement_AutoReference

### 5.3.4 Highlight Reduction

Enabling *Highlight Reduction* lets the auto exposure and auto gain functions reduce overexposed areas in the output image. This feature is particularly useful when using 10/12/16-bit output images and a tone mapping algorithm in post-processing when using higher bit depths as the dark areas still contain a lot of useful information.

Parameter	Highlight Reduction
True	Try to reduce overexposed areas
False	Ignore overexposed areas and focus on matching the image brightness to the selected <a href="#">Auto Reference Value</a> .
USB3 Vision: GenICam	ExposureAutoHighlightReduction
UVC	Highlight Reduction
VCD Property	VCDID_HighlightReduction\VCDElement_Value

### 5.3.5 Auto Exposure Limits

The *Auto Exposure Lower Limit* parameter determines the minimum possible value that can be set by the auto exposure algorithm.

Parameter	Auto Exposure Lower Limit
Minimum	50 $\mu$ s
Maximum	1 s
USB3 Vision: GenICam	ExposureAutoLowerLimit
UVC	Exposure Auto Lower Limit

The *Auto Exposure Upper Limit* parameter determines the maximum possible value that can be set by the auto exposure algorithm.



Parameter	Auto Exposure Upper Limit
Minimum	50 $\mu$ s
Maximum	1 s
USB3 Vision: GenICam	ExposureAutoUpperLimit
UVC	Exposure Auto Upper Limit
VCD Property	VCDID_Exposure\VCDElement_AutoMaxValue

If the *Auto Exposure Upper Limit Auto* parameter is enabled, the value of *Auto Exposure Upper Limit* is automatically kept at the maximum possible value for the current frame rate.

Parameter	Auto Exposure Upper Limit Auto
On	Select <i>Auto Exposure Upper Limit</i> automatically
Off	Let the user control <i>Auto Exposure Upper Limit</i>
USB3 Vision: GenICam	ExposureAutoUpperLimitAuto
UVC	Exposure Auto Upper Limit Auto
VCD Property	VCDID_Exposure\VCDElement_AutoMaxValueAuto

### 5.3.6 Auto Gain Limits

The *Auto Gain Lower Limit* parameter determines the minimum possible value that can be set by the auto gain algorithm.

Parameter	Auto Gain Lower Limit
Minimum	0 dB
Maximum	32 dB
USB3 Vision: GenICam	GainAutoLowerLimit
UVC	Gain Auto Lower Limit

The *Auto Gain Upper Limit* parameter determines the maximum possible value that can be set by the auto gain algorithm.



Parameter	Auto Gain Upper Limit
Minimum	0 dB
Maximum	32 dB
USB3 Vision: GenICam	GainAutoUpperLimit
UVC	Gain Auto Upper Limit

## 5.4 Trigger

The trigger mode can be used to take images at very specific points in time which are specified by an electrical signal connected to the [TRIGGER\\_IN](#) pin of the I/O connector of the camera.

### 5.4.1 Trigger Mode

The *Trigger Mode* parameter enables the trigger mode.

Parameter	Trigger Mode
On	Enable Trigger Mode
True	
Off	Disable Trigger Mode
False	
USB3 Vision: GenICam	TriggerMode
UVC	Trigger Mode
VCD Property	VCDID_Trigger\VCDElement_Value

### 5.4.2 Trigger Polarity

The *Trigger Polarity* parameter controls whether a trigger event is accepted on the rising or falling edge of the signal connected to the TRIGGER\_IN line.

Parameter	Trigger Polarity
RisingEdge	Accept rising edge as trigger signal
True	
FallingEdge	Accept falling edge as trigger signal
False	
USB3 Vision: GenICam	TriggerActivation
UVC	Trigger Polarity
VCD Property	VCDID_Trigger\VCDElement_Polarity



## 5.4.3 Software Trigger

The *Software Trigger* function can be used to simulate a trigger pulse, in turn causing one image to be exposed and delivered to the host computer.

Parameter	Software Trigger
Execute	Simulate one trigger pulse
USB3 Vision: GenICam	TriggerSoftware
UVC	Software Trigger
VCD Property	VCDID_Trigger\VCDElement_SoftwareTrigger

## 5.4.4 Trigger Burst Count

The *Trigger Burst Count* parameter allows the camera to be configured to take more than one image per trigger pulse. By default, this parameter is set to 1 so that exactly one image is acquired. The images are taken as rapidly as possible given current settings (i.e. as limited by the current exposure time and frame rate settings).

Parameter	Trigger Burst Count
Minimum	1
Maximum	1000
Default	1
USB3 Vision: GenICam	AcquisitionBurstFrameCount
UVC	Trigger Burst Count
VCD Property	VCDID_Trigger\VCDElement_TriggerBurstCount

## 5.4.5 Trigger Source

The *Trigger Source* parameter allows the camera to be configured to only accept trigger signals from a specified source, e.g. only software trigger.

Parameter	Trigger Source
Any	Allow trigger signals from any source
Line1	Allow only hardware trigger
Software	Allow only software trigger
USB3 Vision: GenICam	TriggerSource





## 5.4.6 Trigger Overlap

The *Trigger Overlap* feature gives information on when a new trigger pulse is accepted in the trigger -> exposure -> readout sequence.

Parameter	Trigger Overlap
Off	The next trigger pulse is only accepted once the previous frame has been read out from the sensor
Readout	The next trigger pulse is accepted during readout as long as the remaining readout time is shorter than the exposure time
USB3 Vision: GenICam	TriggerOverlap
VCD Property	VCDID_Trigger\VCDElement_TriggerOverlap

## 5.5 Trigger Timing Parameters

The 33U series camera series offers several options for dealing with bad trigger signals. By using the *Debounce Time*, *Denoise Time* and *Mask Time* parameters, the camera can be configured to ignore pulses on its [TRIGGER\\_IN](#) line under certain conditions.

Useful values for these parameters are application-specific. They depend on the expected trigger frequency, the exposure time and assumptions about the input signal quality.

The default values for all these parameters is 0  $\mu$ s, assuming perfect signal quality.

### 5.5.1 Trigger Delay

The *Trigger Delay* parameter specifies a time for which the camera waits between receiving a trigger signal and starting the exposure of an image. Simulated trigger pulses generated through the *Software Trigger* function are not delayed by this parameter.

Parameter	Trigger Delay
Minimum	0 s
Maximum	1 s
Default	0 s
USB3 Vision: GenICam	TriggerDelay
UVC	Trigger Delay
VCD Property	VCDID_Trigger\VCDElement_TriggerDelay



## 5.5.2 Trigger Debounce Time

The *Trigger Debounce Time* parameter specifies the time for which the trigger input has to be low in order for the next trigger signal to be accepted.

Parameter	Trigger Debounce Time
Minimum	0 s
Maximum	1 s
Default	0 s
USB3 Vision: GenICam	TriggerDebouncer
UVC	Trigger Debounce Time (us)
VCD Property	VCDID_Trigger\VCDElement_TriggerDebouncer

## 5.5.3 Trigger Mask Time

The *Trigger Mask Time* parameter specifies the time for which trigger pulses are ignored after accepting a trigger signal.

Parameter	Trigger Mask Time
Minimum	0 s
Maximum	1 s
Default	0 s
USB3 Vision: GenICam	TriggerMask
UVC	Trigger Mask Time (us)
VCD Property	VCDID_Trigger\VCDElement_TriggerMask

## 5.5.4 Trigger Noise Suppression Time

The *Trigger Noise Suppression Time* parameter specifies the time for which trigger input has to be active in order to be accepted as a trigger signal.



Parameter	Trigger Noise Suppression Time
Minimum	0 s
Maximum	1 s
Default	0 s
USB3 Vision: GenICam	TriggerDenoise
UVC	Trigger Noise Suppression Time
VCD Property	VCDID_Trigger\VCDElement_TriggerDenoise

## 5.6 Digital I/O

The 33U series has one digital input and one digital output. The digital input can be used as a [Trigger](#) input, and its current status can be examined.

The digital output can be configured as a [Strobe](#) output to signal the exact moment when the image sensor is sensitive to light so that external light sources can be synchronized to its operation cycle.

### 5.6.1 General Purpose Input

The *General Purpose Input* parameter allows the current status of the [TRIGGER\\_IN](#) pin.

Parameter	General Purpose Input
True	TRIGGER_IN line status is low
1	
False	TRIGGER_IN line status is high
0	
USB3 Vision: GenICam	GPIIn
UVC	GPIN
VCD Property	VCDID_GPIO\VCDElement_GPIORead VCDID_GPIO\VCDElement_GPIOIn

### 5.6.2 General Purpose Output

The *General Purpose Output* parameter controls the status of the [STROBE\\_OUT](#) pin.



Parameter	General Purpose Output
True	Drive the STROBE_OUT line high
1	
False	Drive the STROBE_OUT line low
0	
USB3 Vision: GenICam	GPOut
UVC	GPOUT
VCD Property	VCDID_GPIO\VCDElement_GPIOWrite VCDID_GPIO\VCDElement_GPIOOut

## 5.7 Strobe

The strobe function controls the automatic generation of output pulses on the [STROBE\\_OUT](#) pin which is synchronized to the image sensor's exposure time.

### 5.7.1 Strobe Enable

The *Strobe Enable* parameter enables the automatic generation of strobe pulses.

Parameter	Strobe Enable
On	Strobe enabled
True	
Off	Strobe disabled
False	
USB3 Vision: GenICam	StrobeEnable
UVC	Strobe Enable
VCD Property	VCDID_Strobe\VCDElement_Value

### 5.7.2 Strobe Polarity

The *Strobe Polarity* parameter can be used to invert the strobe pulse output.



Parameter	Strobe Polarity
ActiveHigh	The STROBE_OUT pin is logically high during the exposure time
True	
ActiveLow	The STROBE_OUT pin is logically low during the exposure time
False	
USB3 Vision: GenICam	StrobePolarity
UVC	Strobe Polarity
VCD Property	VCDID_Strobe\VCDElement_StrobePolarity

### 5.7.3 Strobe Operation

The *Strobe Operation* parameter specifies how the length of the strobe pulses are controlled.

Parameter	Strobe Operation
Exposure	Output pulse duration is equal to the current exposure time
True	
USB3 Vision: GenICam	StrobeOperation
UVC	Strobe Exposure
VCD Property	VCDID_Strobe\VCDElement_StrobeMode

## 5.8 White Balance

The DFK 33UP2000 color camera can perform white balance by digital multiplication of the appropriate raw pixel values.

### 5.8.1 Auto White Balance

DFK 33UP2000 can perform *Auto White Balance*. It can be enabled continuously, when changes in lighting conditions are expected. Under controlled lighting conditions, however, one-time white balance calibration is the recommended approach.

To perform one-time white balance calibration, place a reference white sheet in front of the camera, and set `BalanceWhiteAuto` to *Once*. The camera will then find the correct white balance settings for the current light conditions and keep them active until instructed otherwise.



Parameter	Auto White Balance
Continuous	Enable automatic white balance
True	
Once	Enable automatic white balance until the color channels have been balanced once
One Push	
Off	Disable automatic white balance
False	
USB3 Vision: GenICam	BalanceWhiteAuto
UVC	White Balance Component, Auto
VCD Property	VCDID_WhiteBalance\VCDElement_Auto VCDID_WhiteBalance\VCDElement_OnePush

## 5.8.2 White Balance Mode

The default auto white balance algorithm is *Gray World*. It is selected by setting the *White Balance Mode* accordingly. The *Gray World* algorithm operates under the assumption that the average color of a scene is near gray and adjusts the white balance coefficients so the average color of the resulting image is gray as well. In case this where assumption is wrong (e.g. the camera is pointing at a blue carpet), the auto white balance algorithm will select coefficients that do not result in a visually accurate image.

To avoid the problems posed by the *Gray World* algorithm, the *Temperature* mode can be used. This mode operates by trying to determine the color temperature of the light source.

Parameter	White Balance Mode
Gray World	Use the <i>Gray World</i> model
Temperature	Use the <i>Temperature</i> model
USB3 Vision: GenICam	BalanceWhiteMode
UVC	Whitebalance Mode
VCD Property	VCDID_WhiteBalance \VCDElement_WhiteBalanceMode

To assist the automatic white balance temperature detection, *White Balance Auto Preset* can be used to limit the range of valid color temperatures.



Parameter	White Balance Auto Preset
Any	Allow any color temperature
Auto Warm White	Limit color temperature to approximately 2500-4000 K
Auto Cool White	Limit color temperature to approximately 4000-5800 K
Auto Daylight	Limit color temperature to approximately 5700-7500 K
Auto Deep Shade	Limit color temperature to approximately 7500-10000 K
USB3 Vision: GenICam	BalanceWhiteAutoPreset
UVC	Whitebalance Auto Preset
VCD Property	VCDID_WhiteBalance \VCDElement_WhiteBalanceAutoPreset

### 5.8.3 Manual White Balance

If *Auto White Balance* is not enabled, the amplifiers for the red, green and blue channels can be controlled manually.

Parameter	White Balance Red
Minimum	0
Maximum	3.984375
Default	auto
USB3 Vision: GenICam	BalanceRatio[BalanceRatioSelector=Red]
UVC	White Balance Red Component
VCD Property	VCDID_WhiteBalance \VCDElement_WhiteBalanceRed

Parameter	White Balance Green
Minimum	0
Maximum	3.984375
Default	auto
USB3 Vision: GenICam	BalanceRatio[BalanceRatioSelector=Green]
UVC	White Balance Green Component
VCD Property	VCDID_WhiteBalance \VCDElement_WhiteBalanceGreen



Parameter	White Balance Blue
Minimum	0
Maximum	3.984375
Default	auto
USB3 Vision: GenICam	BalanceRatio[BalanceRatioSelector=Blue]
UVC	White Balance Blue Component
VCD Property	VCDID_WhiteBalance \VCDElement_WhiteBalanceBlue

If *White Balance Mode* is set to *Temperature*, the color temperature can be set directly. Additionally, a light source can be selected from a list of presets.

Parameter	White Balance Temperature
Minimum	2500 K
Maximum	10000 K
Default	auto
USB3 Vision: GenICam	BalanceWhiteTemperature
UVC	White Balance Temperature
VCD Property	VCDID_WhiteBalance \VCDElement_WhiteBalanceTemperature





Parameter	White Balance Temperature Preset
Sodium-Vapor Lamp	2500 K
Warm Light	2700 K
Halogen Light	3000 K
Neutral White	3500 K
Cool White Fluorescent Light	4000 K
Cool White/Daylight (CFL)	5000 K
Daylight	6000 K
Cool White LED	7500 K
Blue Sky	10000 K
USB3 Vision: GenICam	BalanceWhiteTemperaturePreset
UVC	Whitebalance Temperature Preset
VCD Property	VCDID_WhiteBalance \VCDElement_TemperaturePreset

## 5.9 Image Processing

### 5.9.1 Gamma

The 33U series cameras can perform gamma correction on the image data. If the pixel format of a color camera is set a YUV mode, gamma correction is applied to the Y channel. In bayer raw and RGB24 modes, all color channels are subject to the same gamma correction.

Parameter	Gamma
Minimum	0.01
Maximum	5.0
Default	1.0
USB3 Vision: GenICam	Gamma
UVC	Gamma
VCD Property	VCDID_Gamma\VCDElement_Value



## 5.9.2 Lookup Table

The 33U series allows the user to specify a lookup table (LUT) that can transform pixel values. This lookup table can be used to perform tasks like histogram equalization inside the camera.

If the pixel format of a color camera is set to one of the YUV modes, the lookup table is applied only to the Y channel. In bayer raw and RGB24 modes, all color channels are subject to the same lookup operation.

The lookup table has 257 16-bit entries. The upper 8 bits of the image data are used to select the appropriate entry in the lookup table, while the remaining bits are used to interpolate between the selected entry and one of its neighbors.

The *LUT Enable* feature enables the lookup table.

Parameter	LUT Enable
True	Enable lookup table operation
False	Disable lookup table operation
USB3 Vision: GenICam	LUTEnable

The lookup table values can be programmed using the *LUT Index* and *LUT Value* features.

Parameter	LUT Index
Minimum	0
Maximum	256
USB3 Vision: GenICam	LUTIndex

Parameter	LUT Value
Minimum	0
Maximum	65535
USB3 Vision: GenICam	LUTValue

The whole lookup table can be quickly reprogrammed through the *LUT Value All* feature.

Parameter	LUT Value All
Value	1028 bytes of memory containing 257 LUT entries. Each 16-bit LUT entry is aligned on a 32-bit boundary
USB3 Vision: GenICam	LUTValueAll



**Important:** Since gamma correction is implemented using the same hardware as the lookup table, gamma correction is disabled when the lookup table is enabled.

## 5.10 Color Processing

The DFK 33UP2000 color camera allows color adjustments with the *Hue* and *Saturation* parameters. These adjustments work with all output pixel formats.

**Important:** When a bayer raw pixel format is selected, *Hue* and *Saturation* still work. However, when at least one of them is enabled (set to non-default value), the resulting image is slightly blurred because of the way these parameters are implemented internally.

### 5.10.1 Hue

The *Hue* parameter controls the color angle of the output image.

Parameter	Hue
Minimum	-180
Maximum	180
Default	0
USB3 Vision: GenICam	Hue
UVC	Hue
VCD Property	VCDID_Hue\VCDElement_Value

### 5.10.2 Saturation

The *Saturation* parameter controls the color saturation of the output image.

Parameter	Saturation
Minimum	0
Maximum	255
Default	64
USB3 Vision: GenICam	Saturation
UVC	Saturation
VCD Property	VCDID_Saturation\VCDElement_Value



## 5.11 Region of Interest for Auto Functions

The 33U series cameras allow for the setting of a region of interest that is used while controlling the [Auto Exposure](#), [Auto Gain](#) and [Auto White Balance](#) functions.

### 5.11.1 Auto Functions ROI Enable

The *Auto Functions ROI Enable* parameter allows for the use of a region of interest for auto functions.

Parameter	Auto Functions ROI Enable
True	Auto functions only take a specified part of the image into account
False	Auto functions look at the whole image
USB3 Vision: GenICam	AutoFunctionsROIEnable
UVC	Auto Functions ROI Enable
VCD Property	VCDID_AutoRoi\VCDElement_Value

### 5.11.2 Auto Functions ROI Preset

The *Auto Functions ROI Preset* parameter lets the user select from a list of ROI presets.

Parameter	Auto Functions ROI Preset
Full Sensor	Select the full output image
Center 50%	Select a rectangular area in the center of the output image
Center 25%	Select a small rectangular area in the center of the output image
Bottom Half	Select the bottom half of the output image
Top Half	Select the top half of the output image
Custom Rectangle	Select a custom rectangle for fine-grained control
USB3 Vision: GenICam	AutoFunctionsROI_Preset
UVC	Auto Functions ROI Preset
VCD Property	VCDID_AutoRoi\VCDElement_AutoRoiPreset



### 5.11.3 Auto Functions ROI Custom Rectangle

When *Auto Functions ROI Preset* is set to *Custom Rectangle*, the user can manually set the position and size of the region of interest. The coordinates are relative to the origin of the current video format as specified by [Partial Scan Offset](#).

Parameter	Auto Functions ROI Left
Minimum	0
Maximum	2576
USB3 Vision: GenICam	AutoFunctionsROILeft
UVC	Auto Functions ROI Left
VCD Property	VCDID_AutoRoi \VCDElement_AutoRoiLeftRelative

Parameter	Auto Functions ROI Top
Minimum	0
Maximum	2032
USB3 Vision: GenICam	AutoFunctionsROI Top
UVC	Auto Functions ROI Top
VCD Property	VCDID_AutoRoi \VCDElement_AutoRoiTopRelative

Parameter	Auto Functions ROI Width
Minimum	16
Maximum	2592
USB3 Vision: GenICam	AutoFunctionsROIWidth
UVC	Auto Functions ROI Width
VCD Property	VCDID_AutoRoi \VCDElement_AutoRoiWidthRelative



Parameter	Auto Functions ROI Height
Minimum	16
Maximum	2048
USB3 Vision: GenICam	AutoFunctionsROIHeight
UVC	Auto Functions ROI Height
VCD Property	VCDID_AutoRoi \VCDElement_AutoRoiHeightRelative

## 5.12 User Sets

The 33U series cameras can store their complete configuration into built-in non-volatile memory. The camera configuration can be saved into and restored from one of two available memory slots upon user's request. Additionally, the camera can be configured to load one of the user's camera configurations at startup.

### 5.12.1 User Set Selector

The *User Set Selector* parameter selects the memory slot on which consecutive load and save commands are executed.

Parameter	User Set Selector
UserSet1	First of the two memory slots for user configurations
UserSet2	Second of the two memory slots for user configurations
Default	A special memory slot that always contains the camera's factory default configuration. It cannot be overwritten
USB3 Vision: GenICam	UserSetSelector

### 5.12.2 Load User Set

By using the *Load User Set* command, the user can restore the camera configuration from the memory slot selected by *User Set Selector*.

Parameter	Load User Set
Execute	Restore the camera configuration from the memory slot specified by <i>User Set Selector</i>
USB3 Vision: GenICam	UserSetLoad



## 5.12.3 Save User Set

By using the *Save User Set* command, the user can save the camera configuration into the memory slot selected by *User Set Selector*.

Parameter	Save User Set
Execute	Save the current camera configuration into the memory slot specified by <i>User Set Selector</i>
USB3 Vision: GenICam	UserSetSave

## 5.12.4 Default User Set

The *Default User Set* parameter controls the camera's startup behavior. It selects which memory slot is used for device initialization when the camera is powered up.

Parameter	Default User Set
UserSet1	Load configuration from the first memory slot
UserSet2	Load configuration from the second memory slot
Default	Load factory default configuration
USB3 Vision: GenICam	UserSetDefault



## 6 Revision History

Date	Version	Description
2018/04/19		Initial release of this document





## DFK 33UP2000 Technical Reference Manual

All product and company names in this document may be trademarks and tradenames of their respective owners and are hereby acknowledged.

The Imaging Source Europe GmbH cannot and does not take any responsibility or liability for any information contained in this document. The source code presented in this document is exclusively used for didactic purposes. The Imaging Source does not assume any kind of warranty expressed or implied, resulting from the use of the content of this document or the source code.

The Imaging Source Company reserves the right to make changes in specifications, function or design at any time and without prior notice.

Last update: May 2018

© 2018 The Imaging Source

All rights reserved. Reprint, also in parts, only allowed with permission of The Imaging Source Europe GmbH.

All weights and dimensions are approximate. Unless otherwise specified, the lenses shown in the context of cameras are not shipped with these cameras.

### **Headquarters:**

*The Imaging Source Europe GmbH  
Überseetor 18, D-28217 Bremen, Germany  
Phone: +49 421 33591-0*

### **North & South America:**

*The Imaging Source, LLC  
6926 Shannon Willow Rd, S 400, Charlotte, NC 28226, USA  
Phone: +1 704-370-0110*

### **Asia Pacific:**

*The Imaging Source Asia Co., Ltd.  
2F., No.8, Xinhu 1st Road  
Taipei City 114, Neihu District, Taiwan  
Phone: +886 2-2792-3153*

[www.theimagingsource.com](http://www.theimagingsource.com)