

品番	品名	材料	個数	記事
----	----	----	----	----

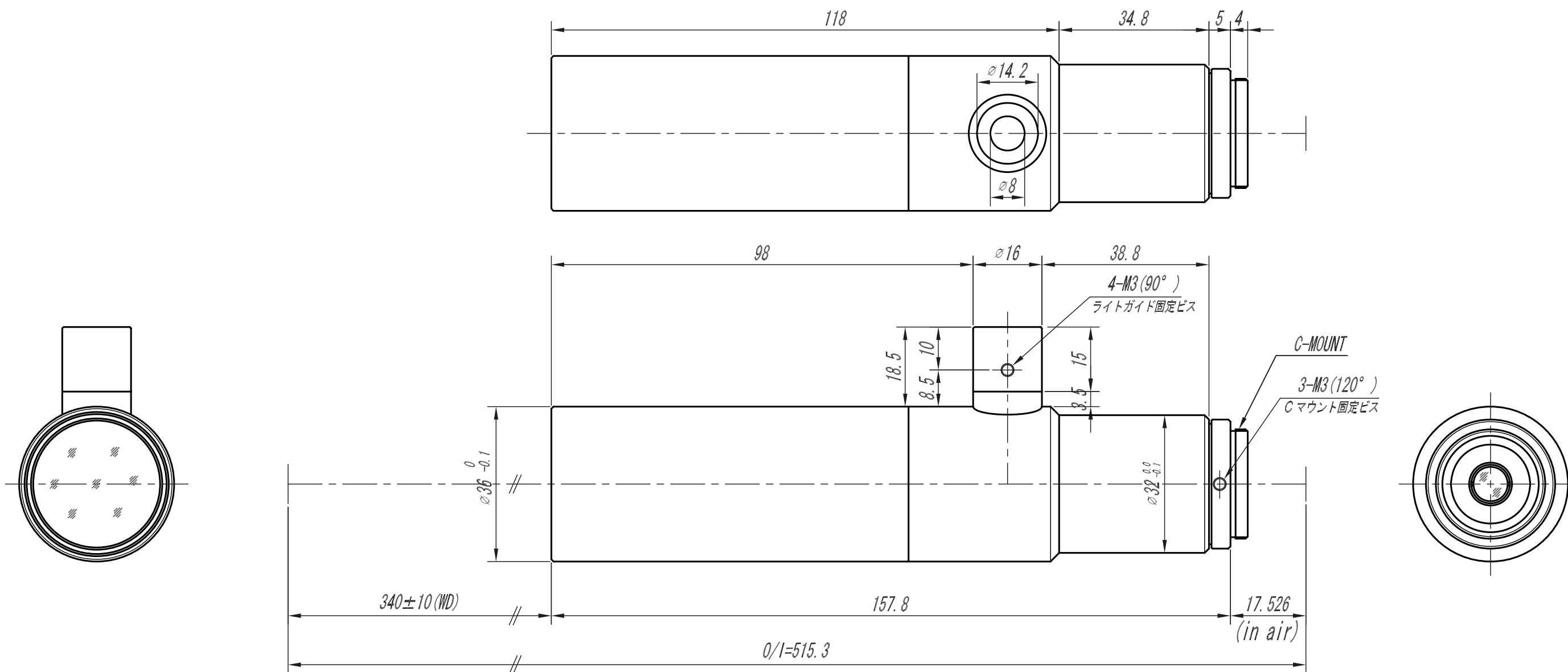

△				APPROVED	CHECKED	MATERIAL 材料	FINISH/ROUGHNESS 仕上程度	HEAT TREATMENT 熱処理	SURFACE TREATMENT 表面処理	QUANTITY 個数
△				J. A.	T. A.					
△				DESIGNED	DRAWN	OVER 250 UP TO 1000 ±0.3 ±0.5 ±1.0 ±0.2	UNIT (mm)	ANGLE 角度	METHOD 図法	REMARK 適用 (機種名)
△				T. T.	T. M.	OVER 63 UP TO 250 ±0.2 ±0.3 ±0.6 ±0.15	SCALE	1 / 1	NAME	VS-TC07-340C0
△						OVER 16 UP TO 63 ±0.1 ±0.2 ±0.4 ±0.1	DATE	'06.01.12	DRAW NO.	ODTC0293A1
	DATE	EXCH NO.	REVISION 変更記事			TOLERANCES A B C S				